

Valid Positives as function of False Positives

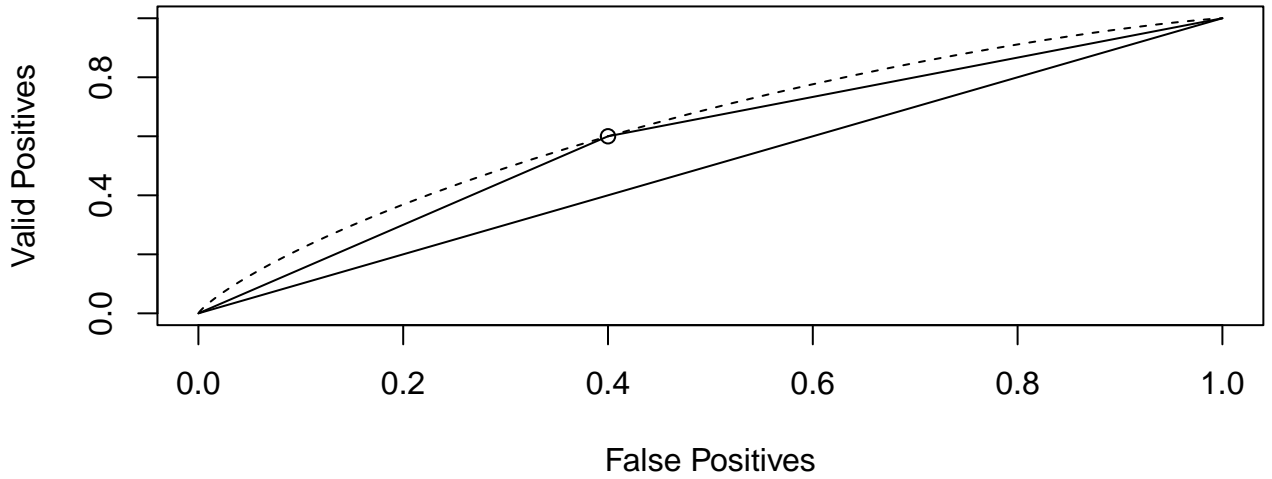

Decision Theory

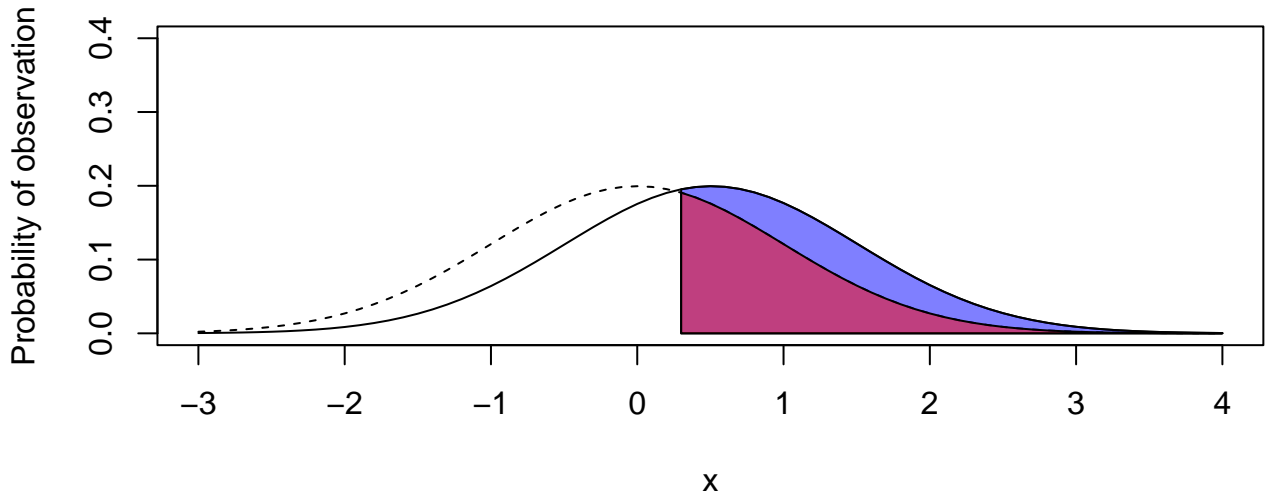

Valid Positives as function of False Positives

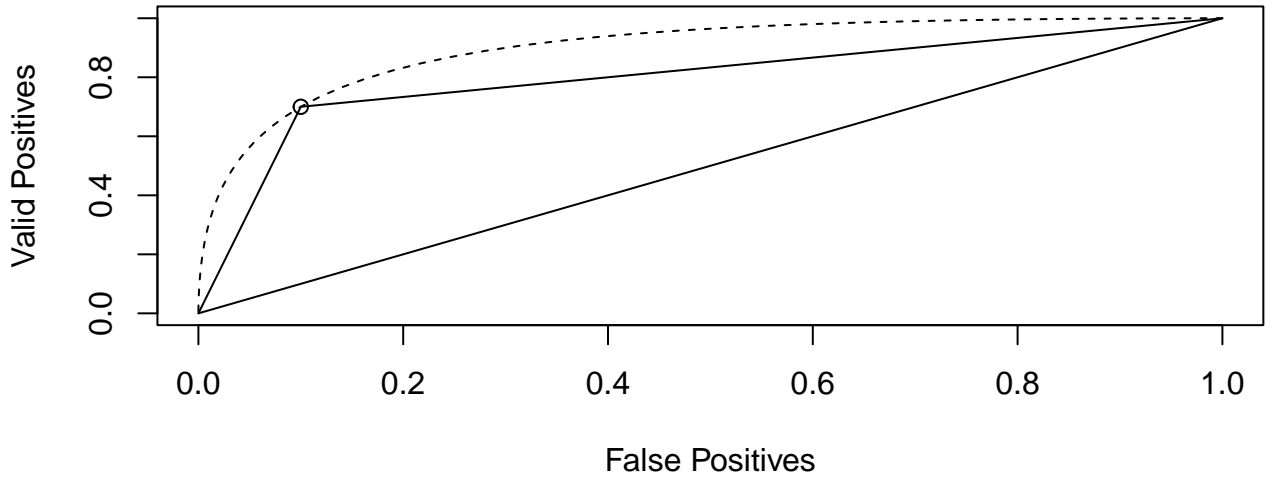

Decision Theory

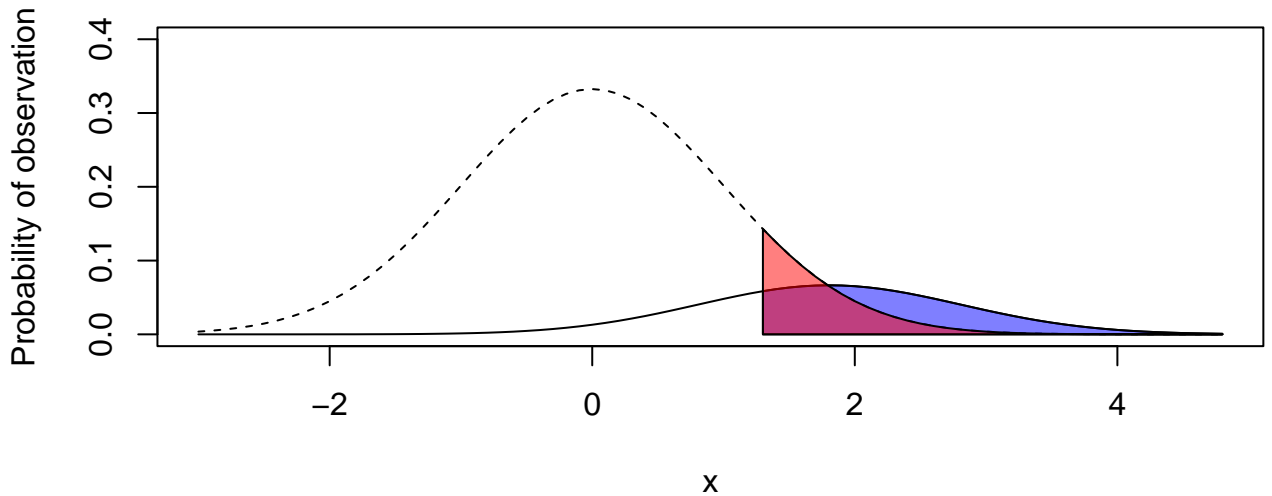

Valid Positives as function of False Positives

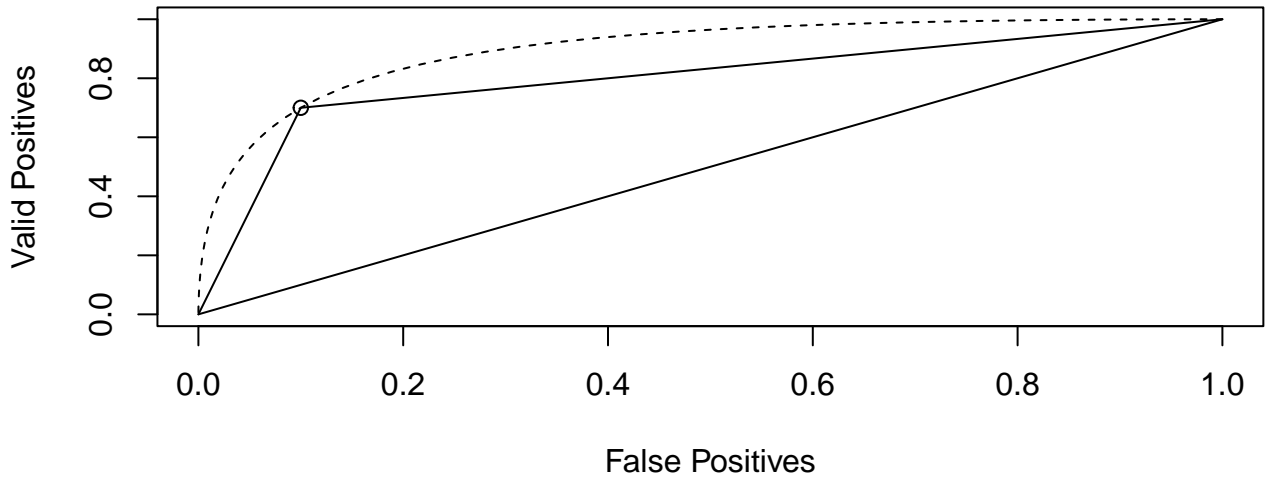

Decision Theory

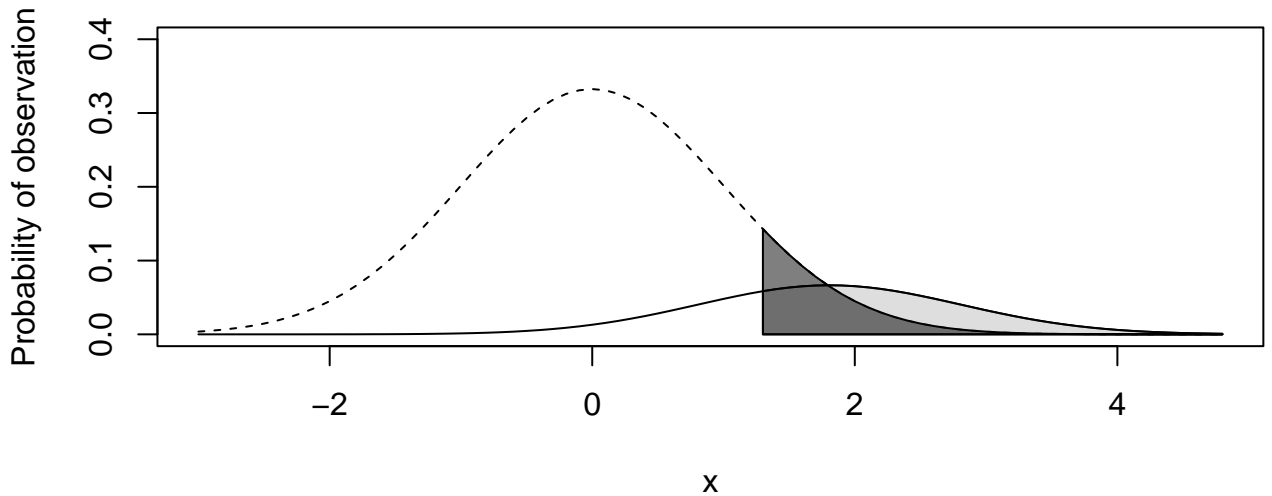

Valid Positives as function of False Positives

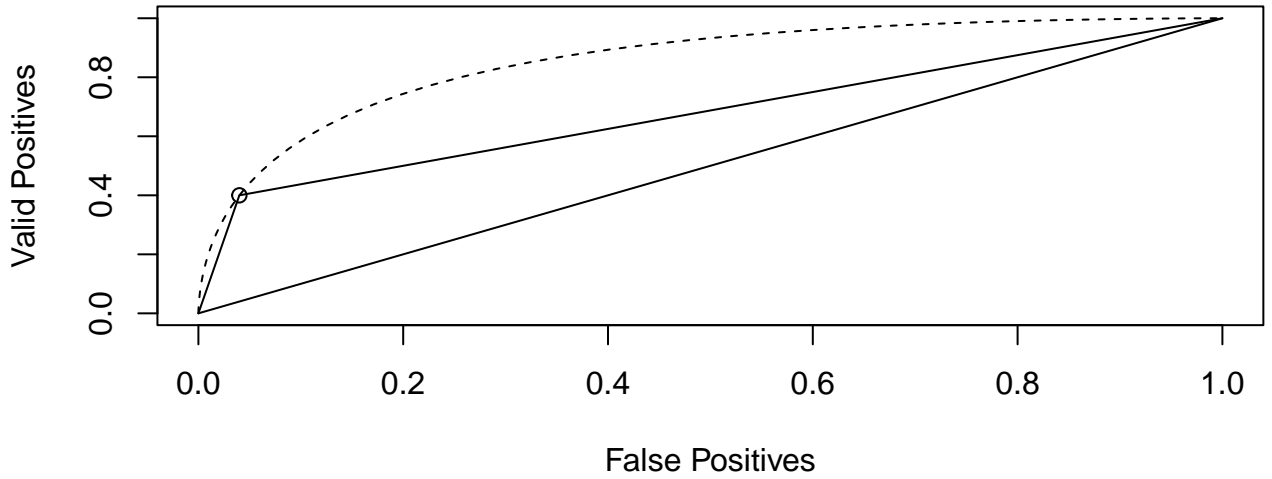

help("AUC")

Decision Theory

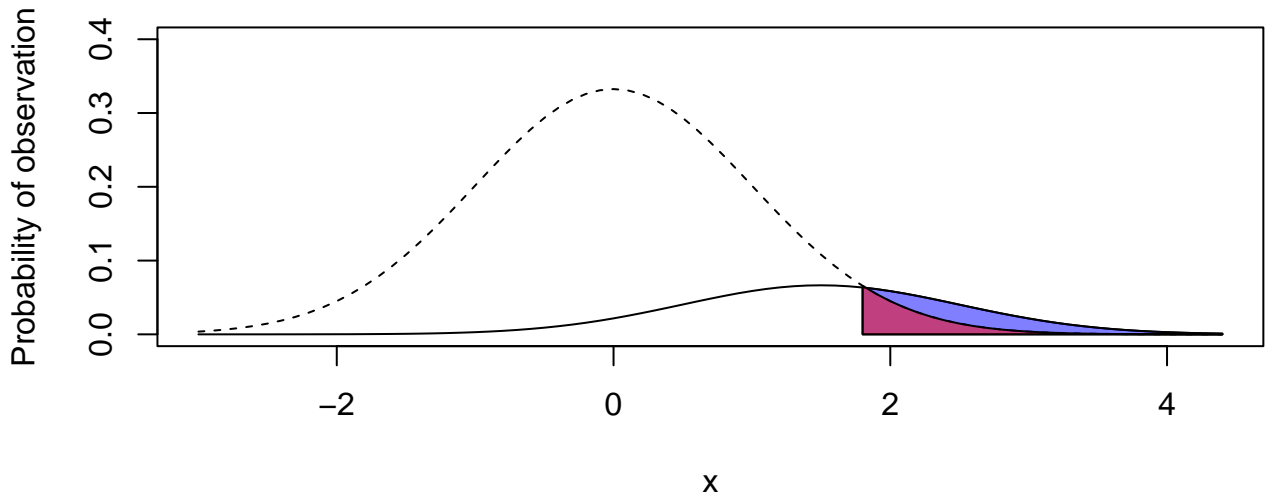

Valid Positives as function of False Positives

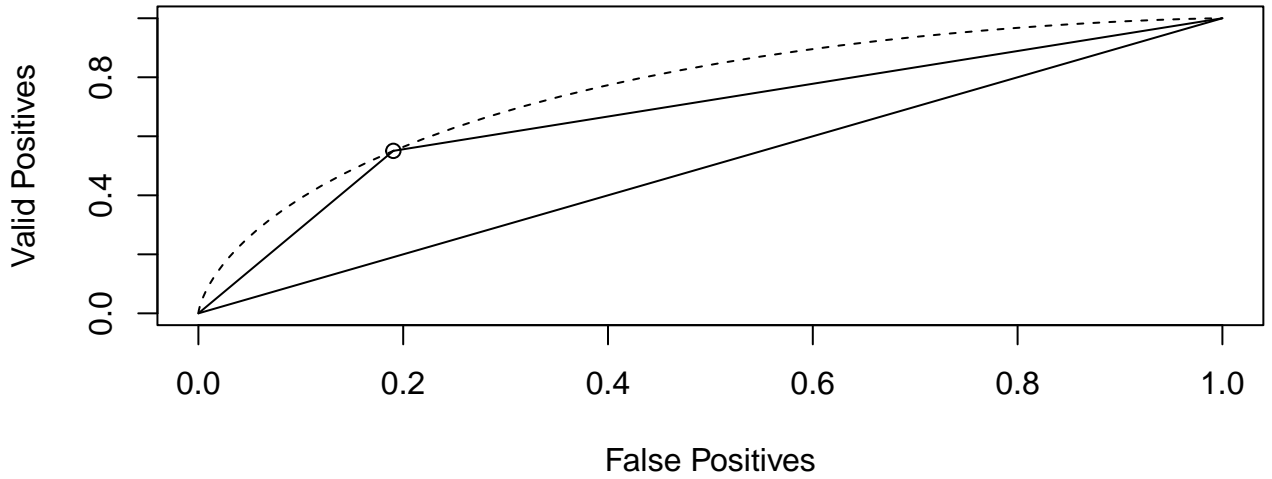

help("AUC")

Decision Theory

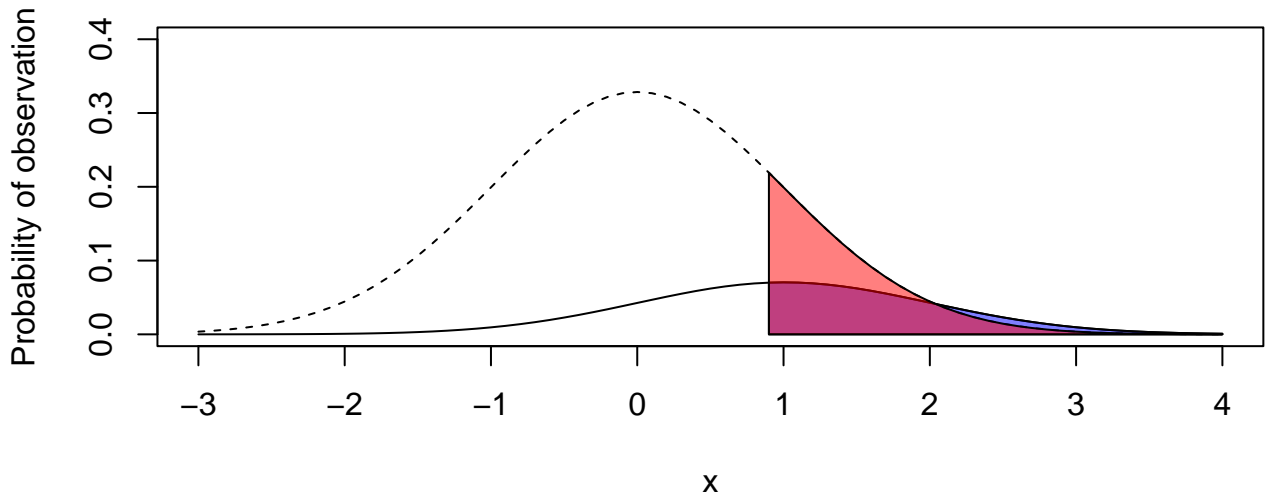

Valid Positives as function of False Positives

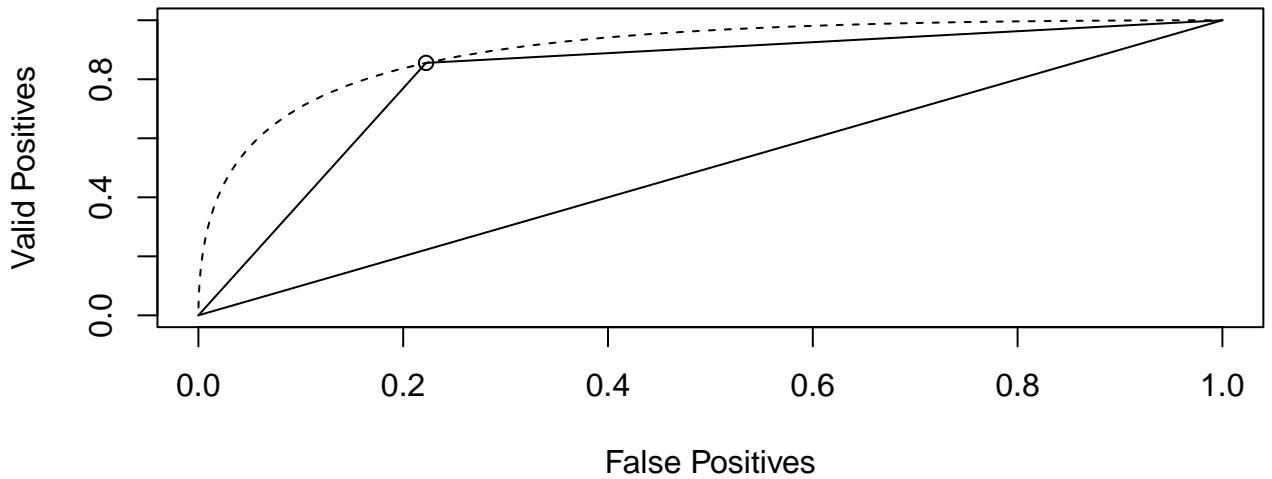

help("AUC")

Decision Theory

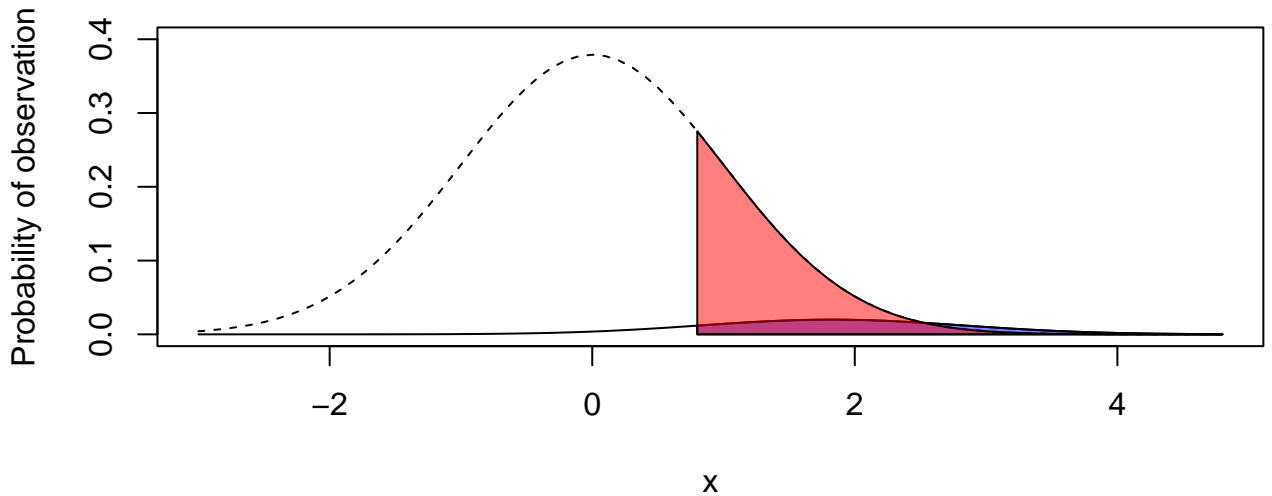

Moderated (mean centered)

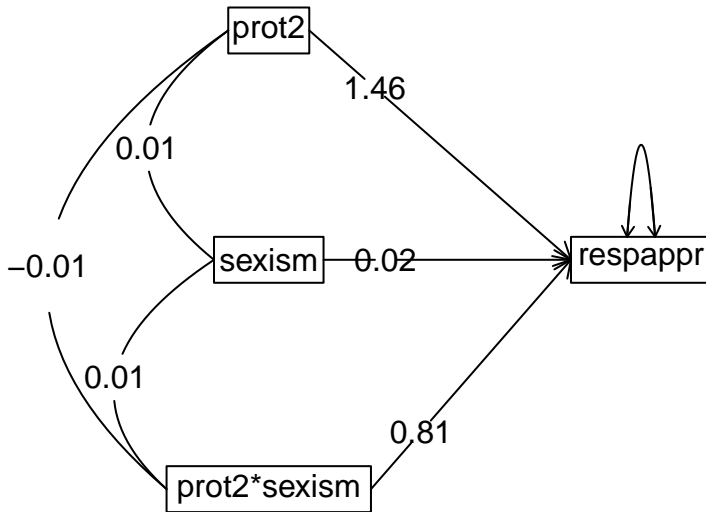

Moderated (don't center)

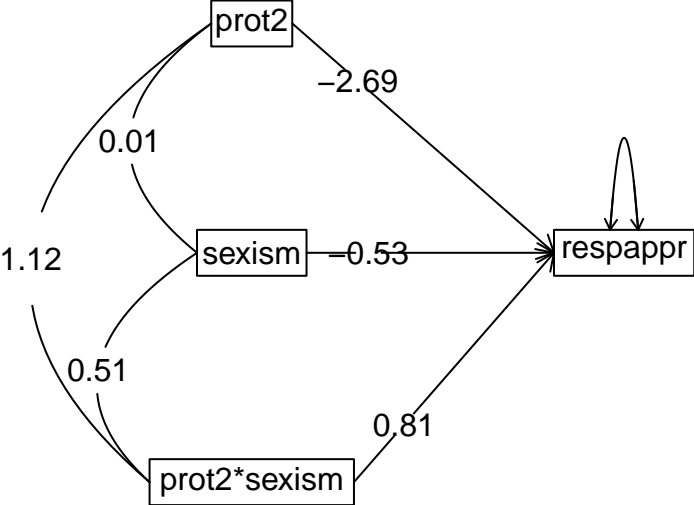

Response to sexism varies as type of protest

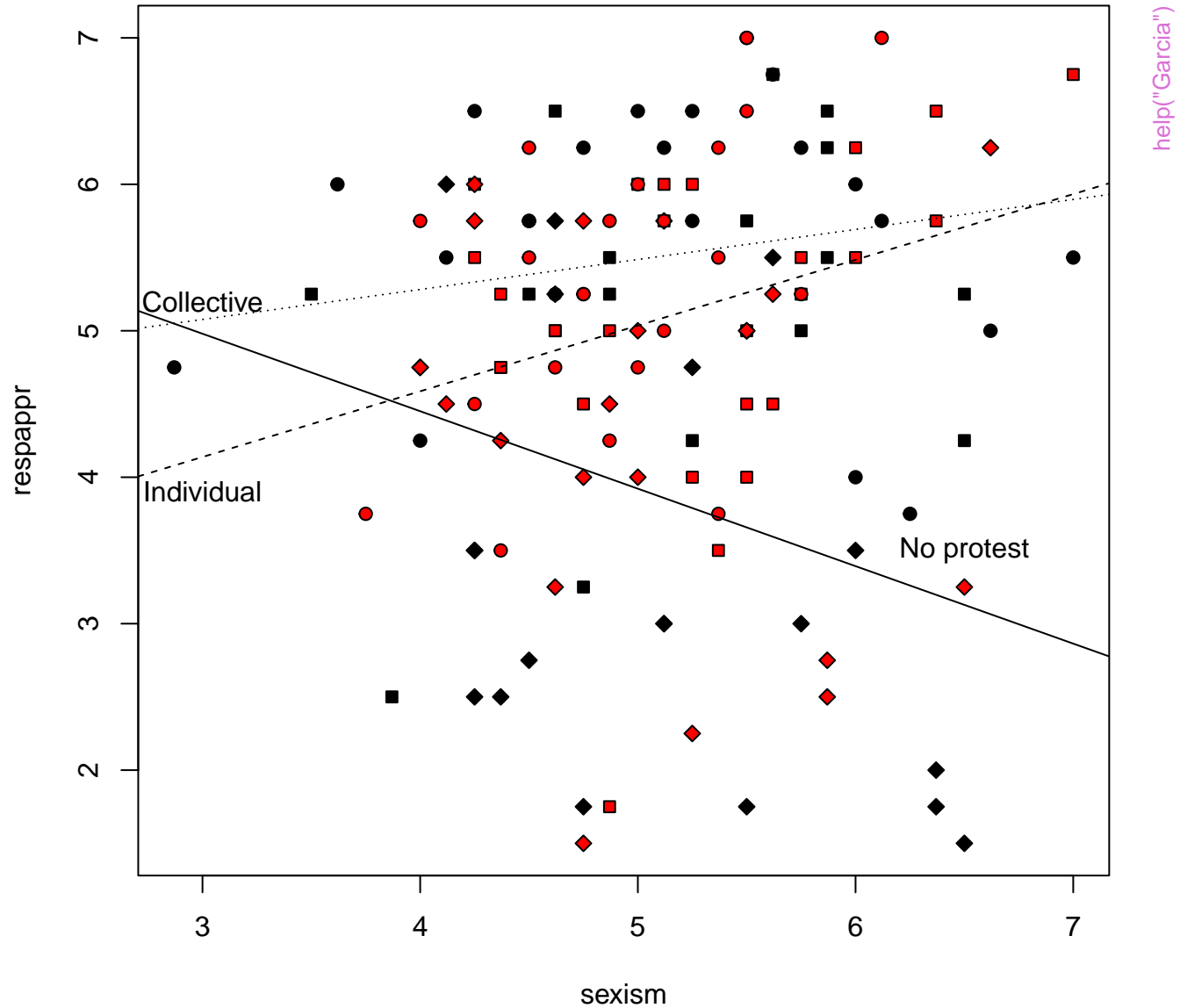

Moderated mediation (mean centered)

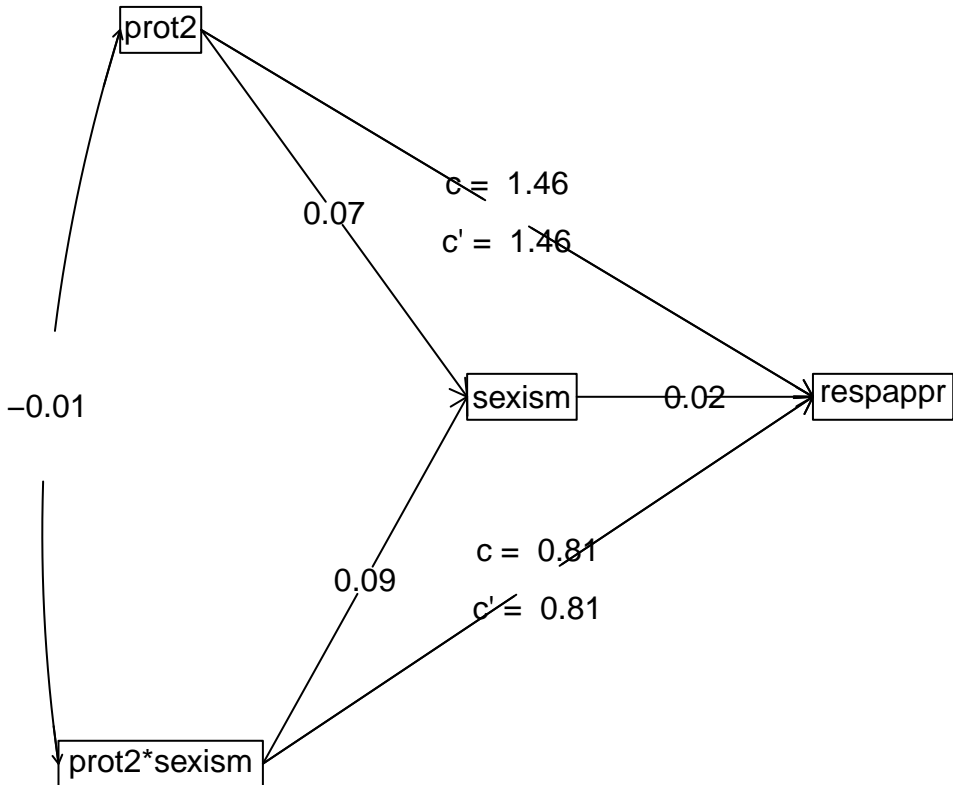

Moderated mediation (not centered)

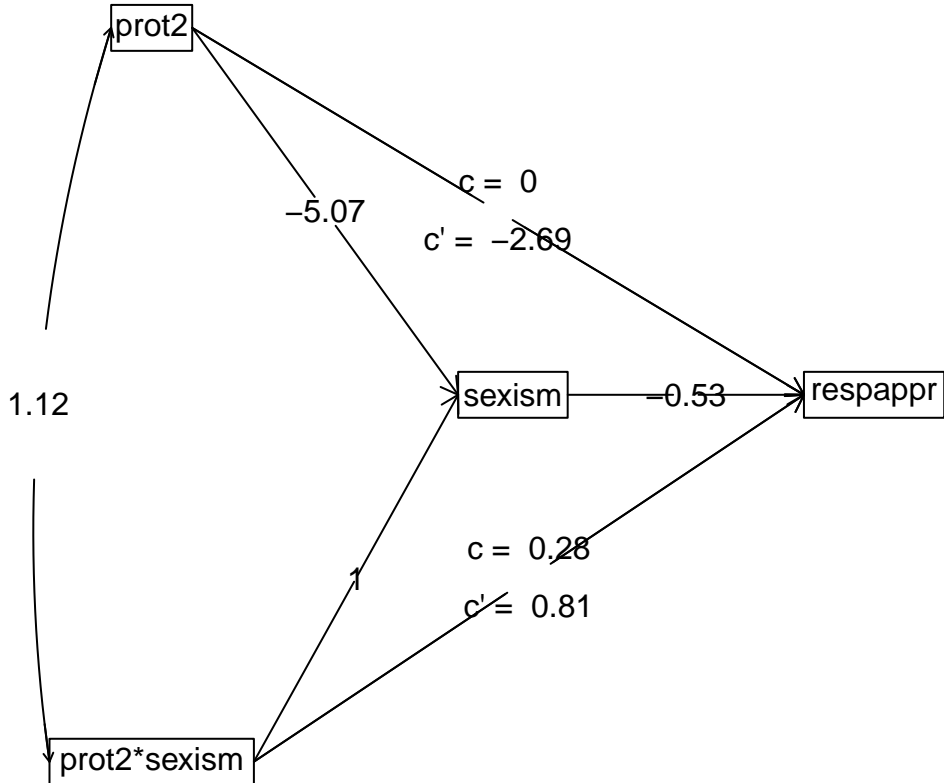

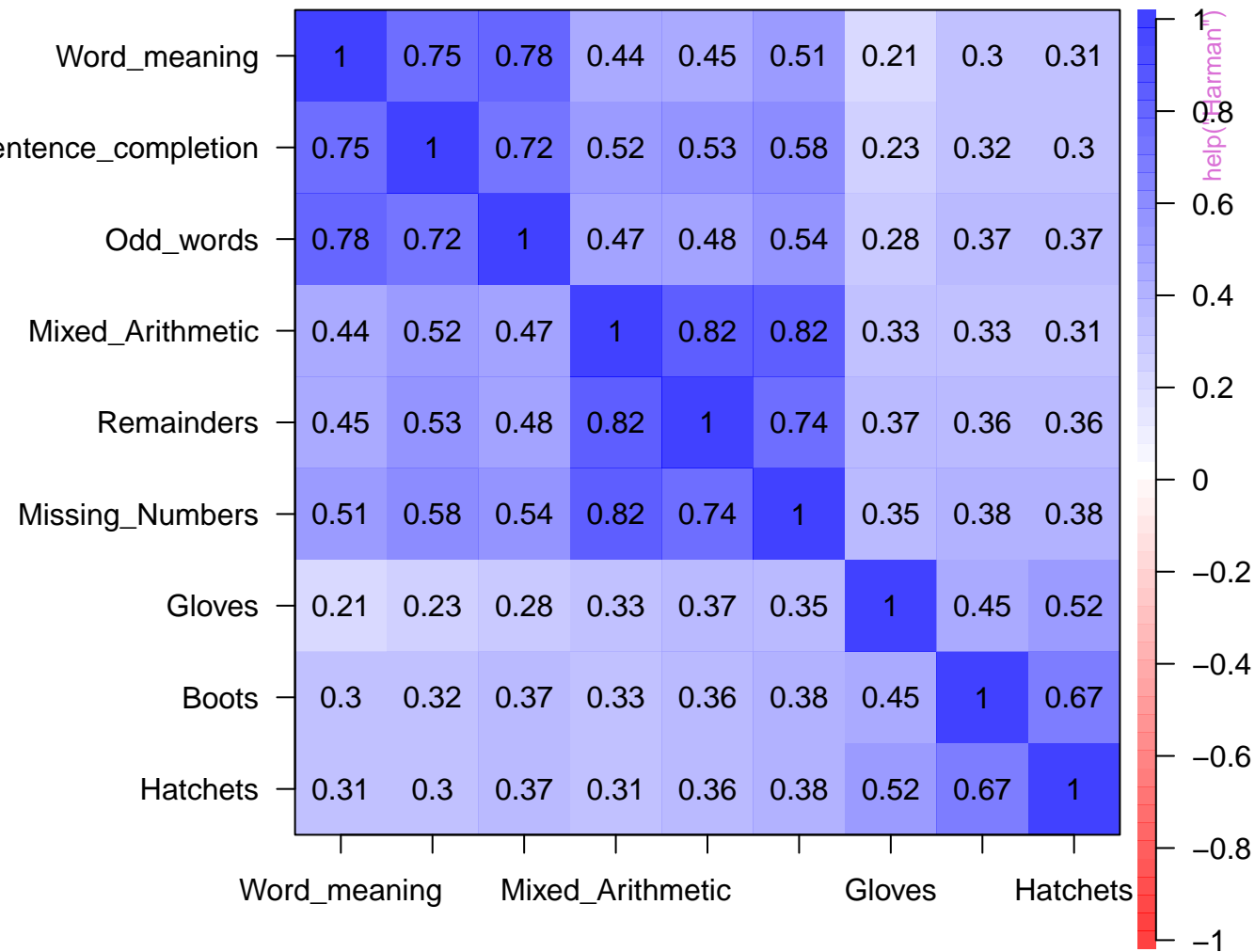

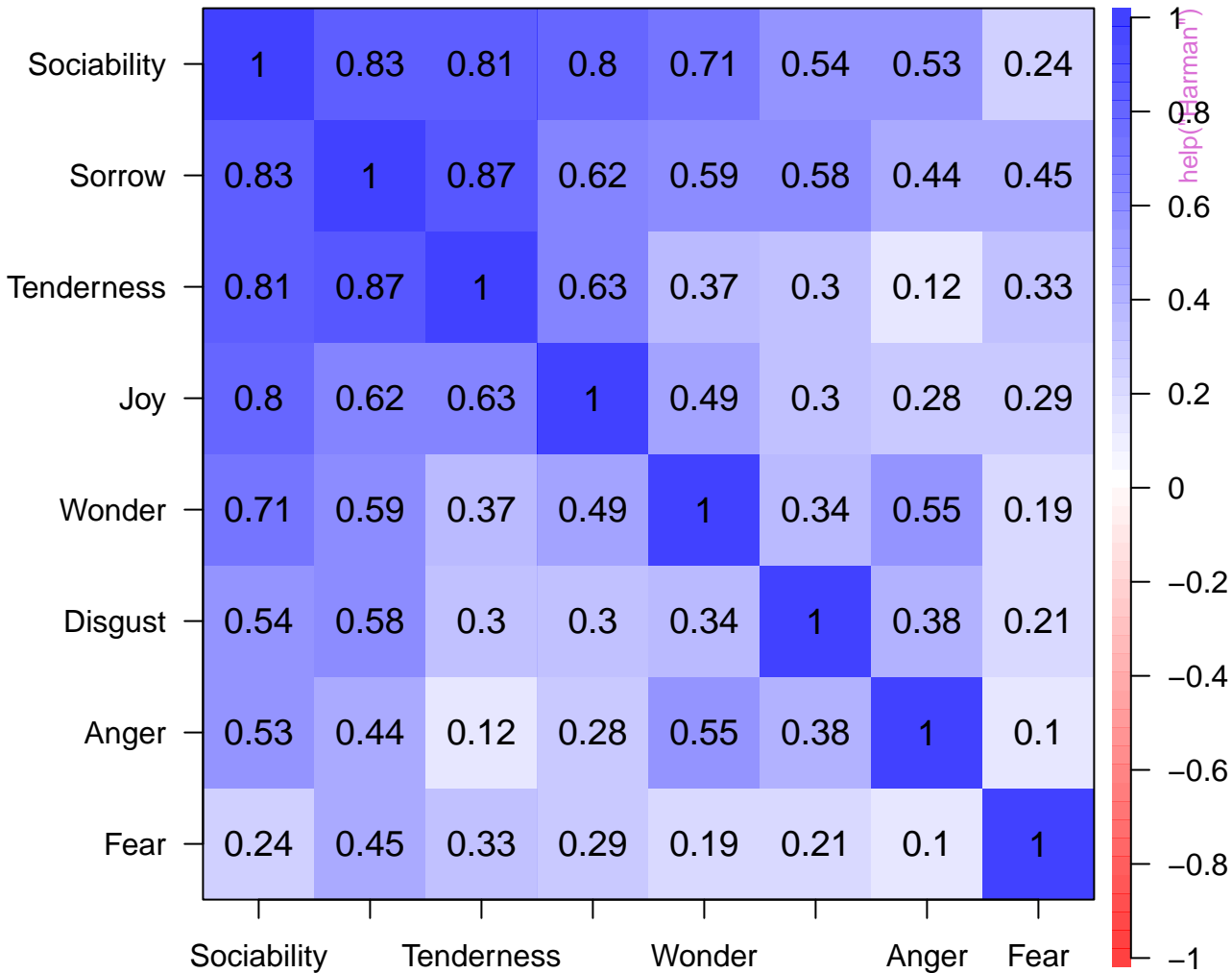

ICLUST of the Harman data

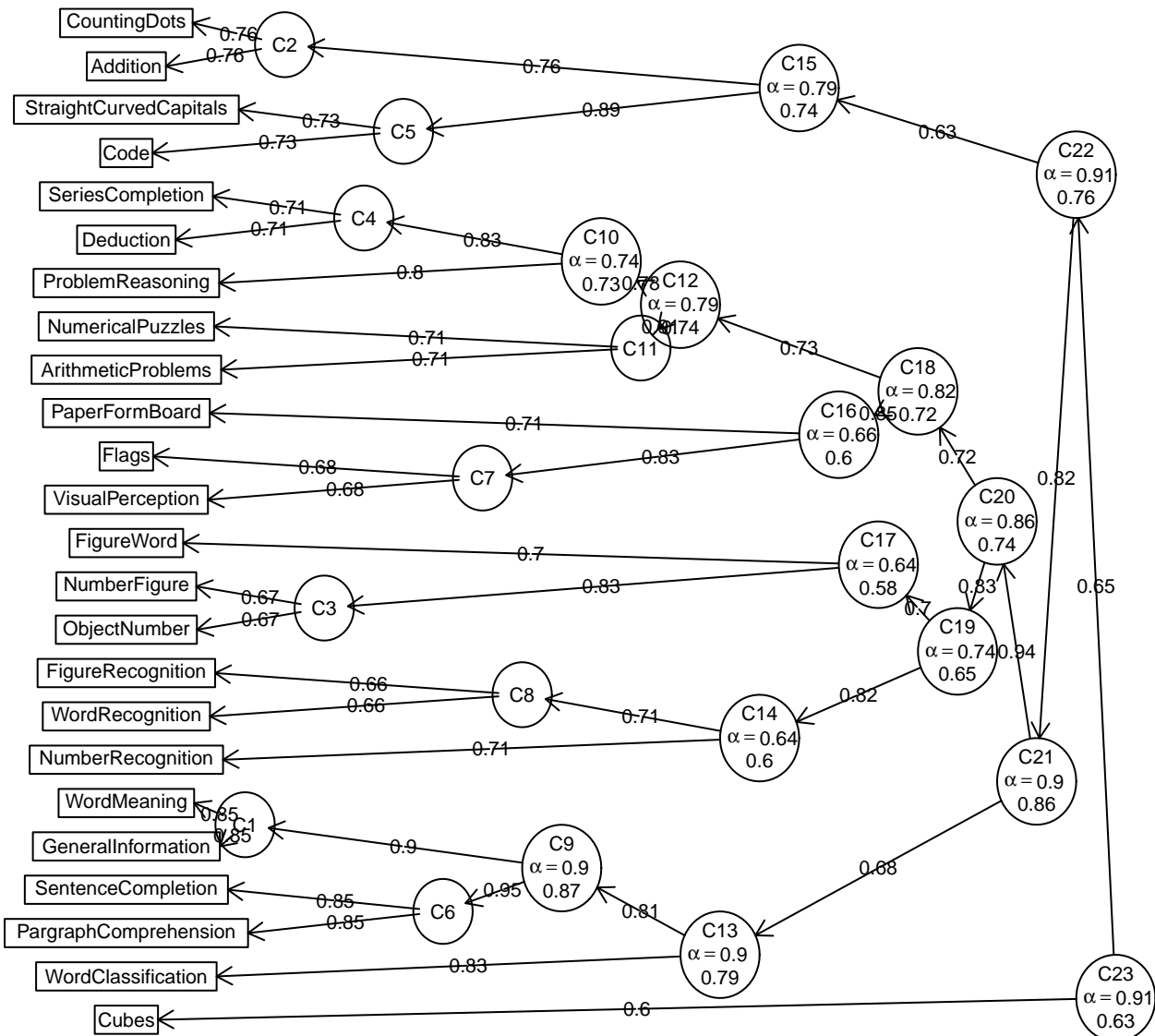

Force 4 clusters

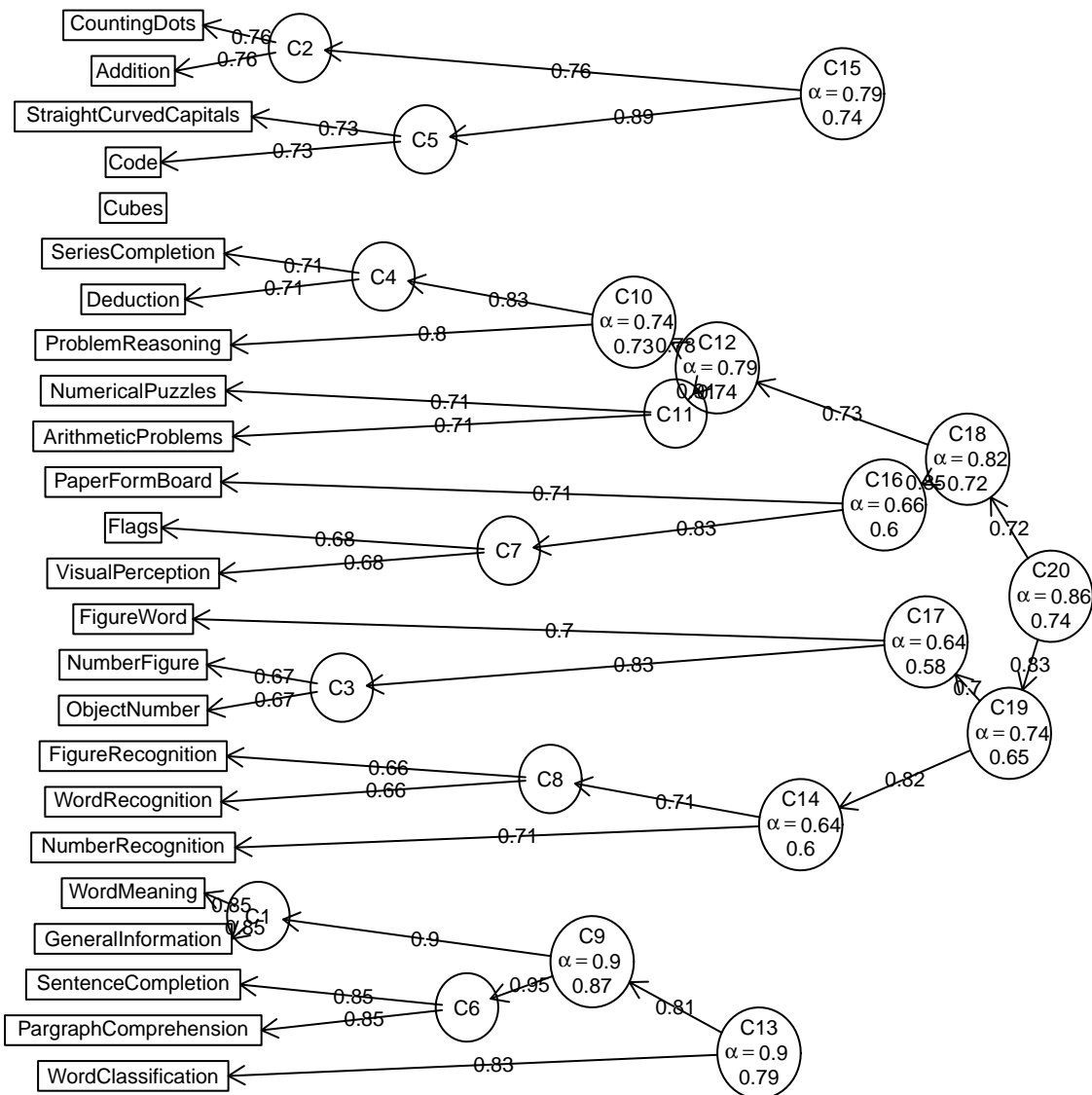

ICLUST

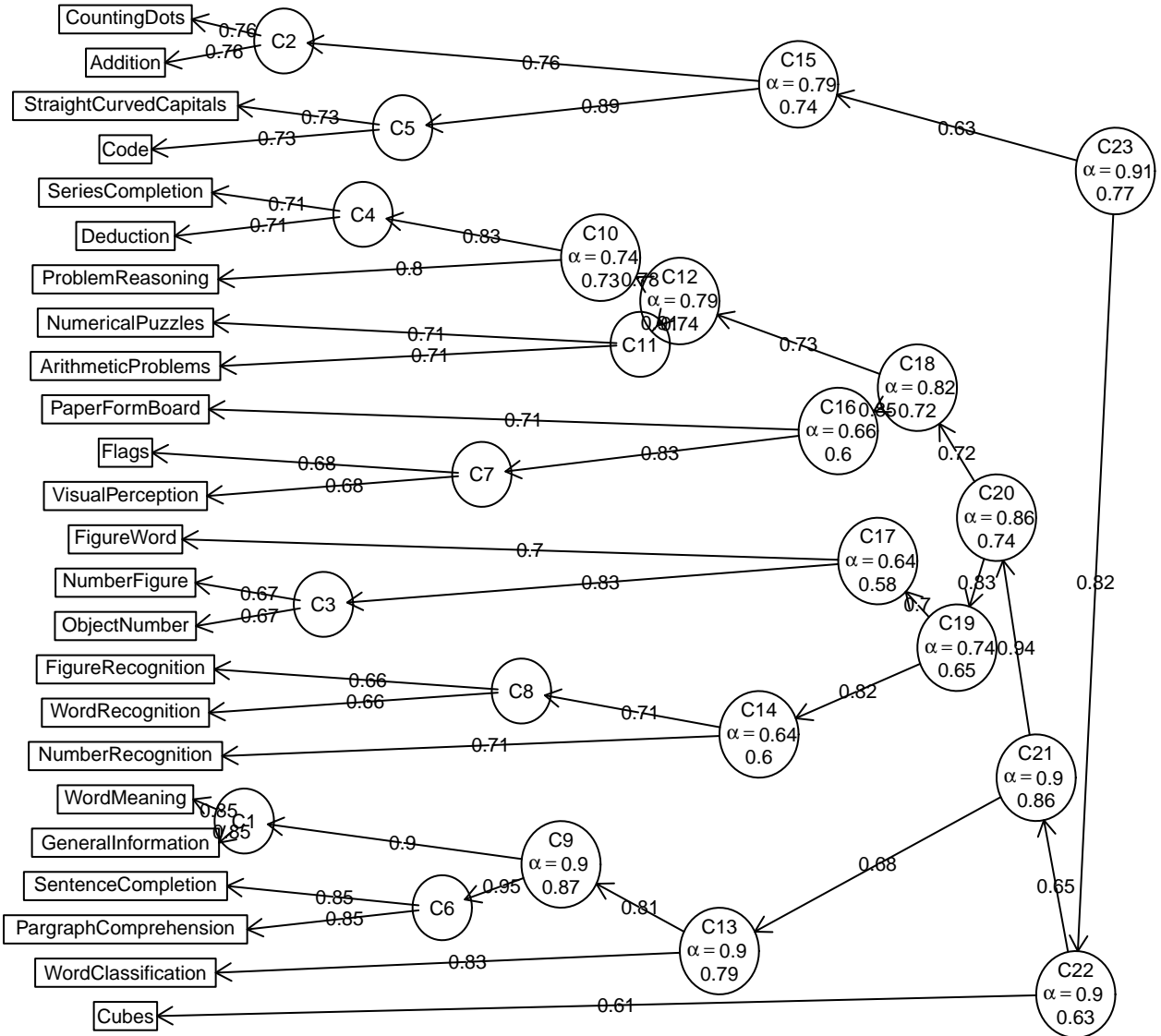

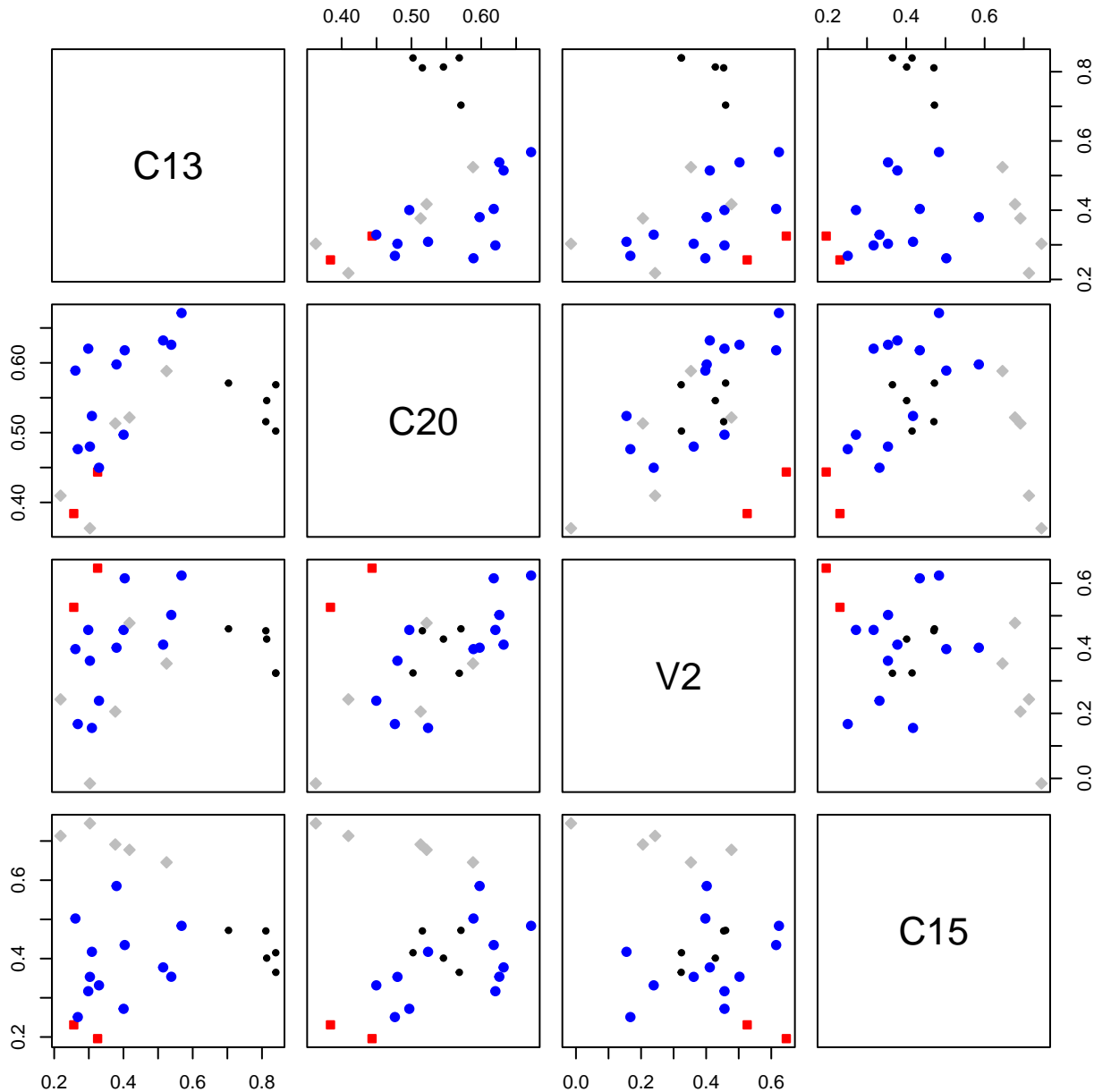

Pattern taken from iclust

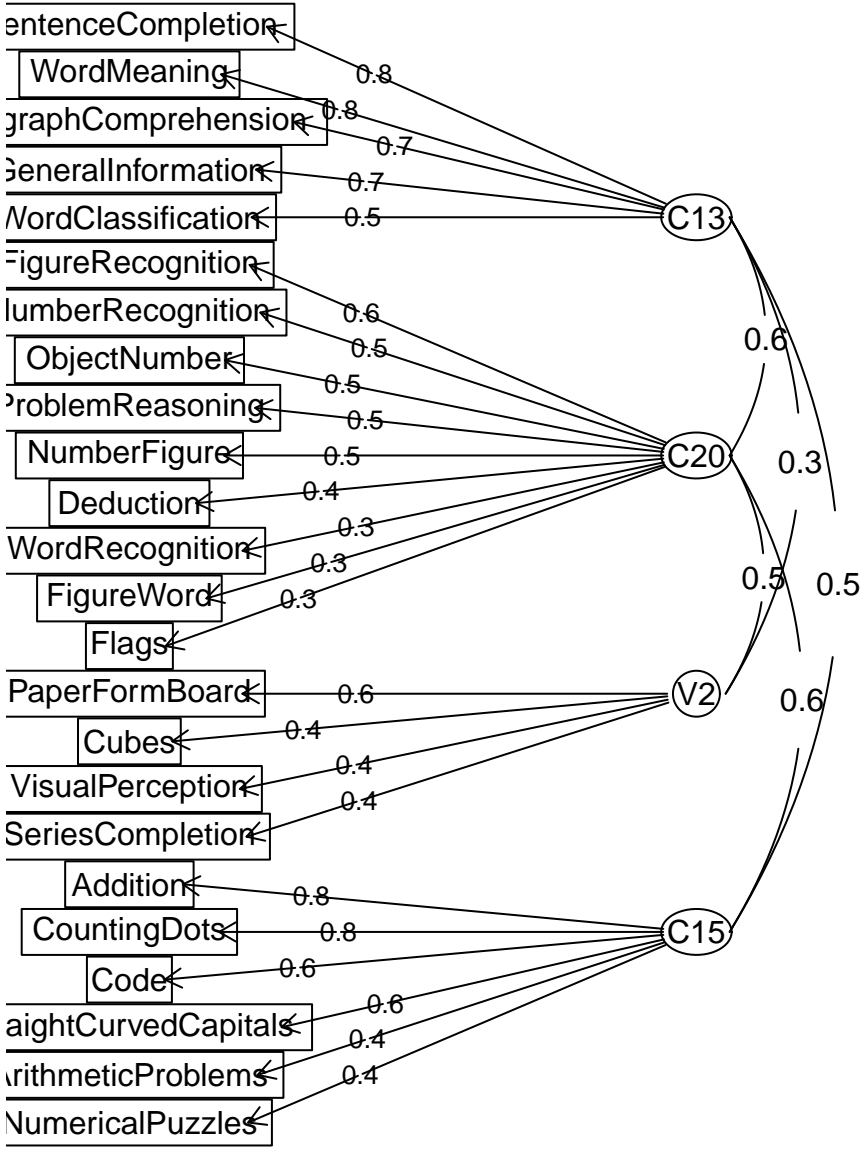

ICLUST

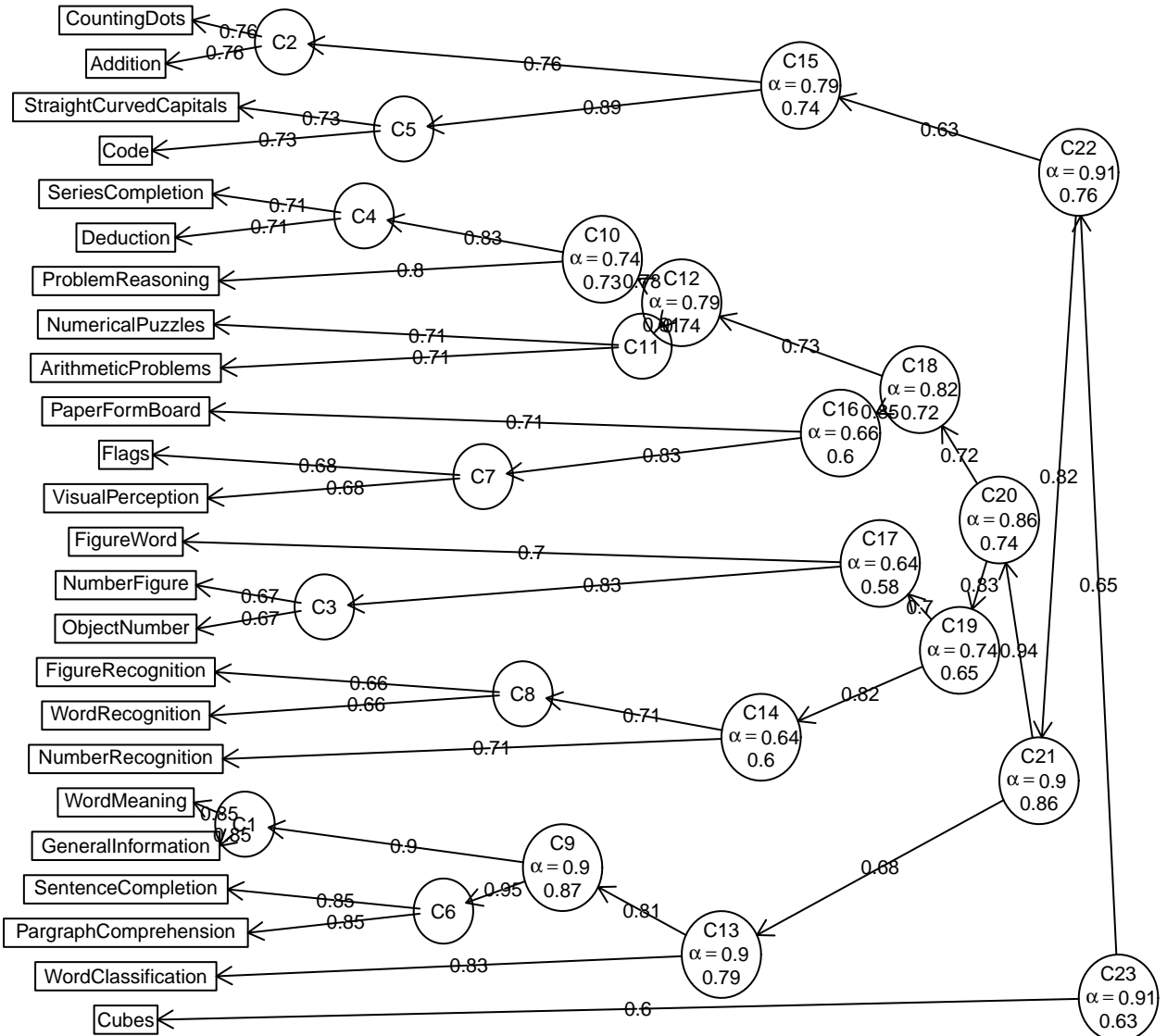

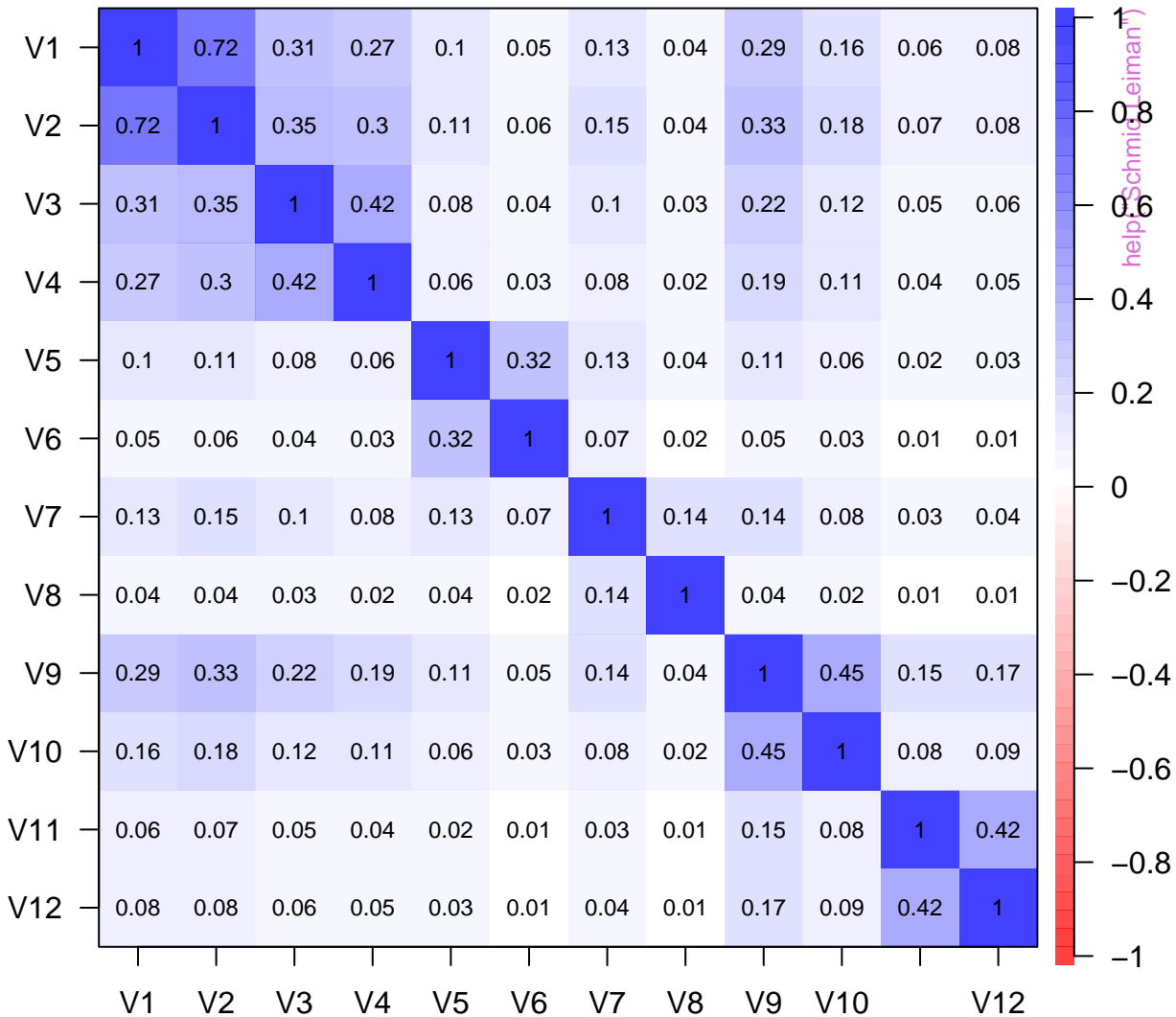

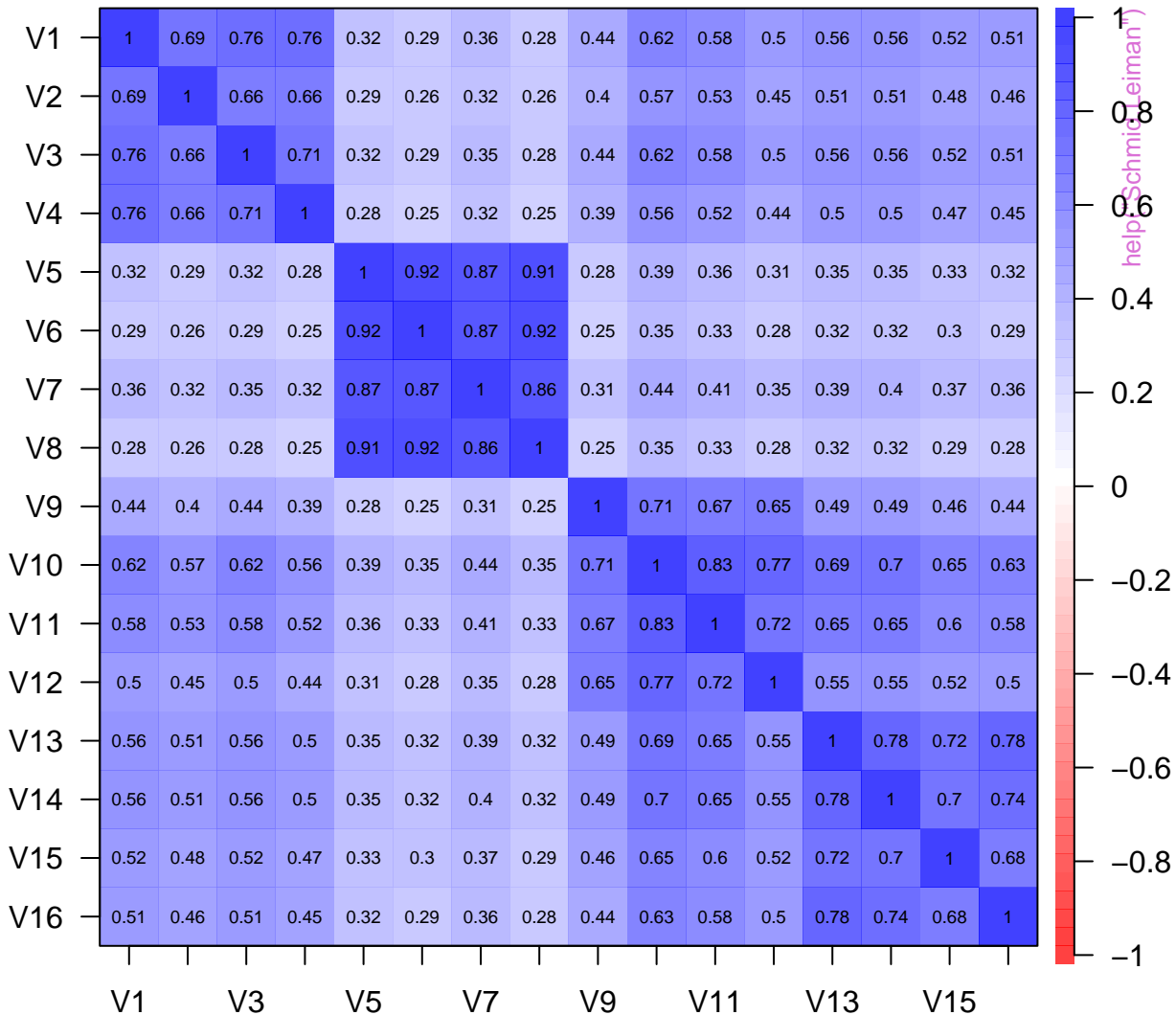

Omega

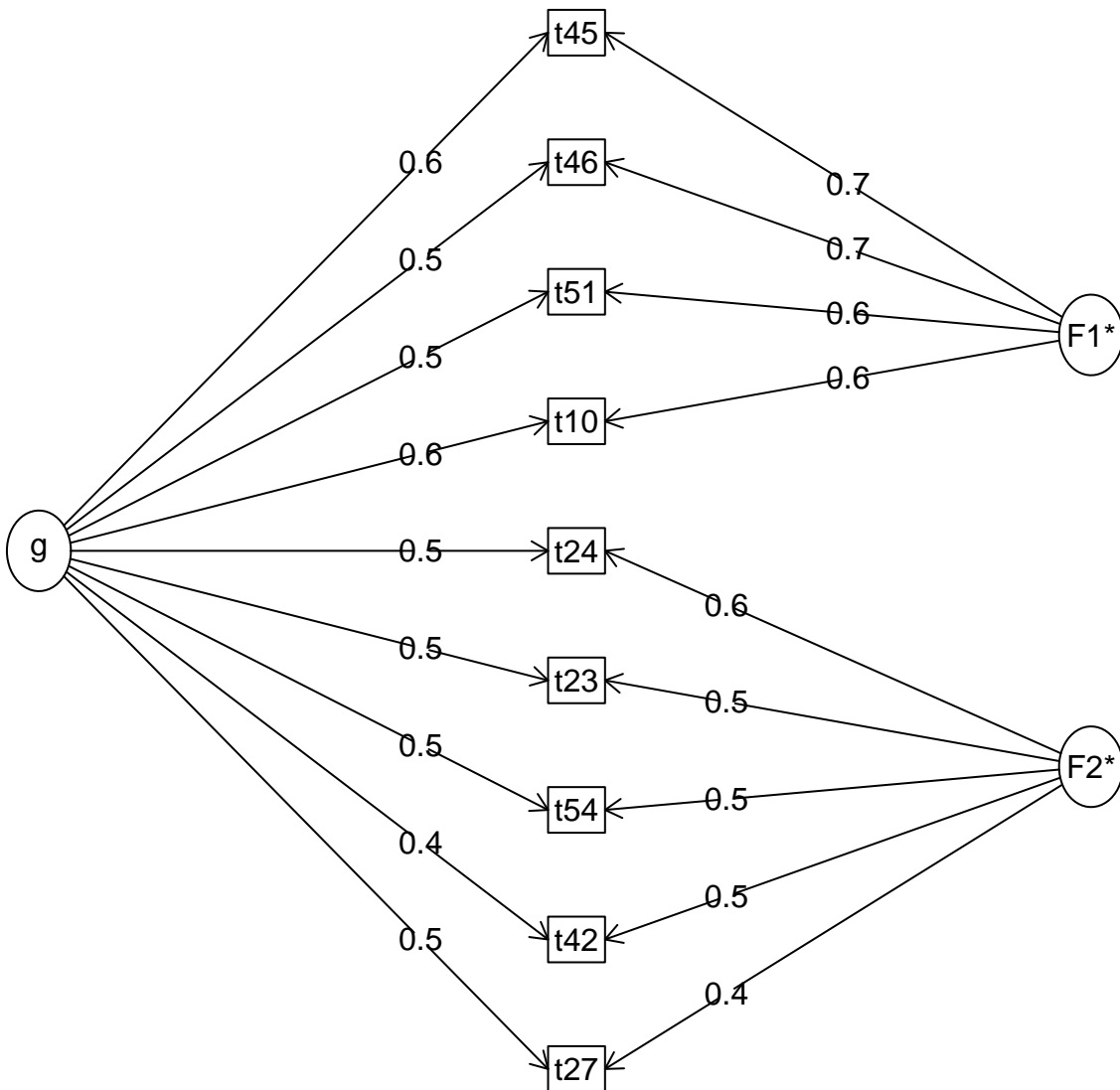

VSS of 24 simple structure variables

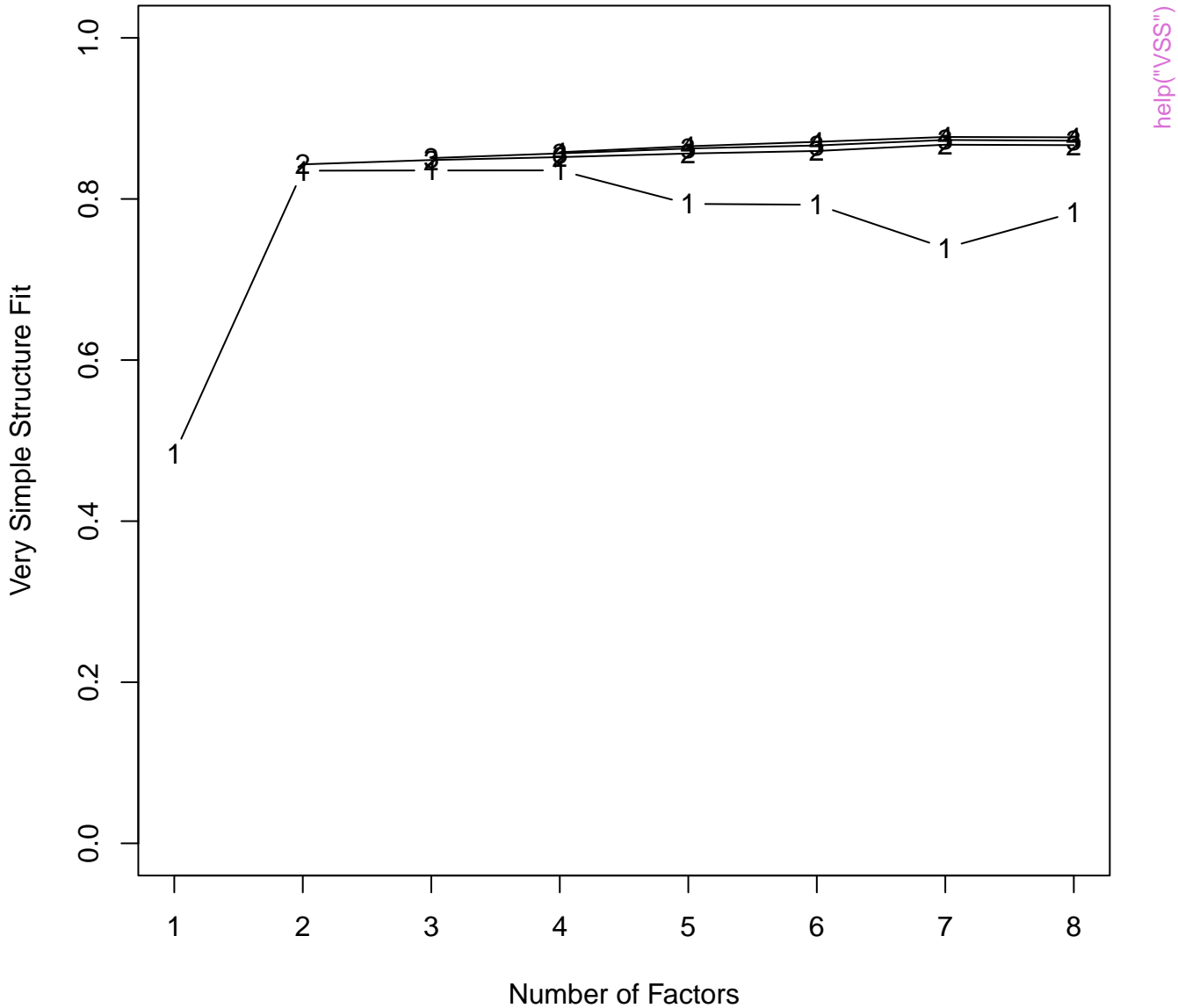

Very Simple Structure

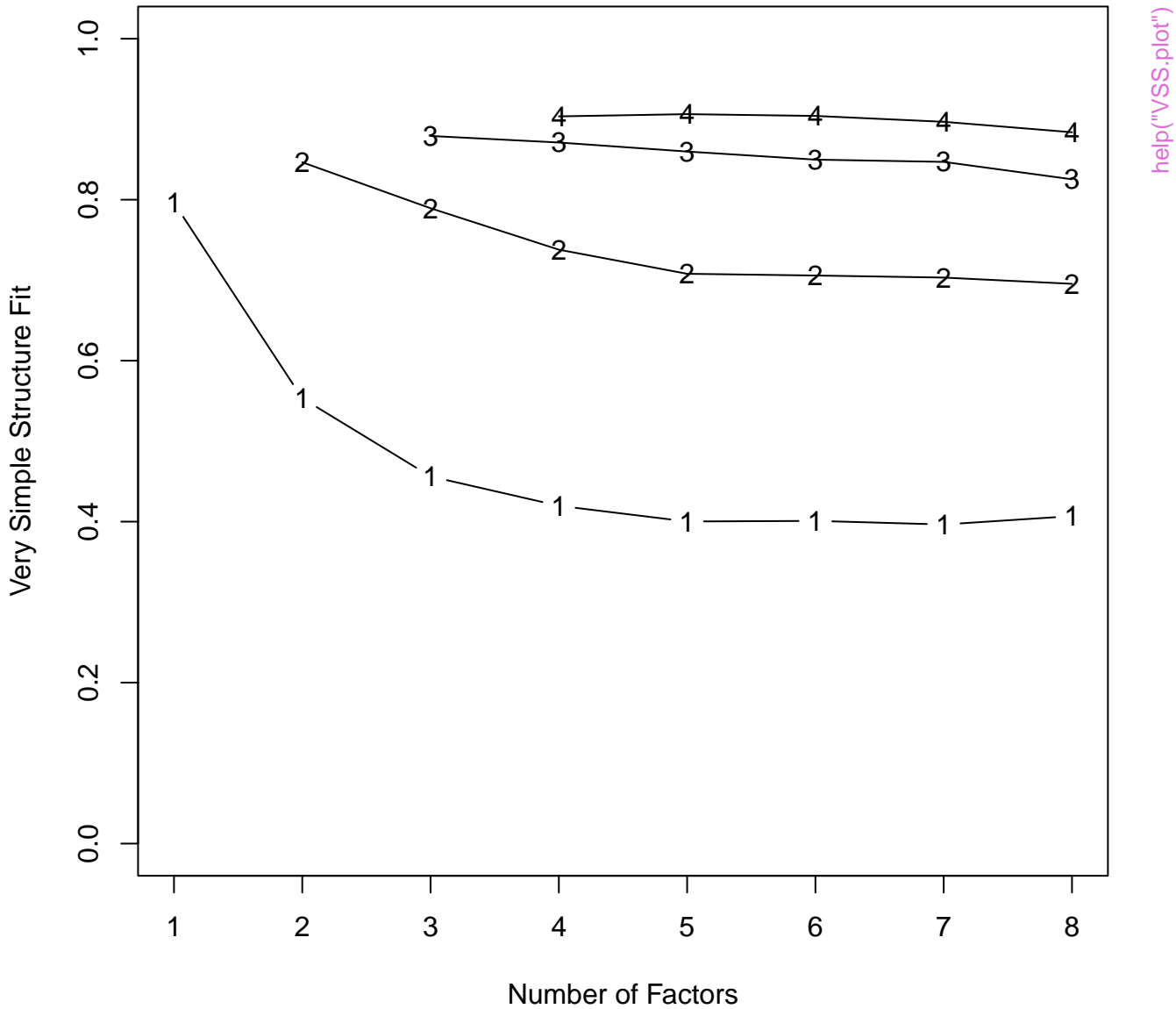

VSS of Holzinger–Harmon problem

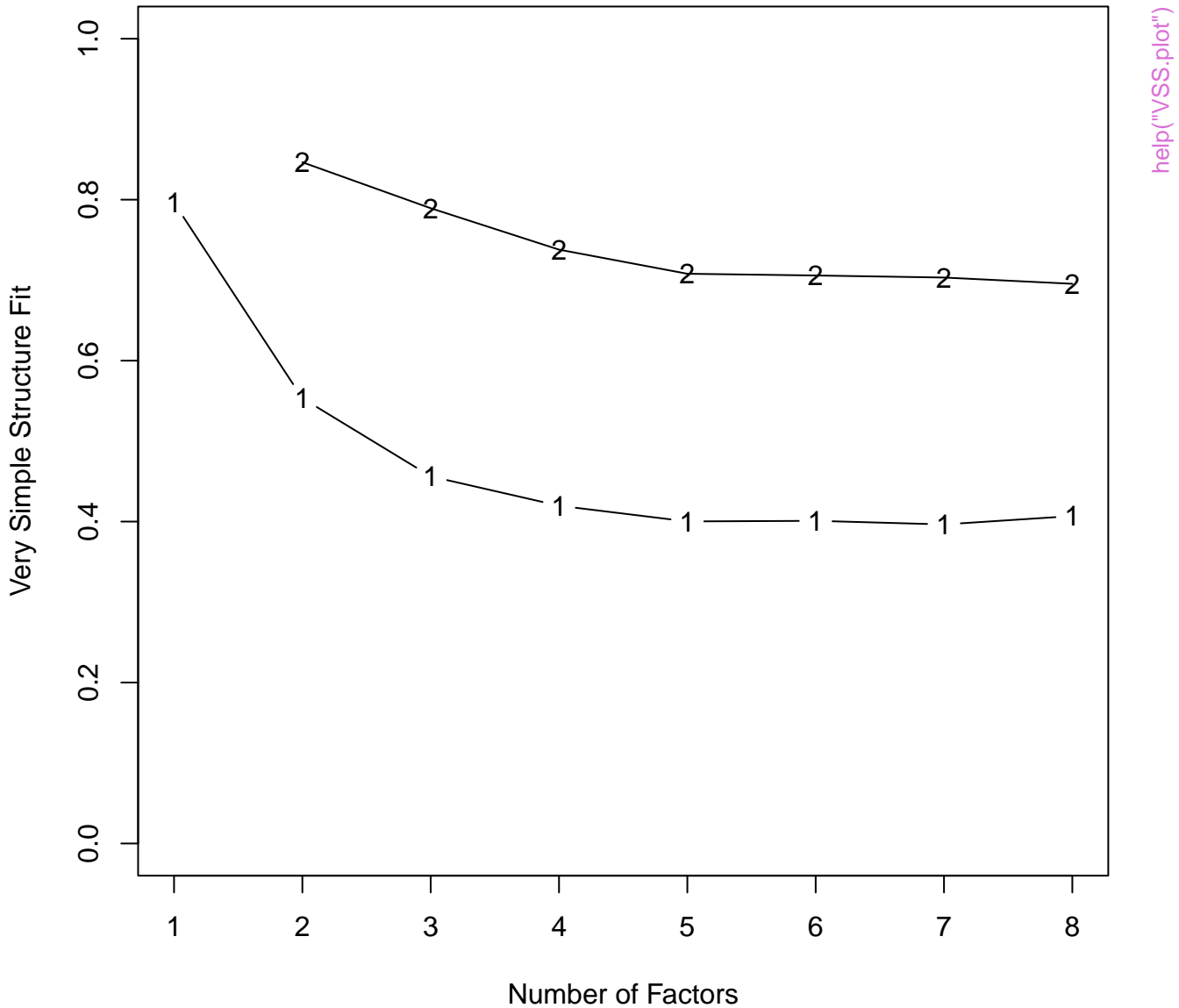

Scree plot

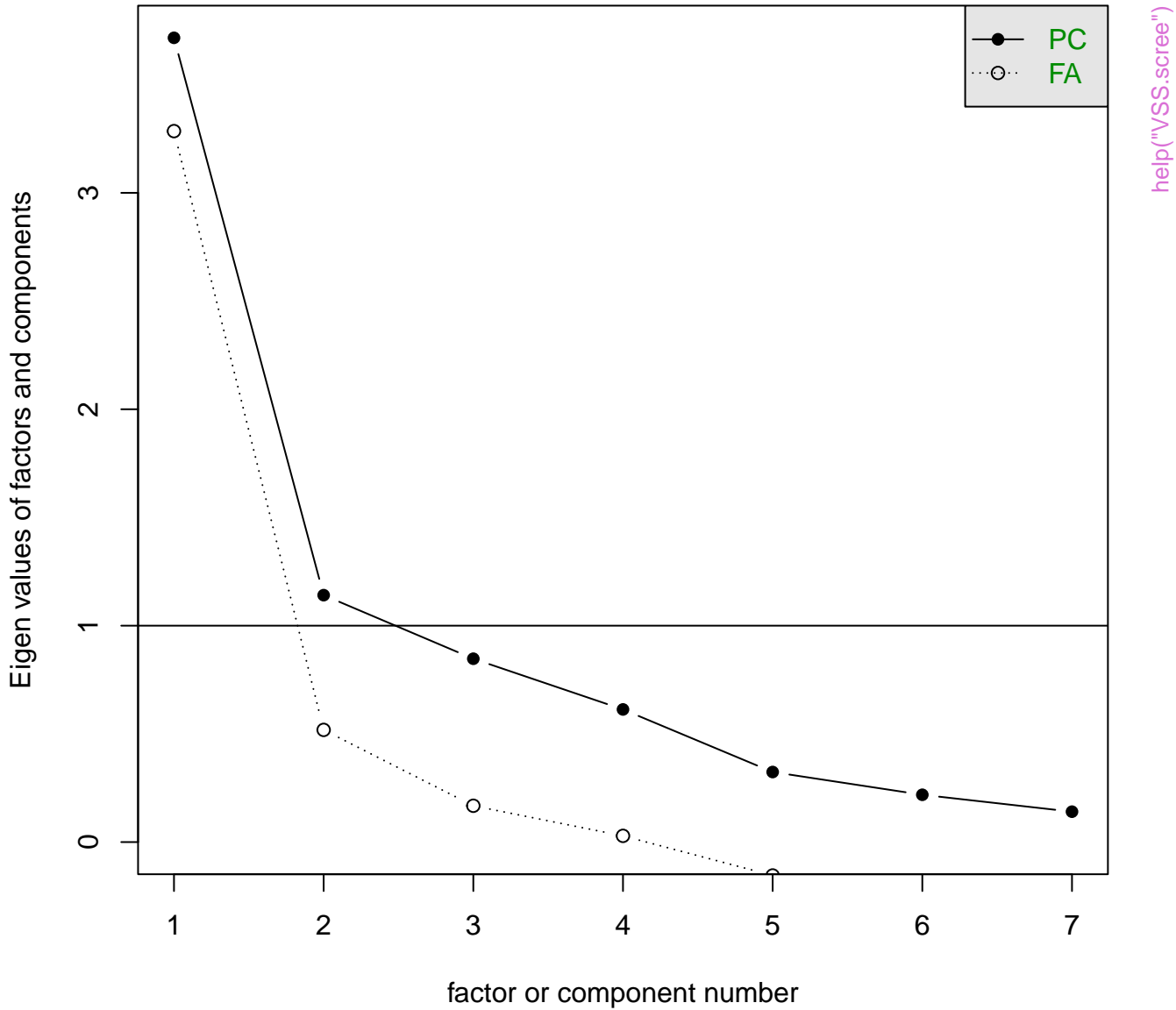

help("VSS.scree")

Regression Models

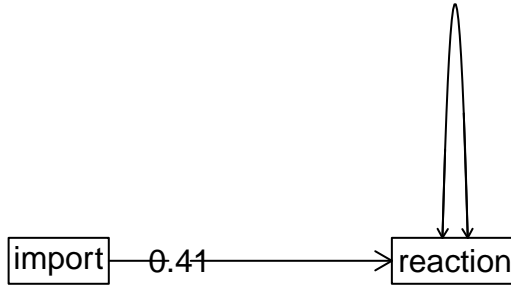

Regression Models

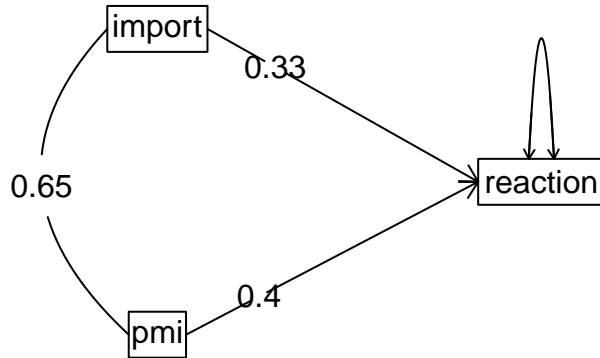

Regression Models

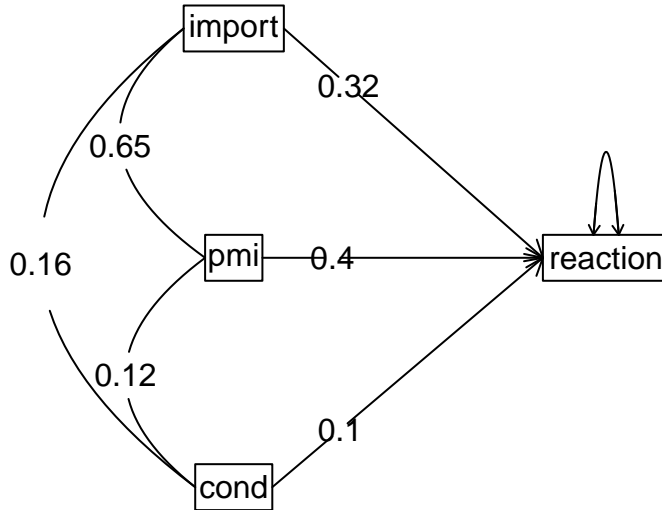

Mediation

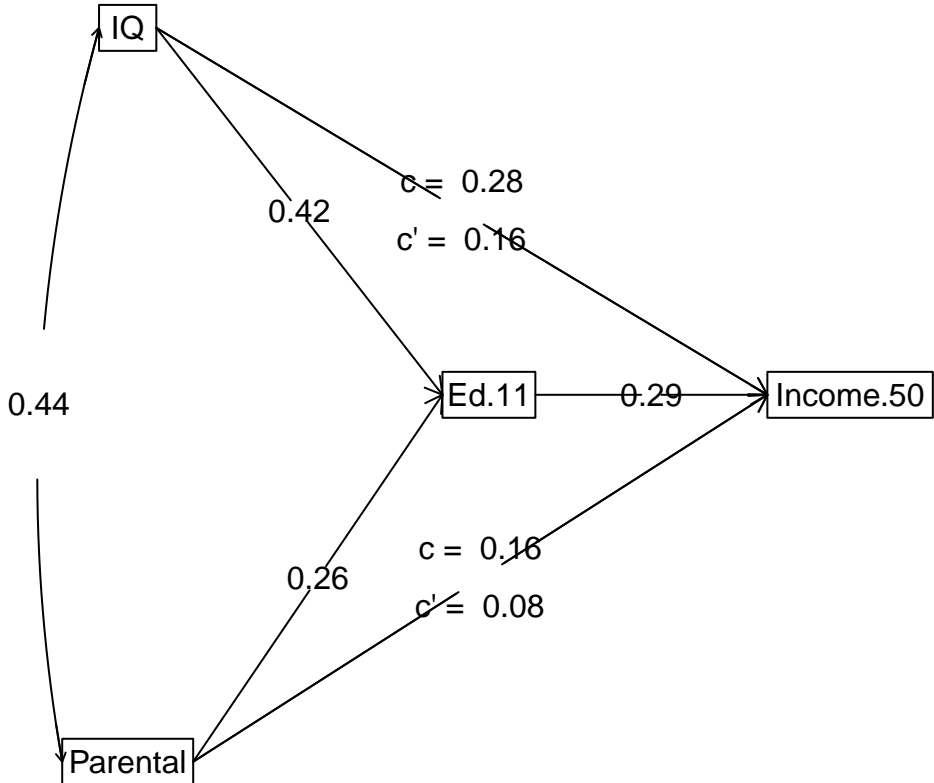

Mediation

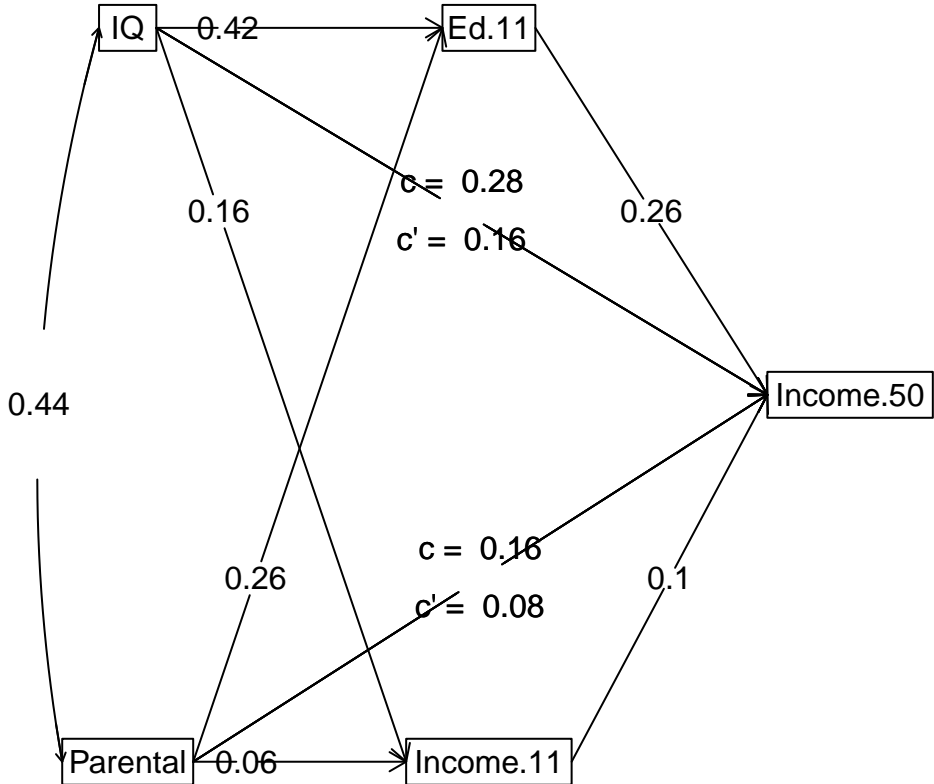

Thurstone data set

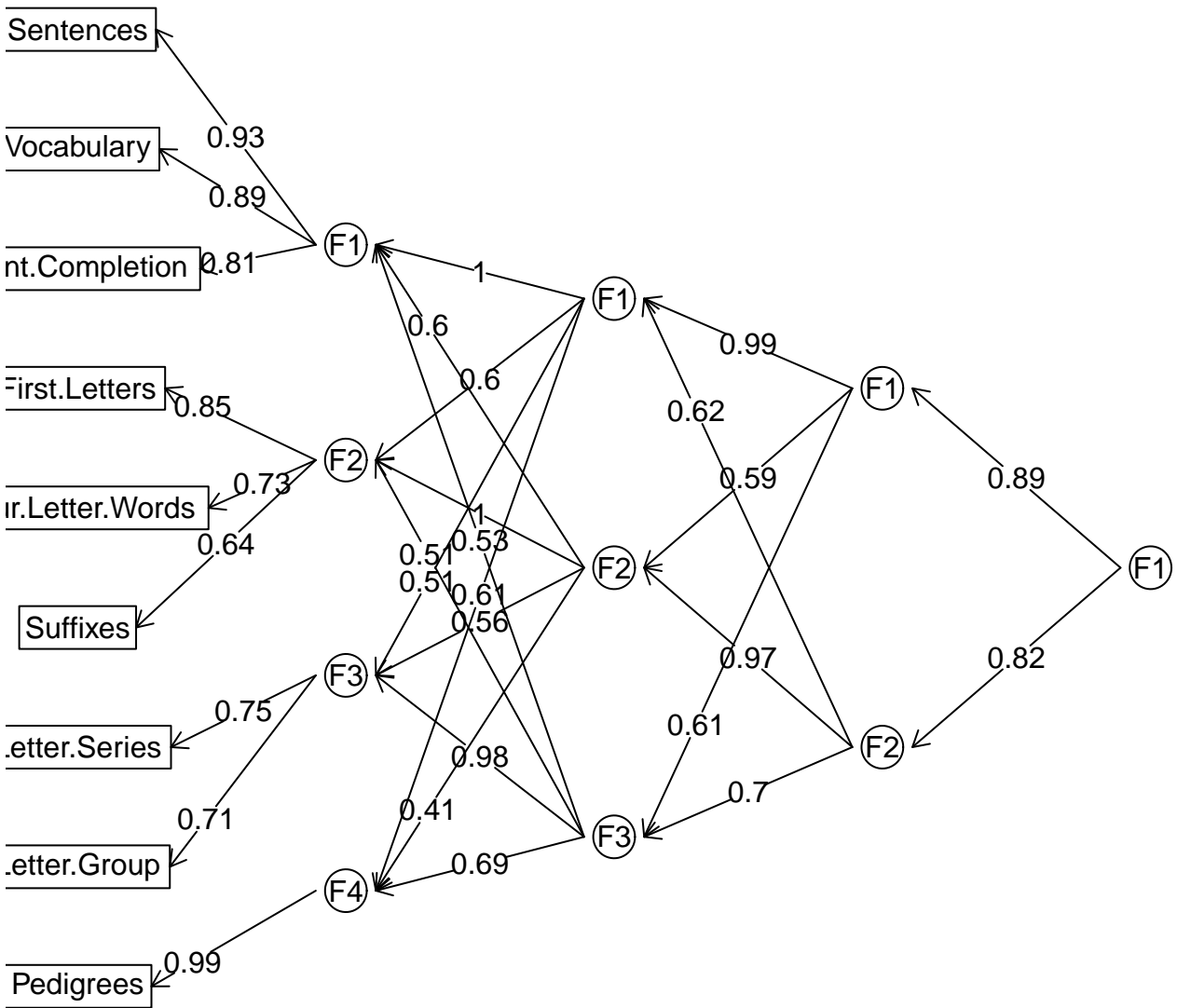

bfi data set from psychTools

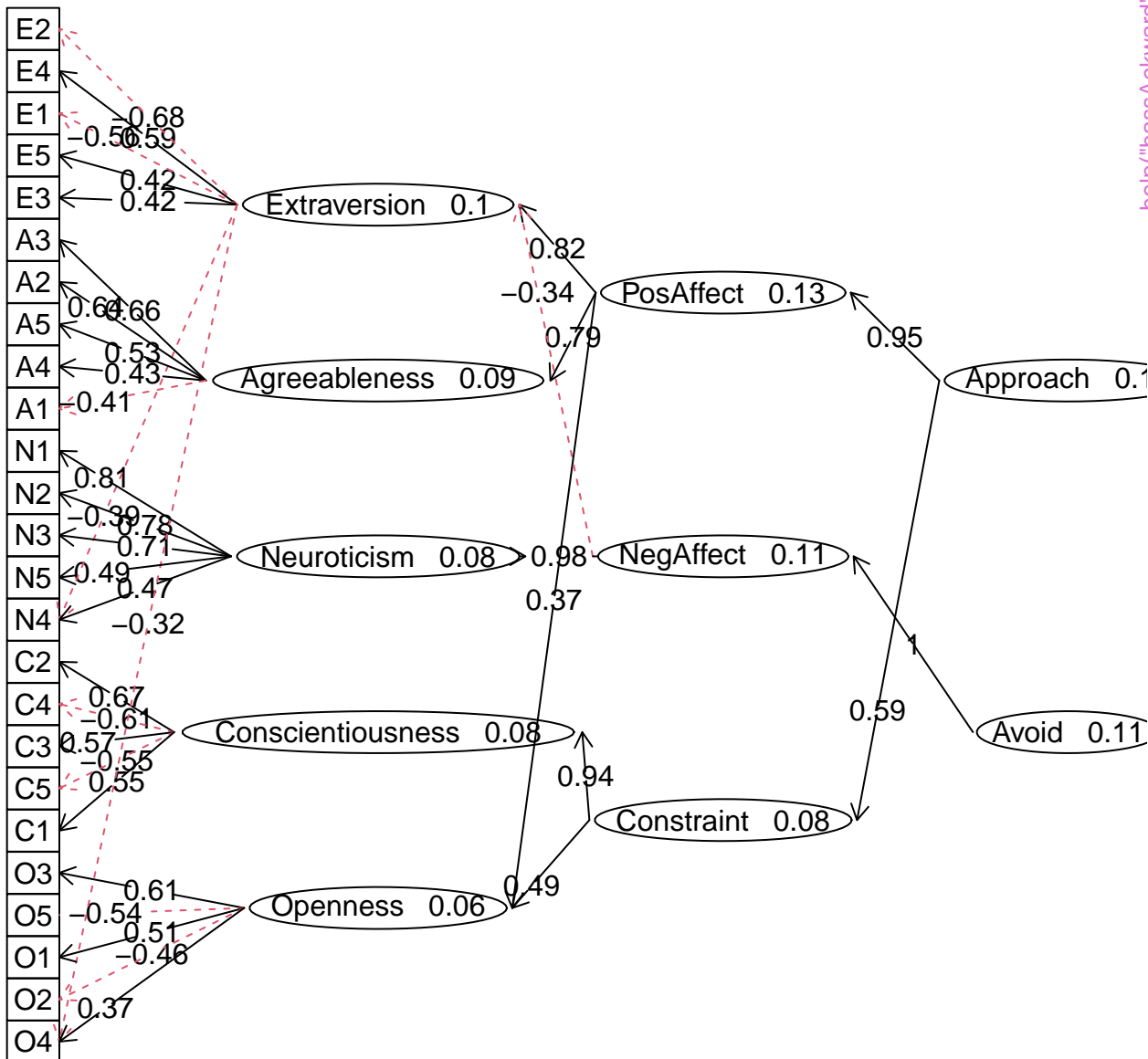

Age by males and females

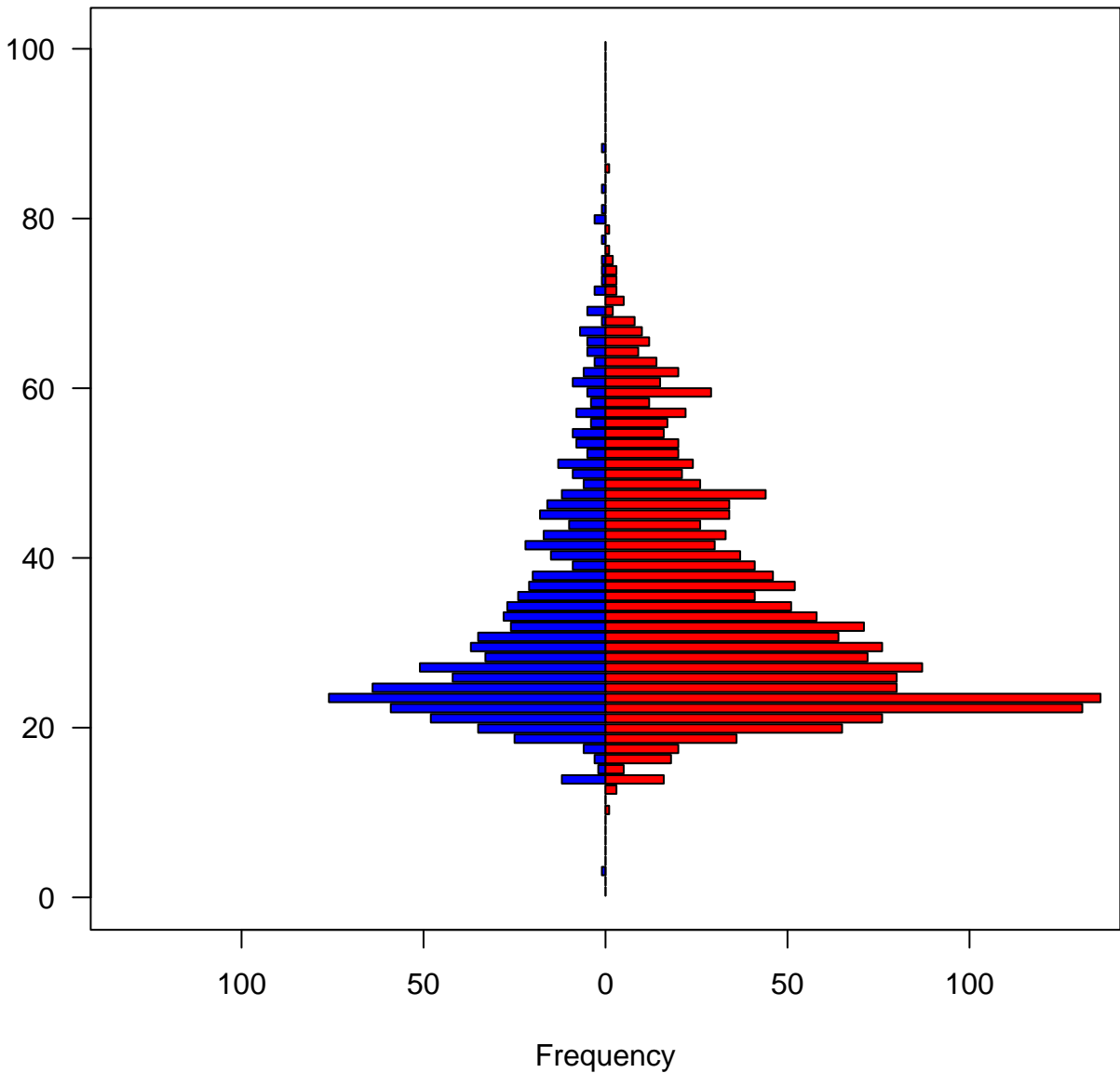

help("bi.bars")

Education by gender

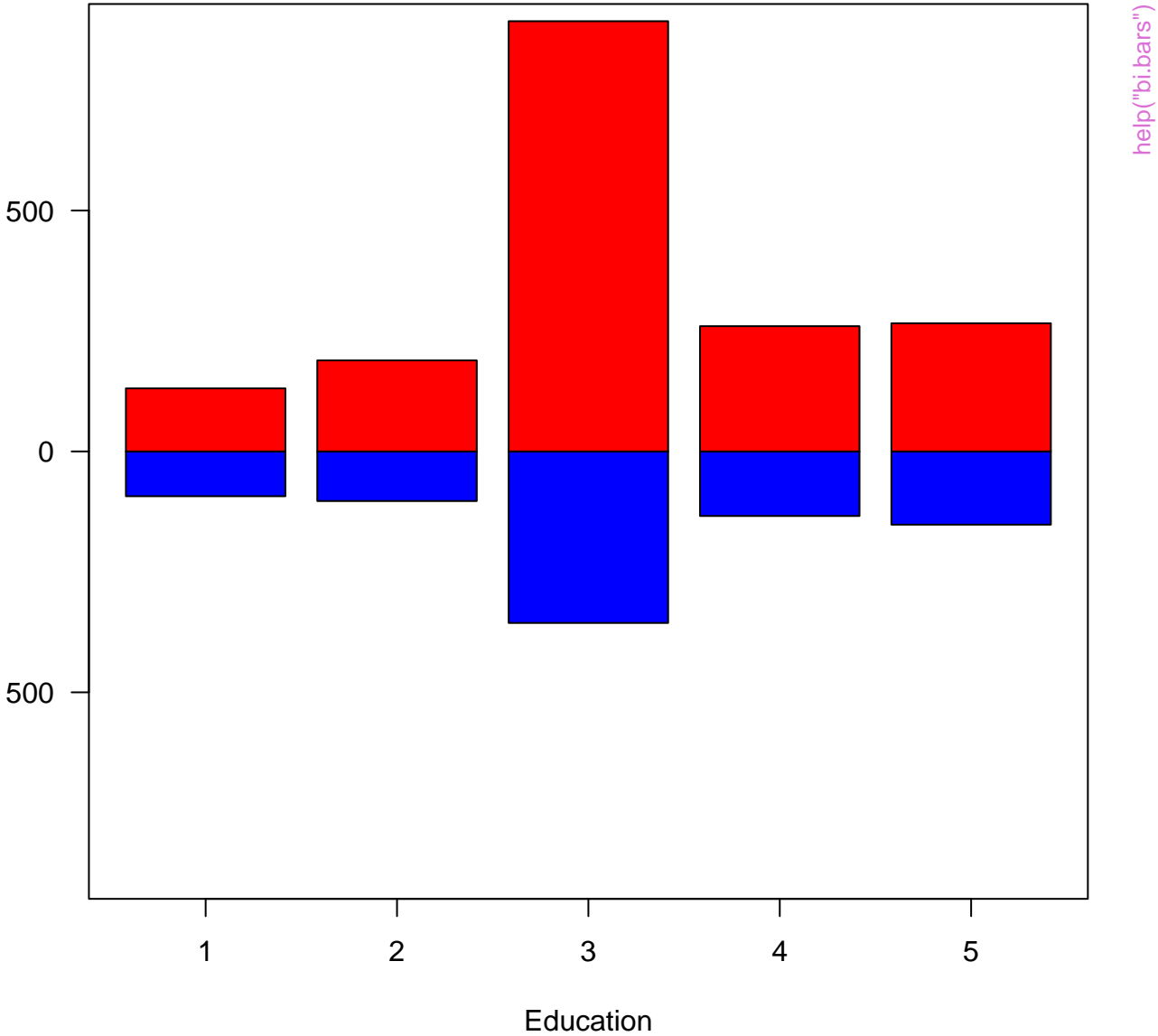

9 variables from Thurstone

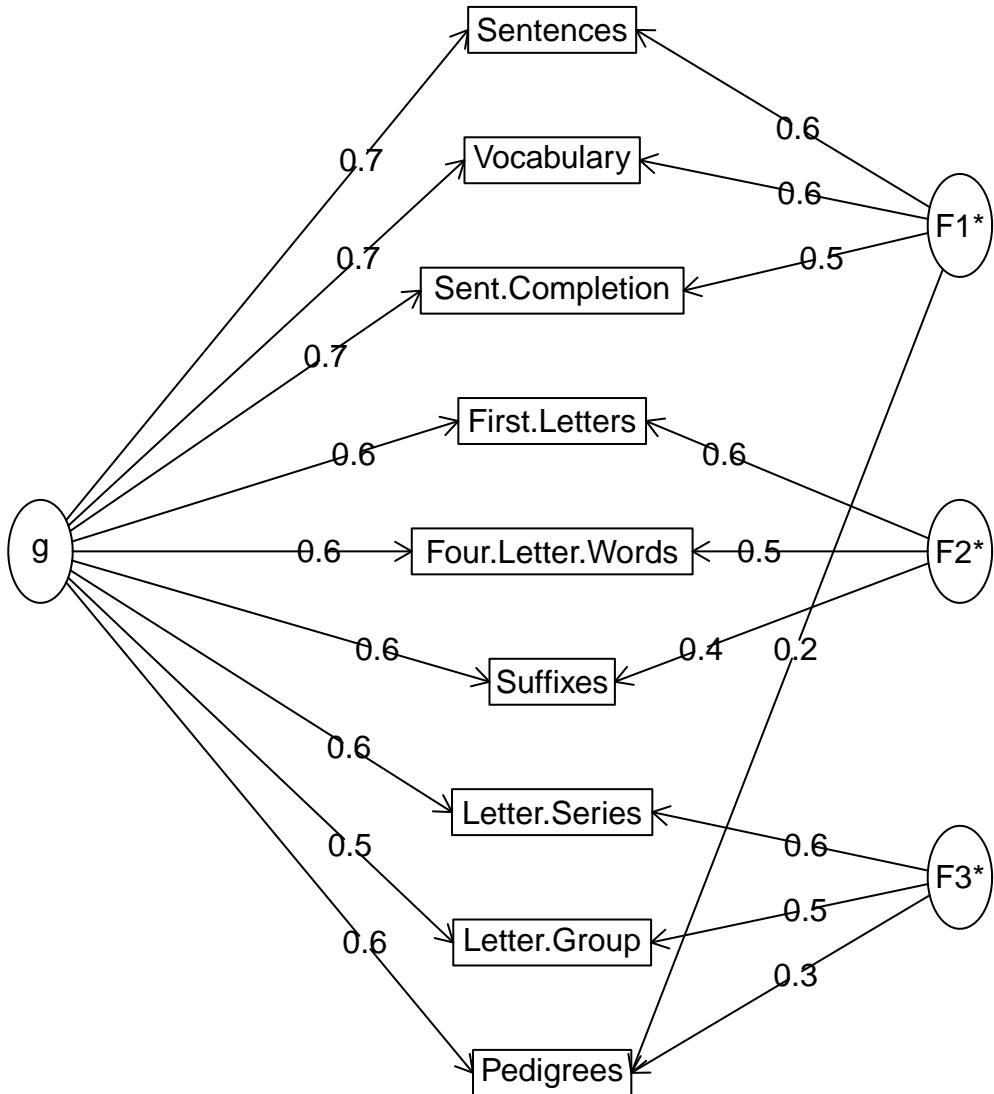

Biplot from fa

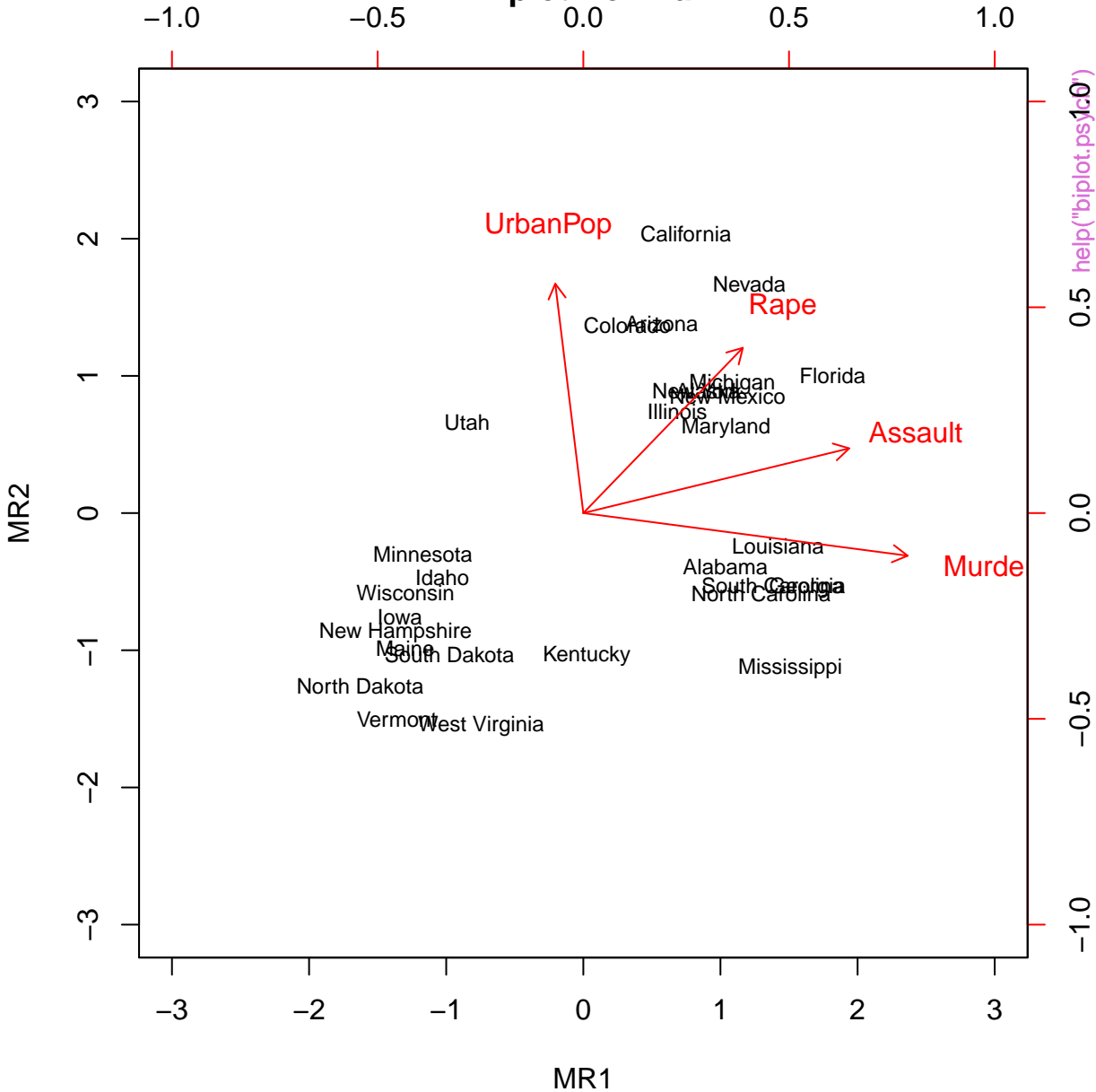

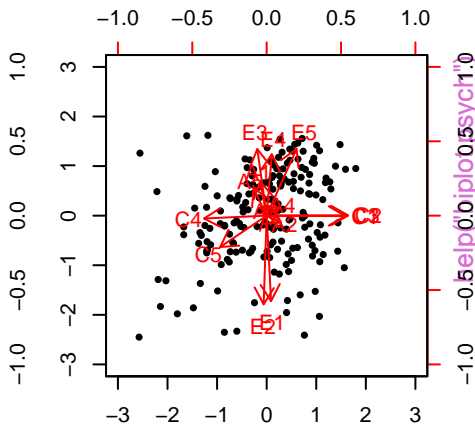
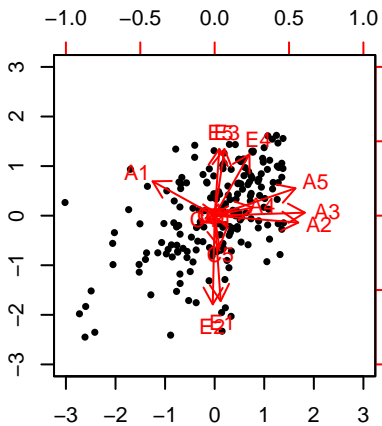
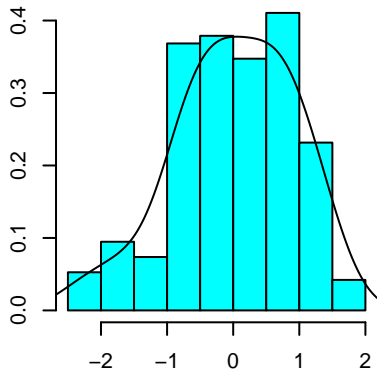
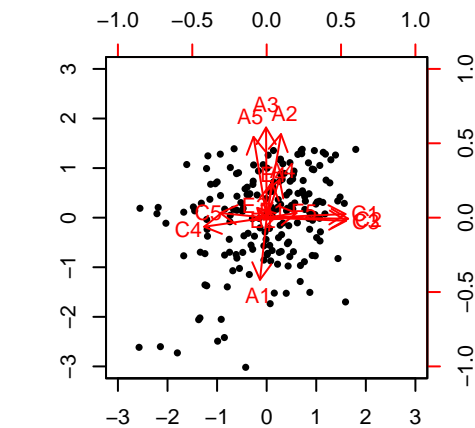
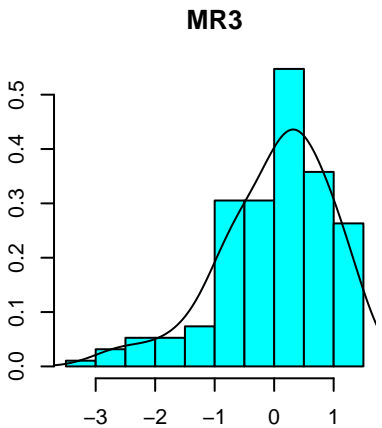
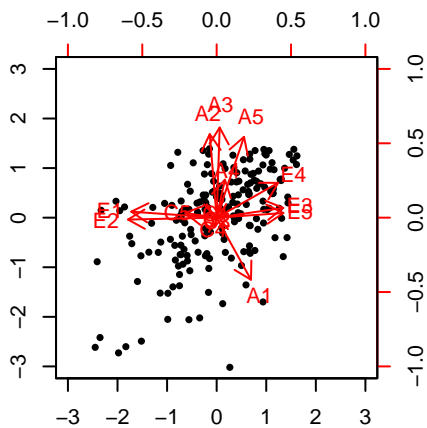
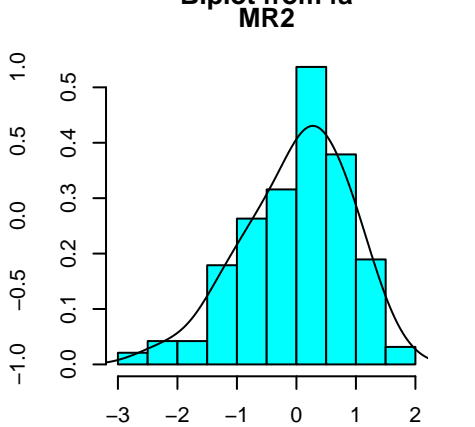
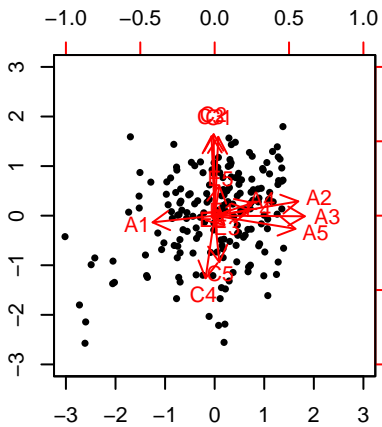
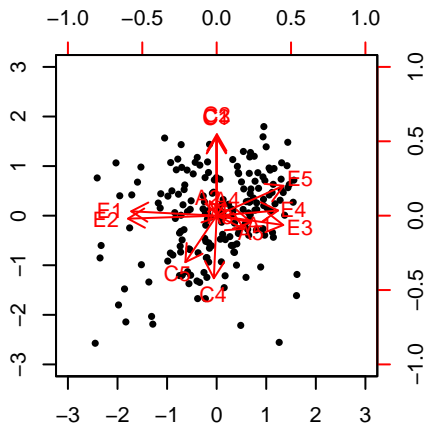
MR1**MR3****Biplot from fa
MR2**

Biplot from fa

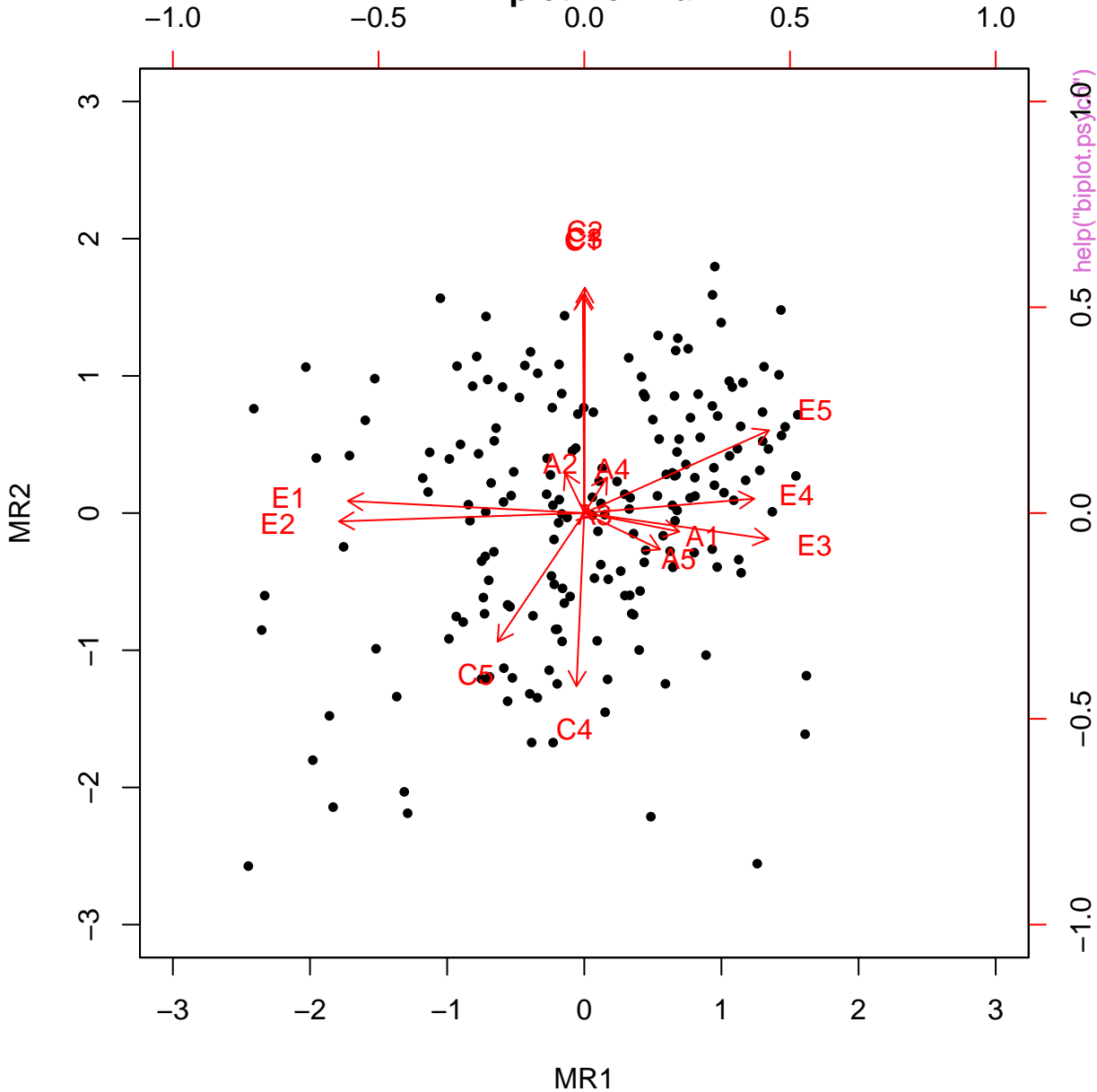

Biplot of Conscientiousness and Neuroticism by gender

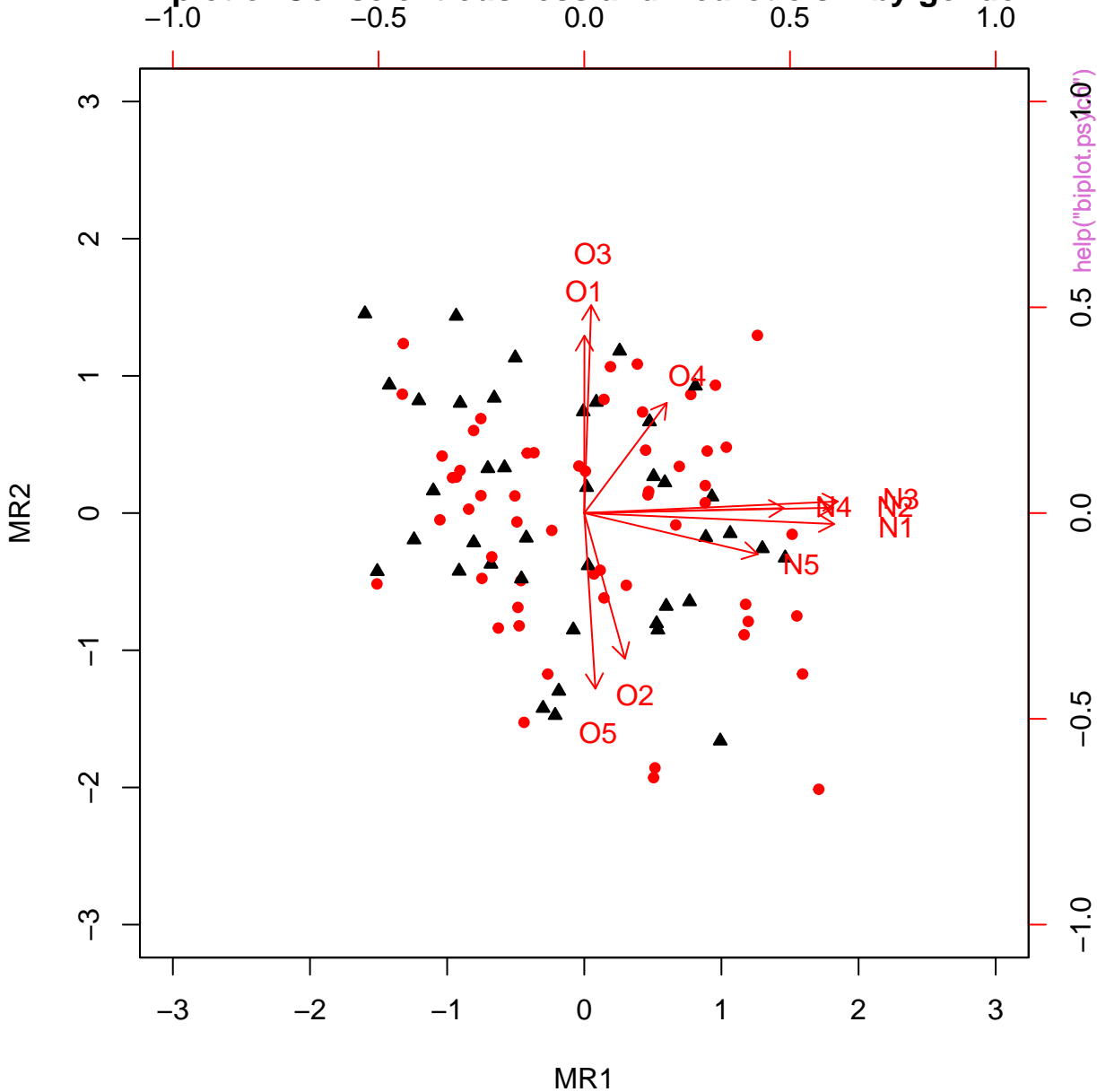

biplot from correlation matrix and factor scores

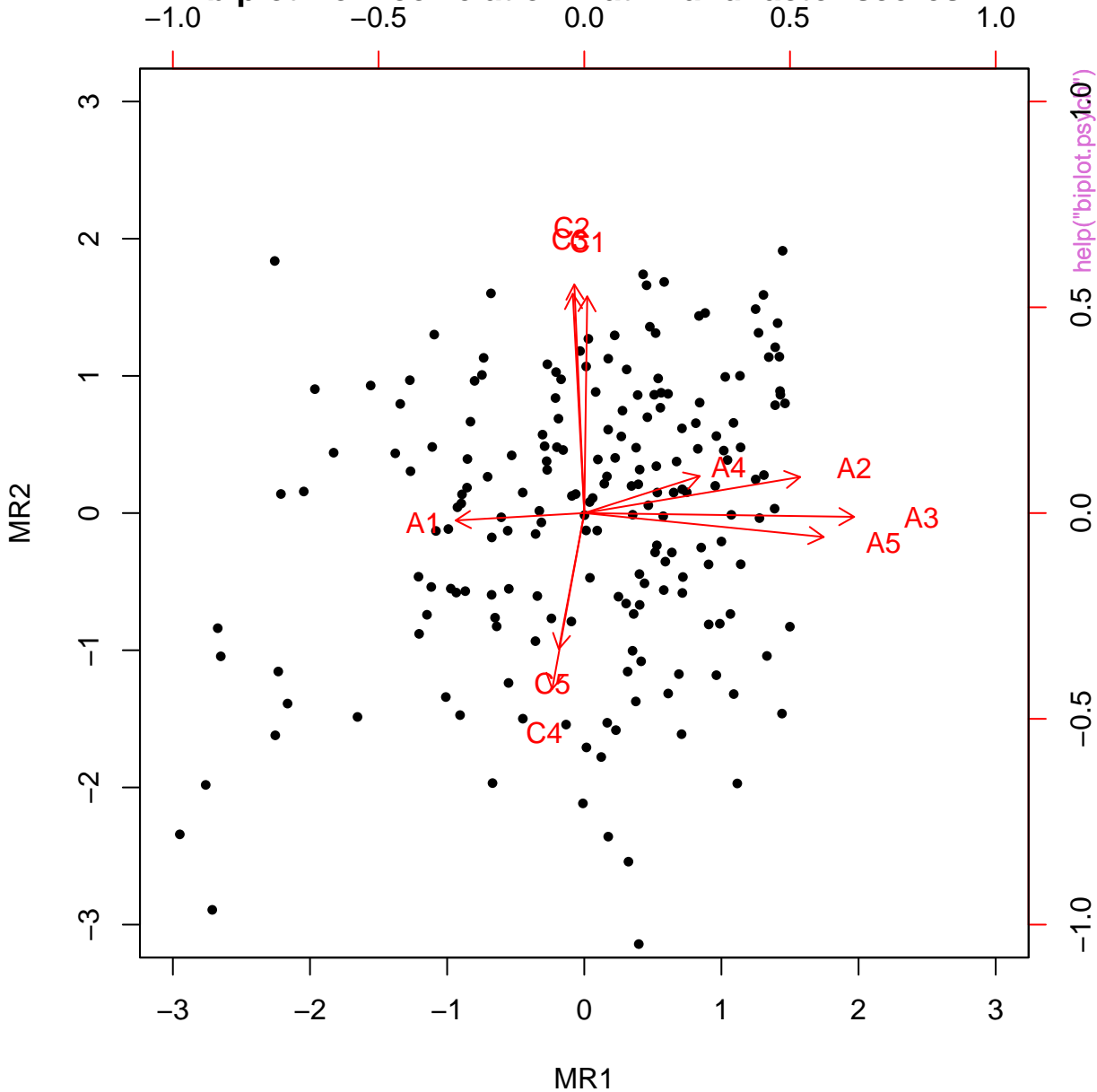

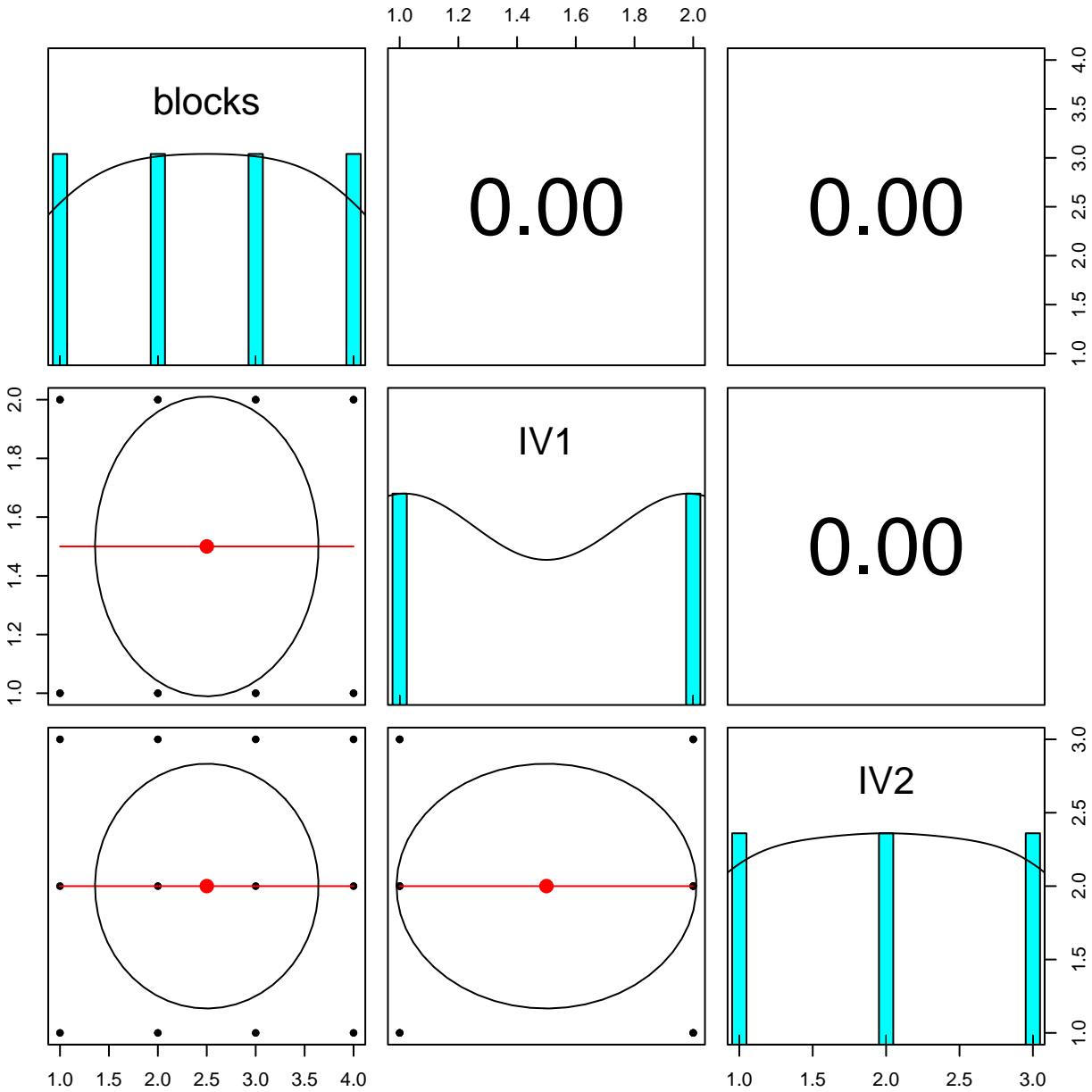

help("block.random")

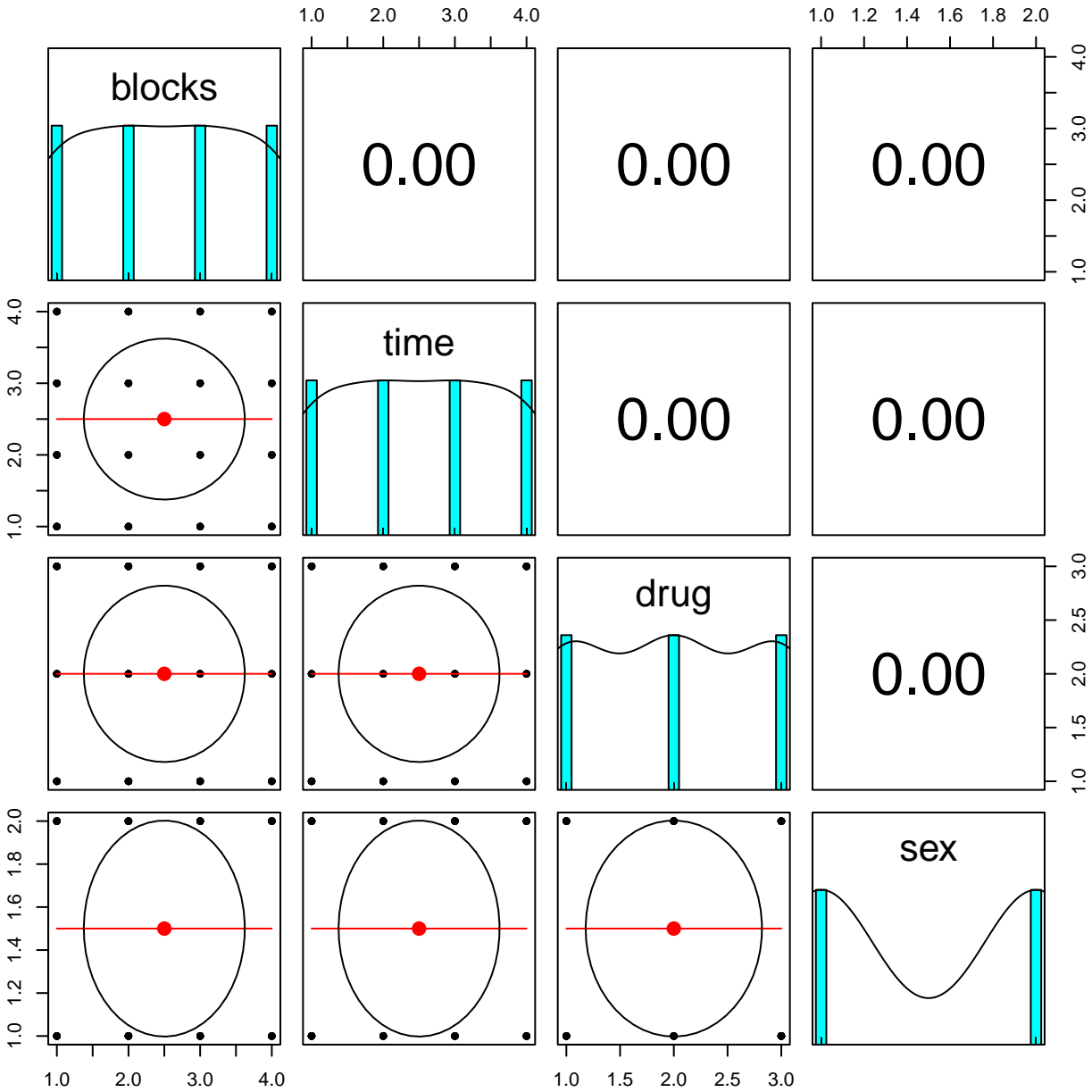

help("block.random")

12 cognitive variables from Cattell (1963)

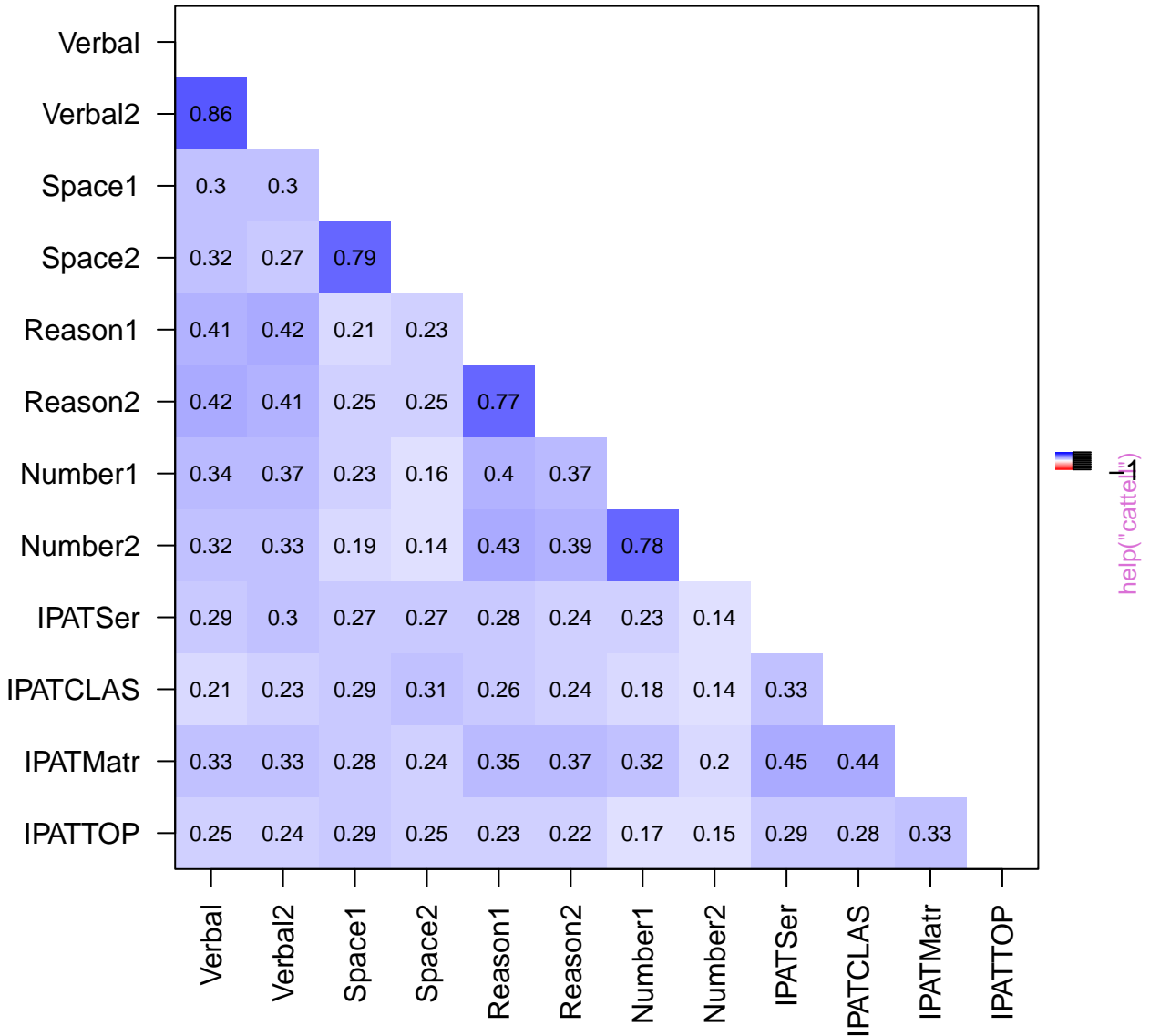

Circumplex Structure

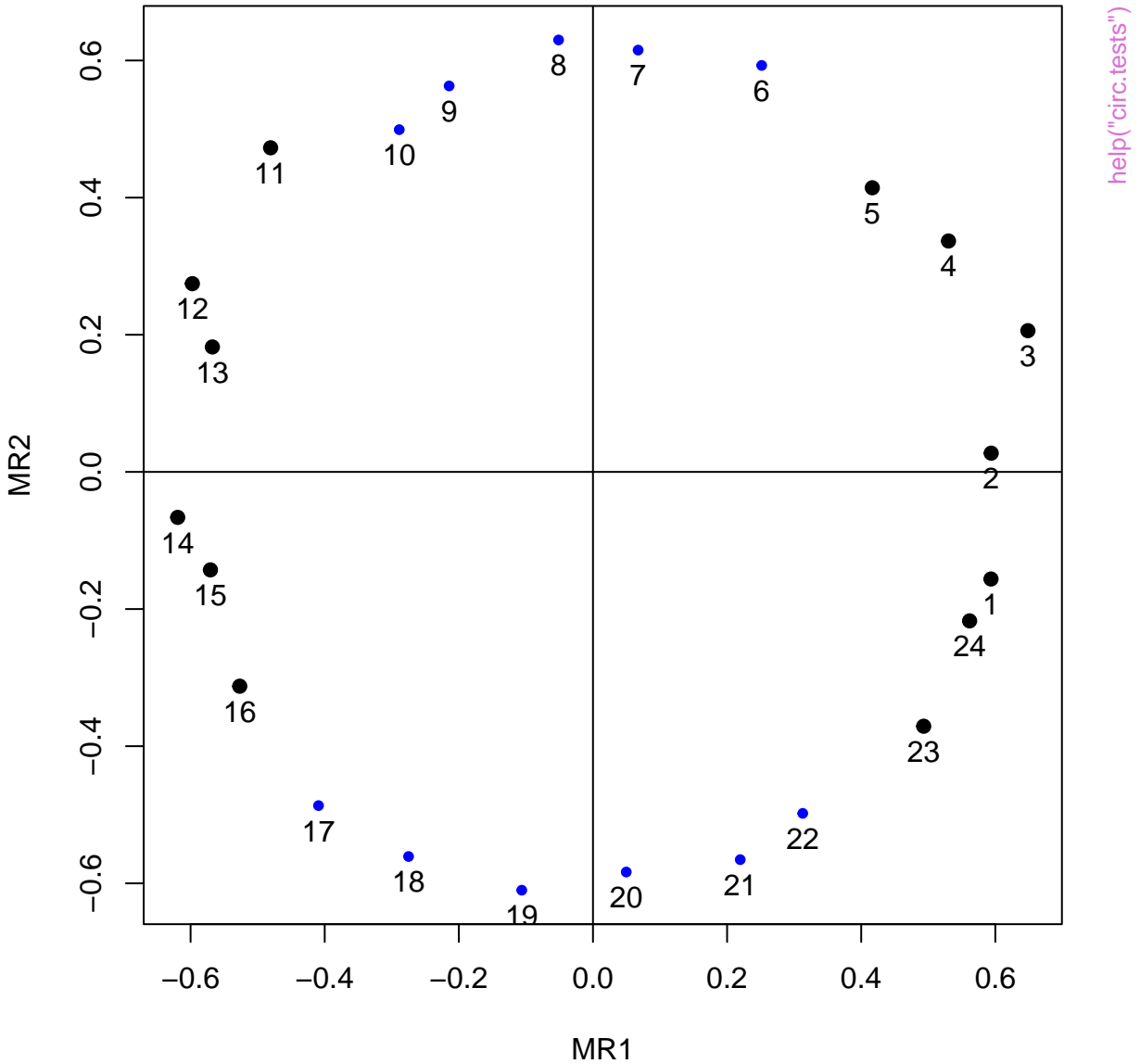

Simple Structure

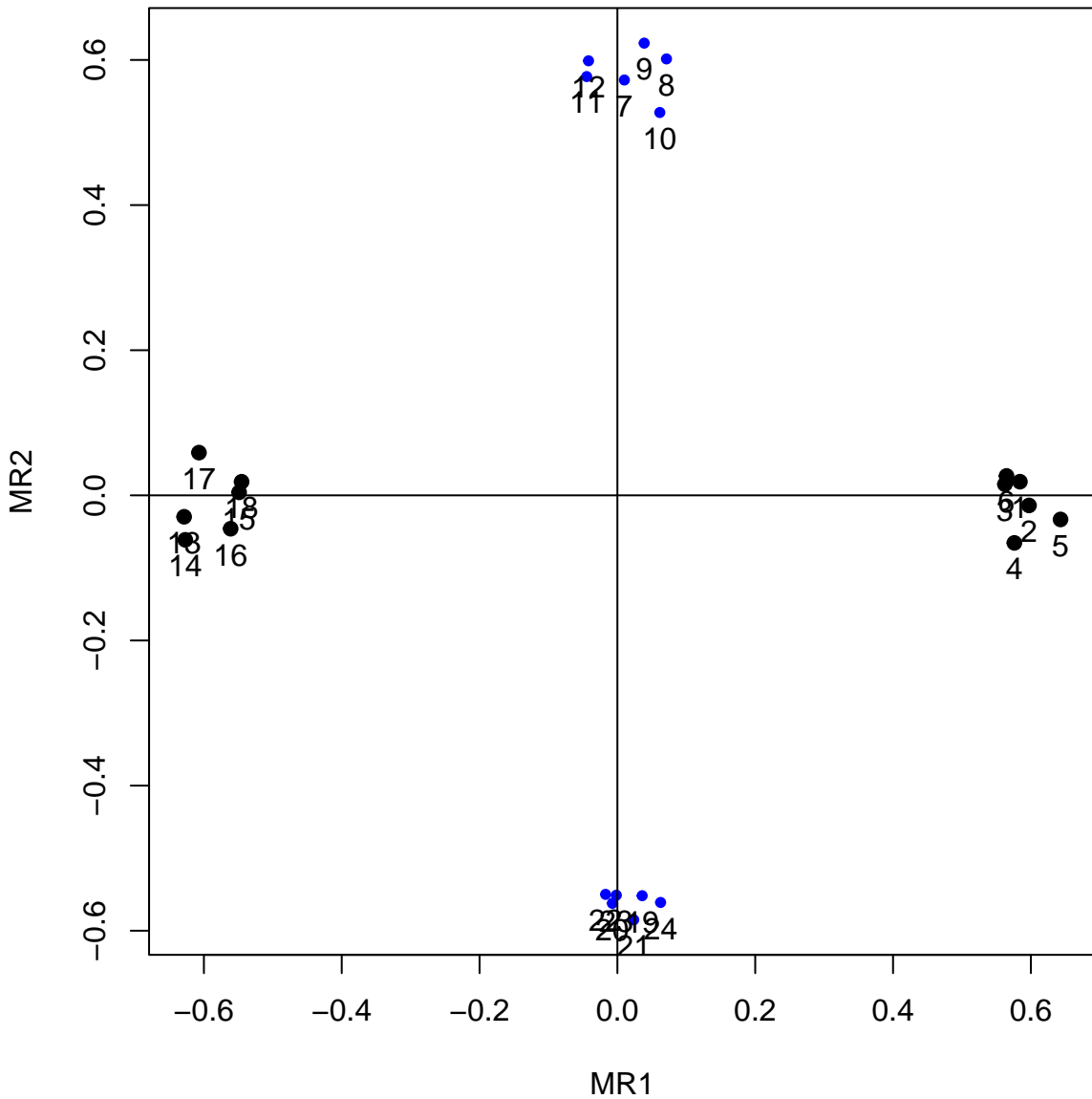

help("circ.tests")

ICLUST

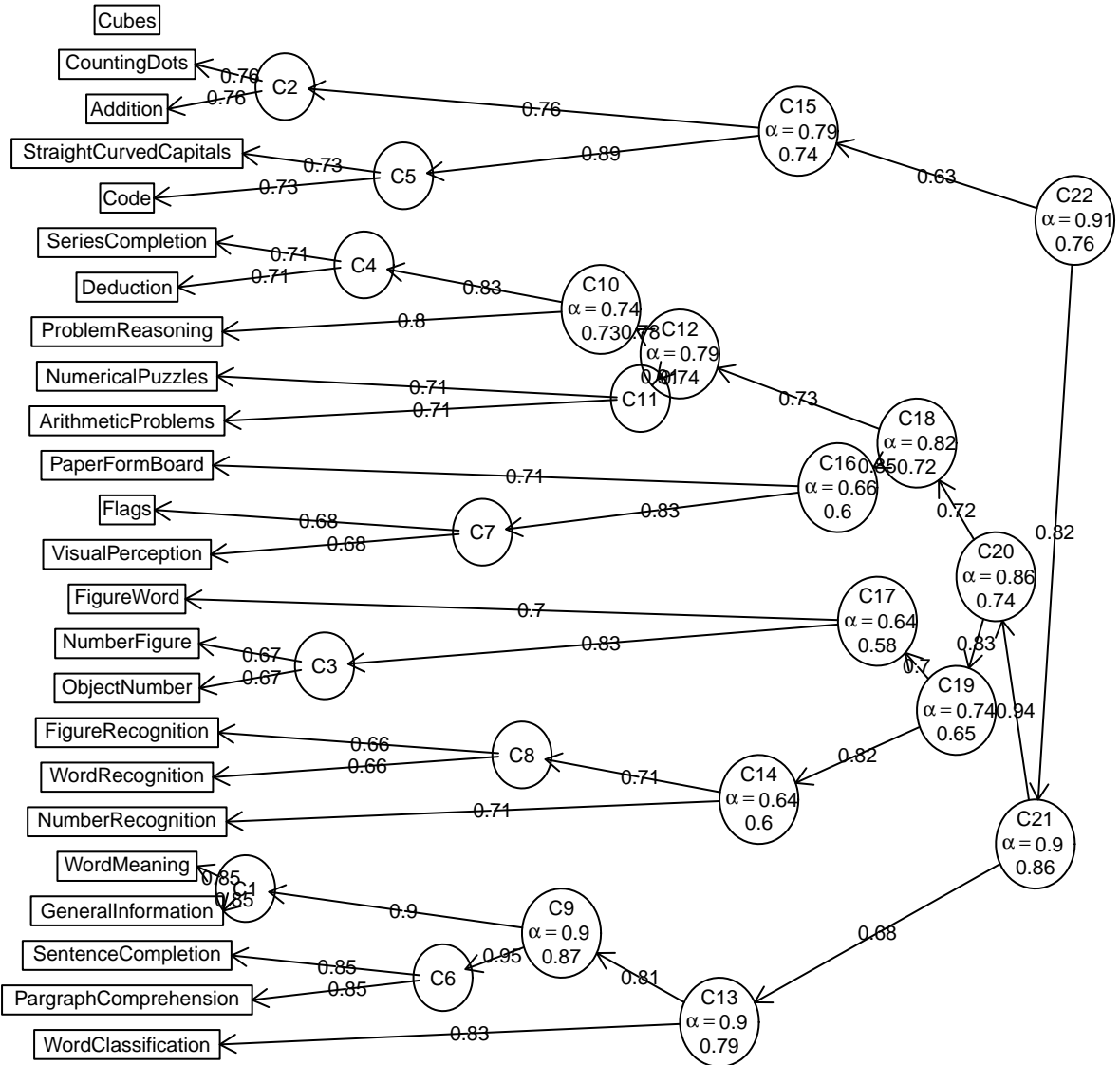

Factor Analysis

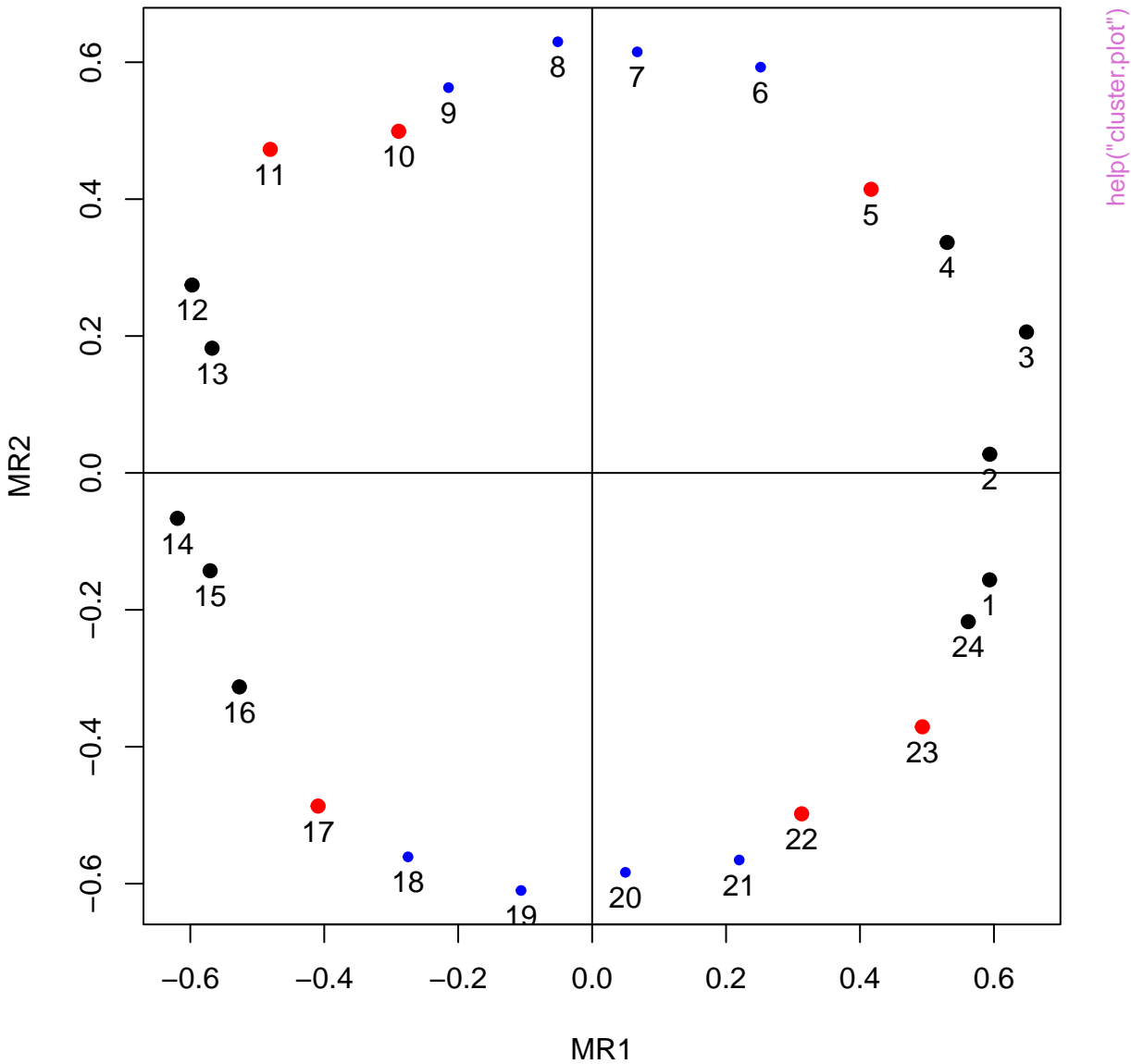

Factor Analysis

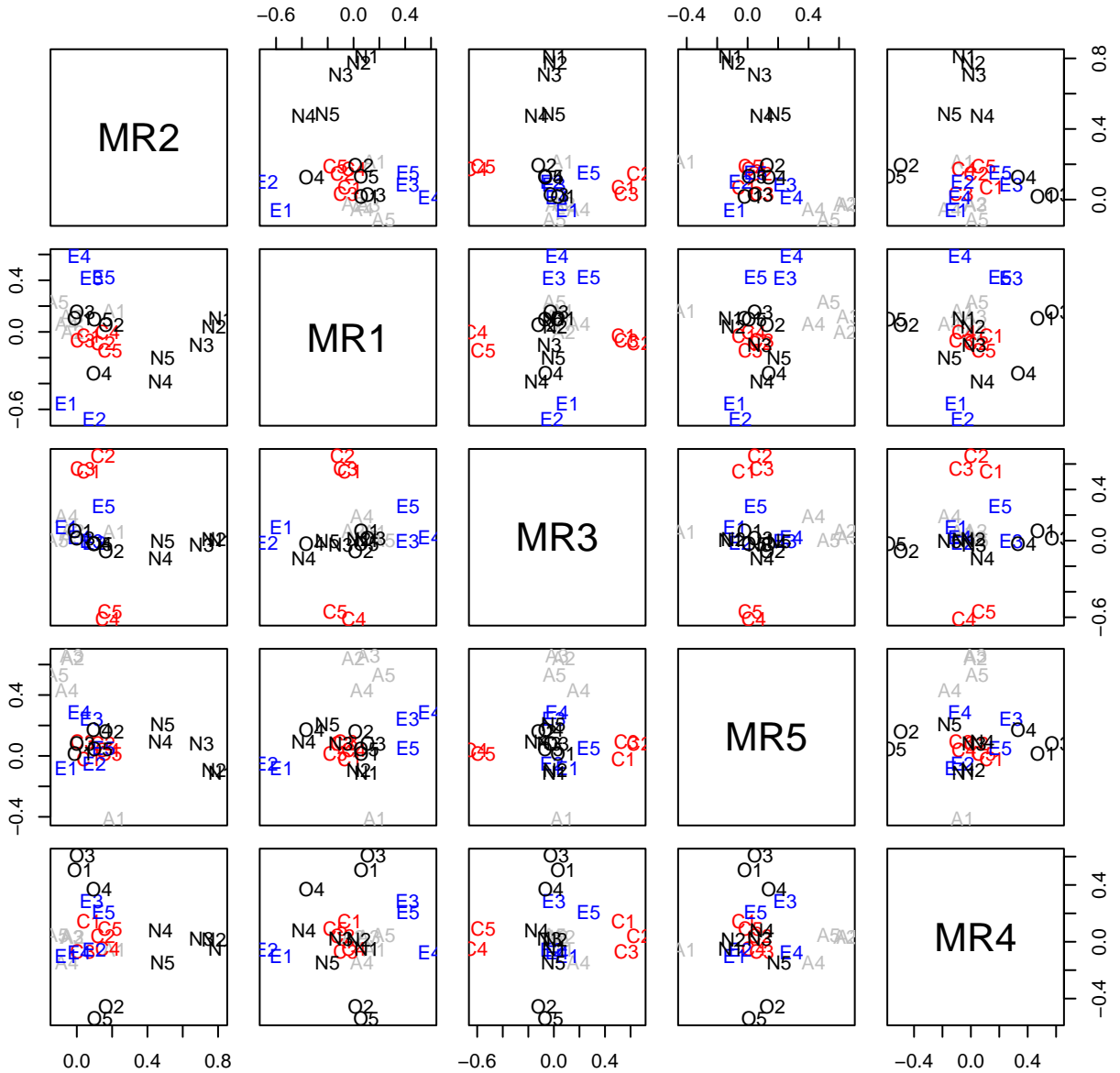

help("cluster.plot")

Factor Analysis

-0.6 -0.2 0.2 0.4 0.6

MR2

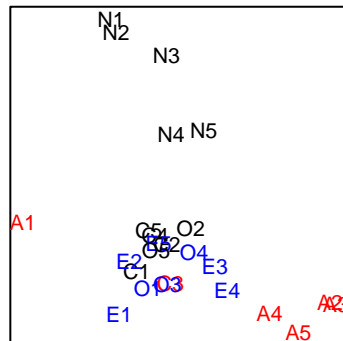
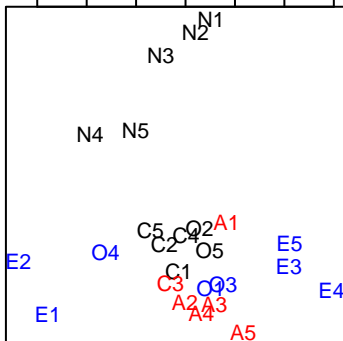

help("cluster.plot")

MR1

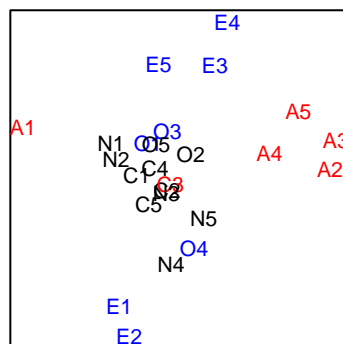
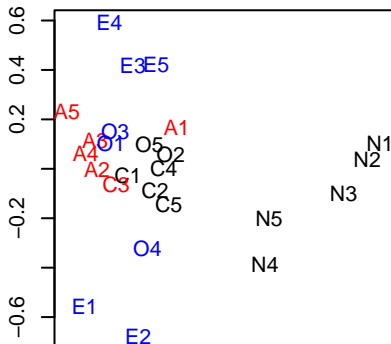

MR5

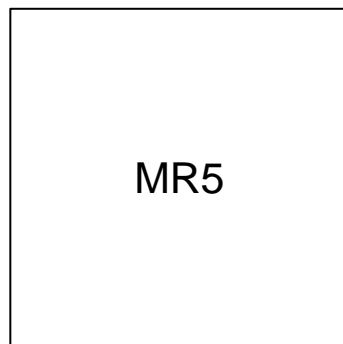
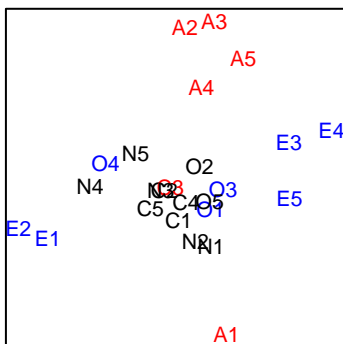
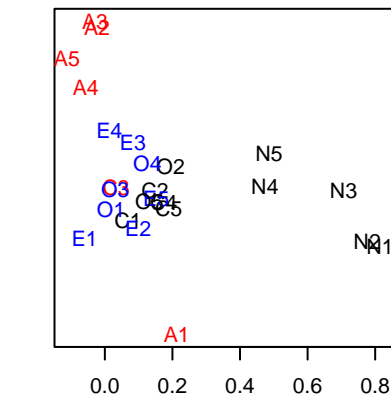

0.0 0.2 0.4 0.6 0.8

-0.4 0.0 0.2 0.4 0.6

-0.4 0.0 0.2 0.4 0.6

Four representations of effect size (d)

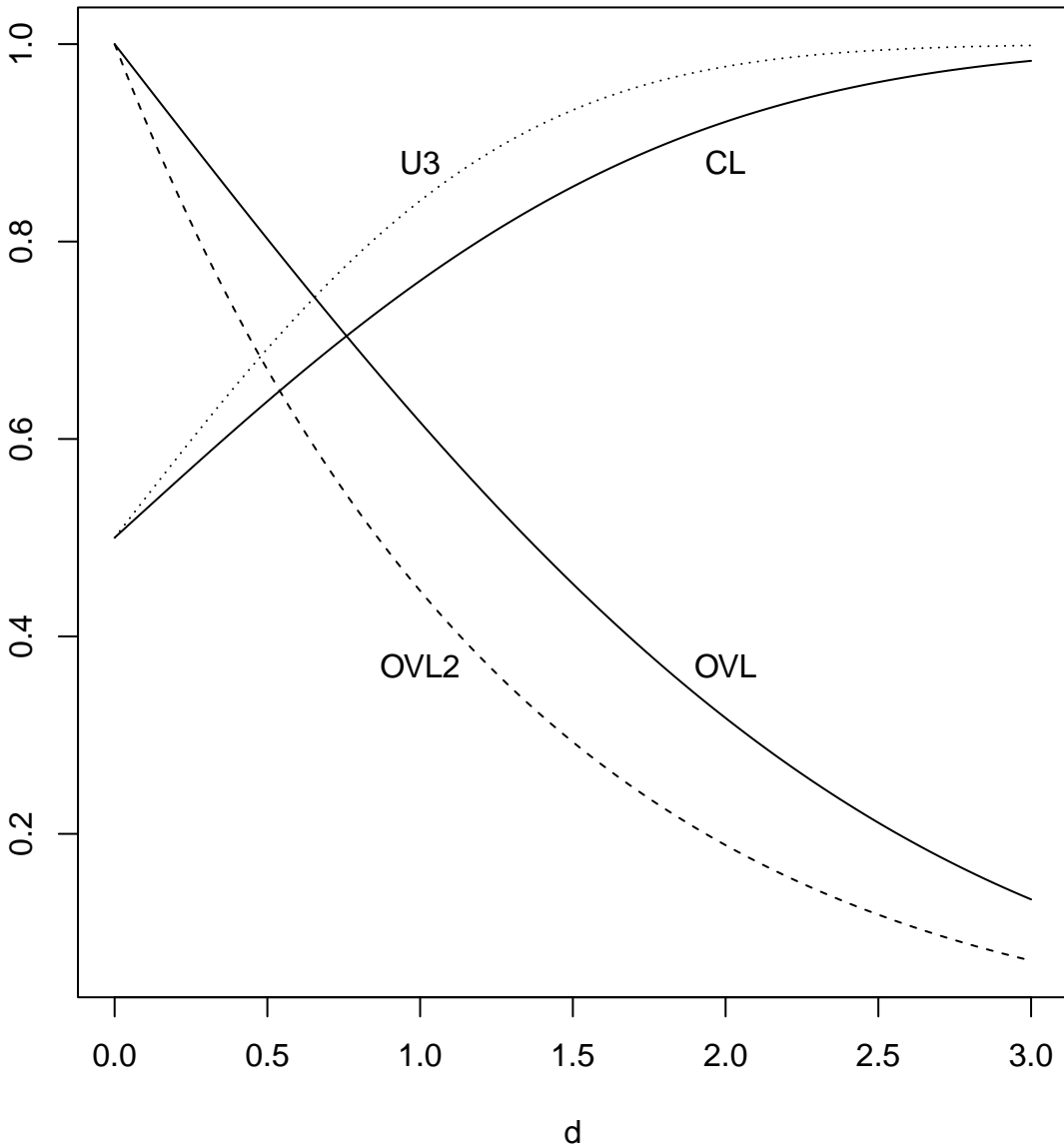

help("cohen.d")

Upper and lower confidence intervals of correlations

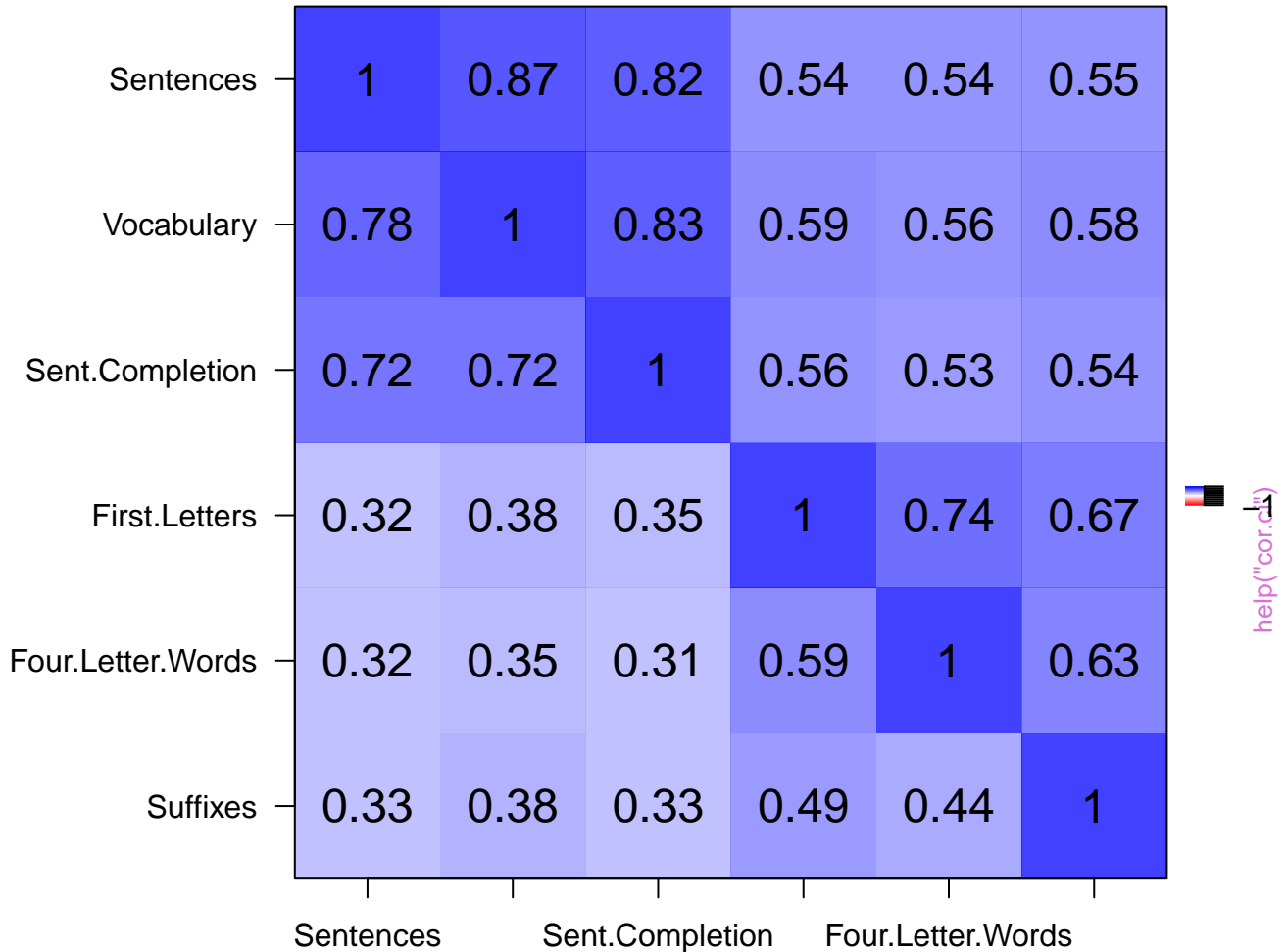

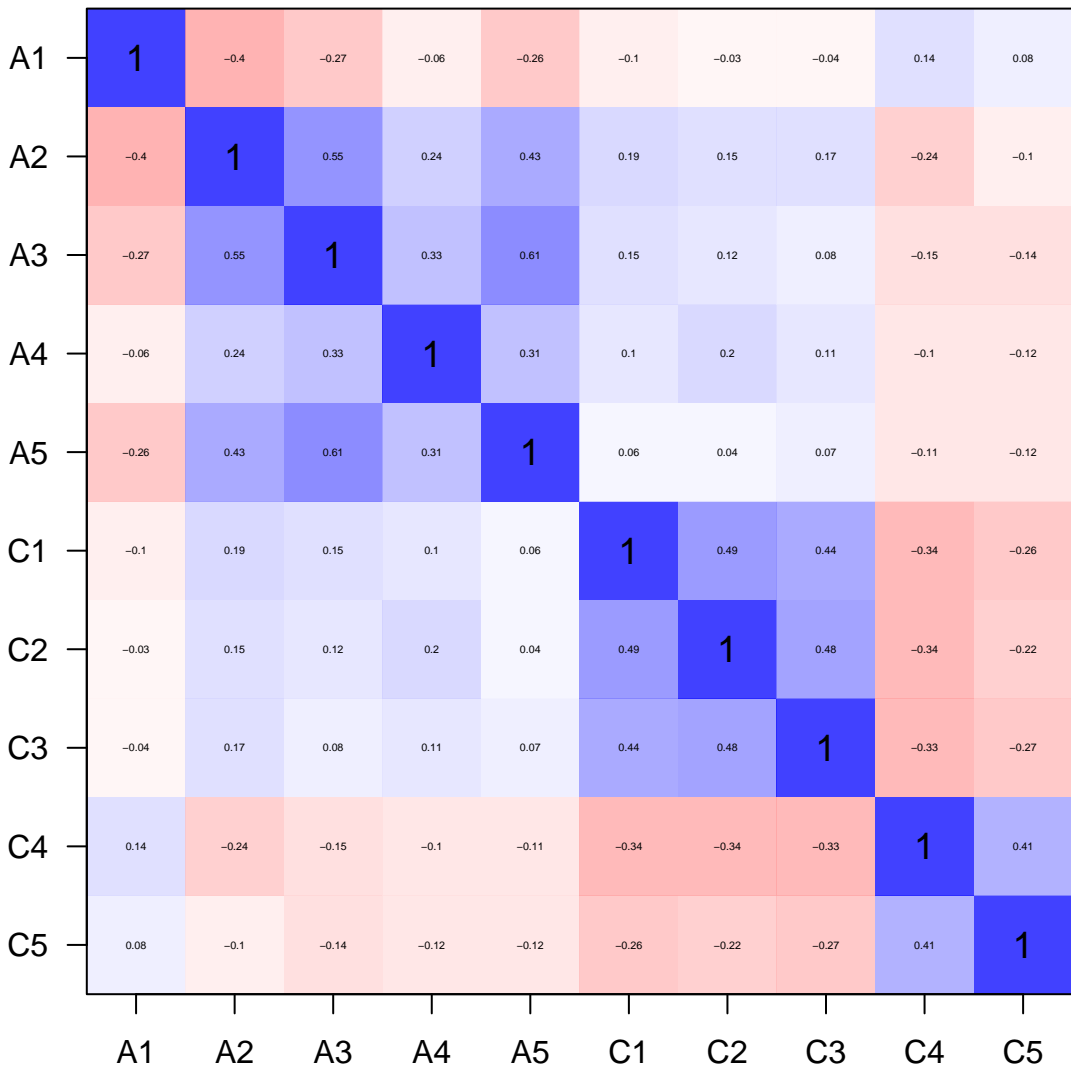

help("cor.c4")

correlation with overlapping scales

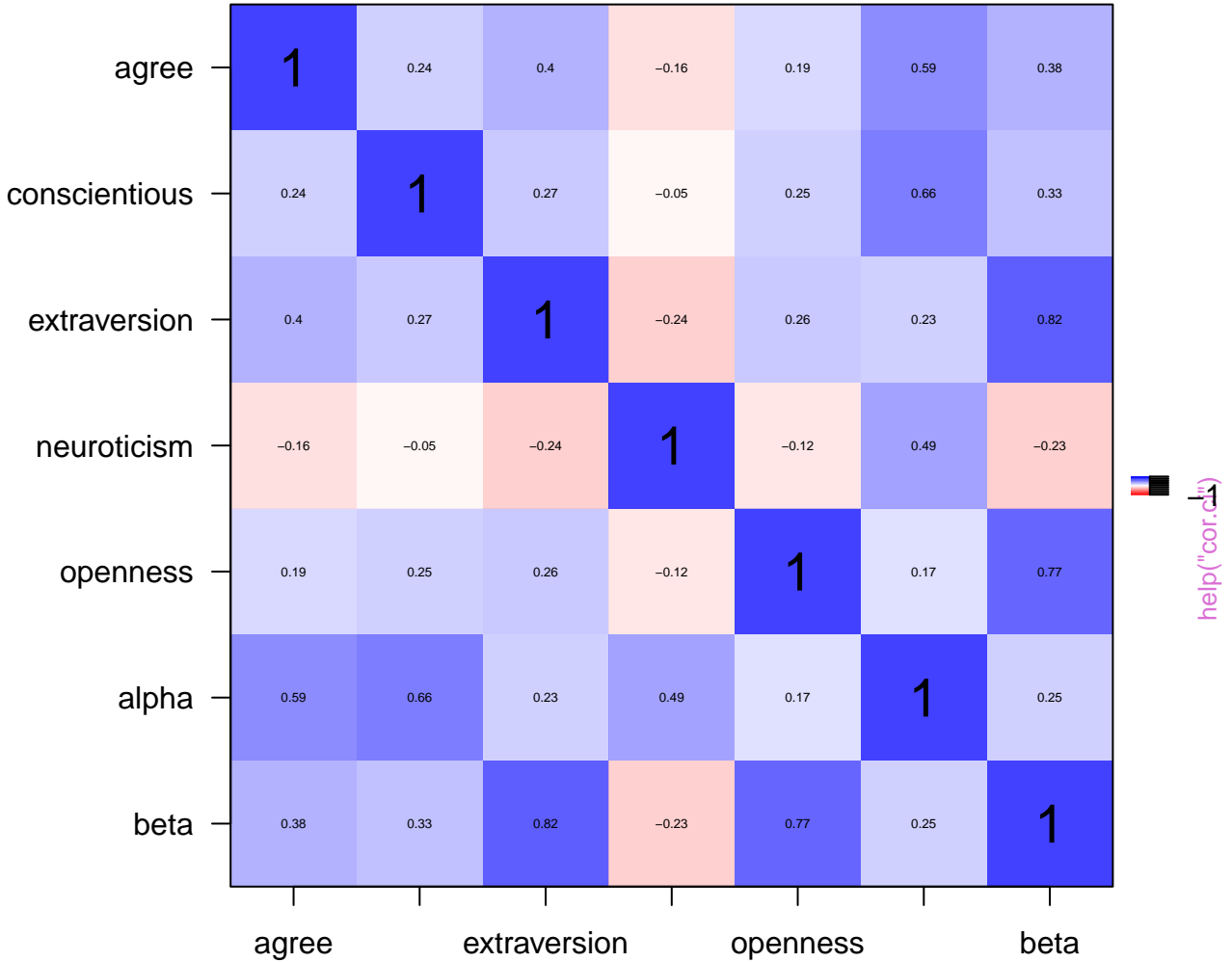

Correct for overlap

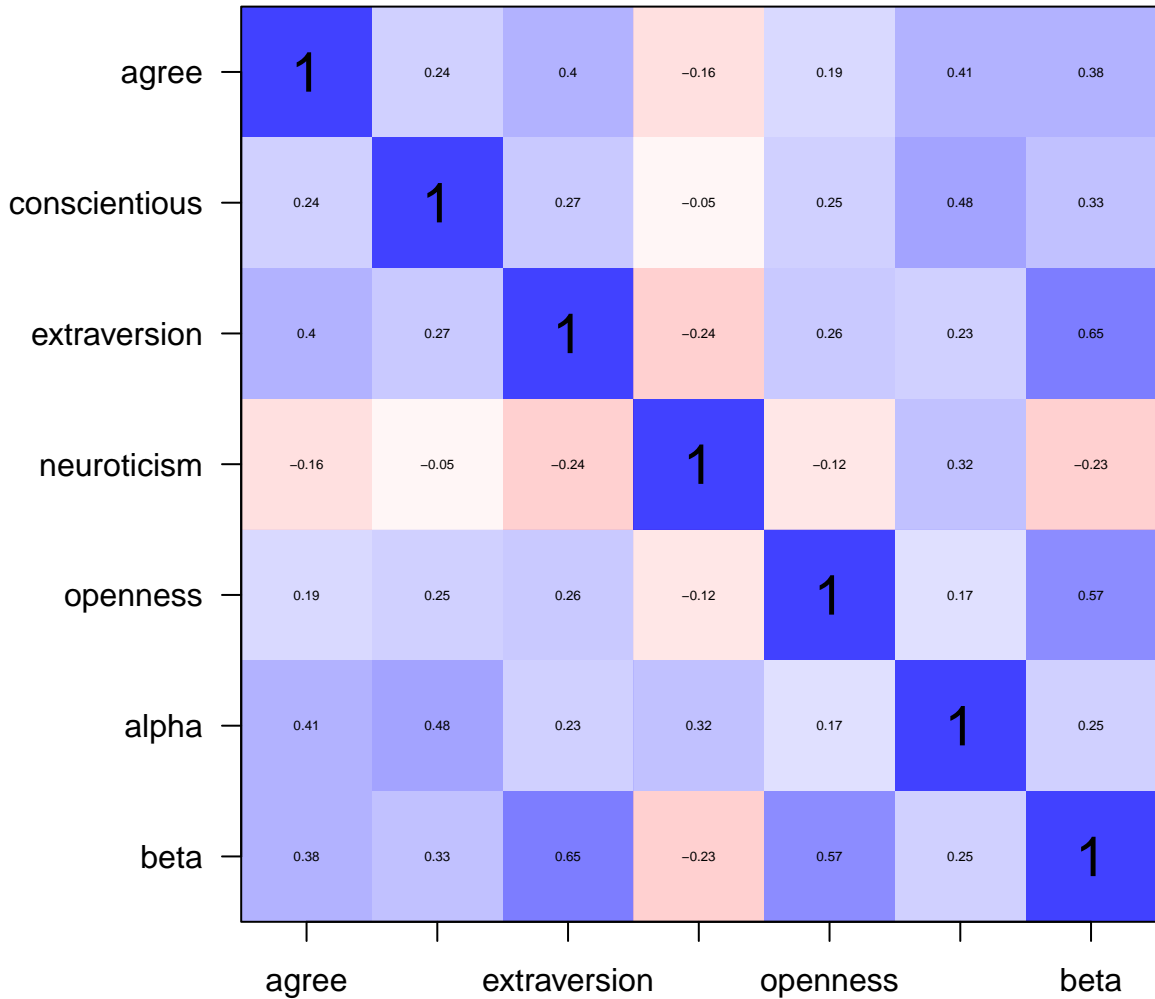

help("cor.4")

Upper and lower confidence intervals of correlations

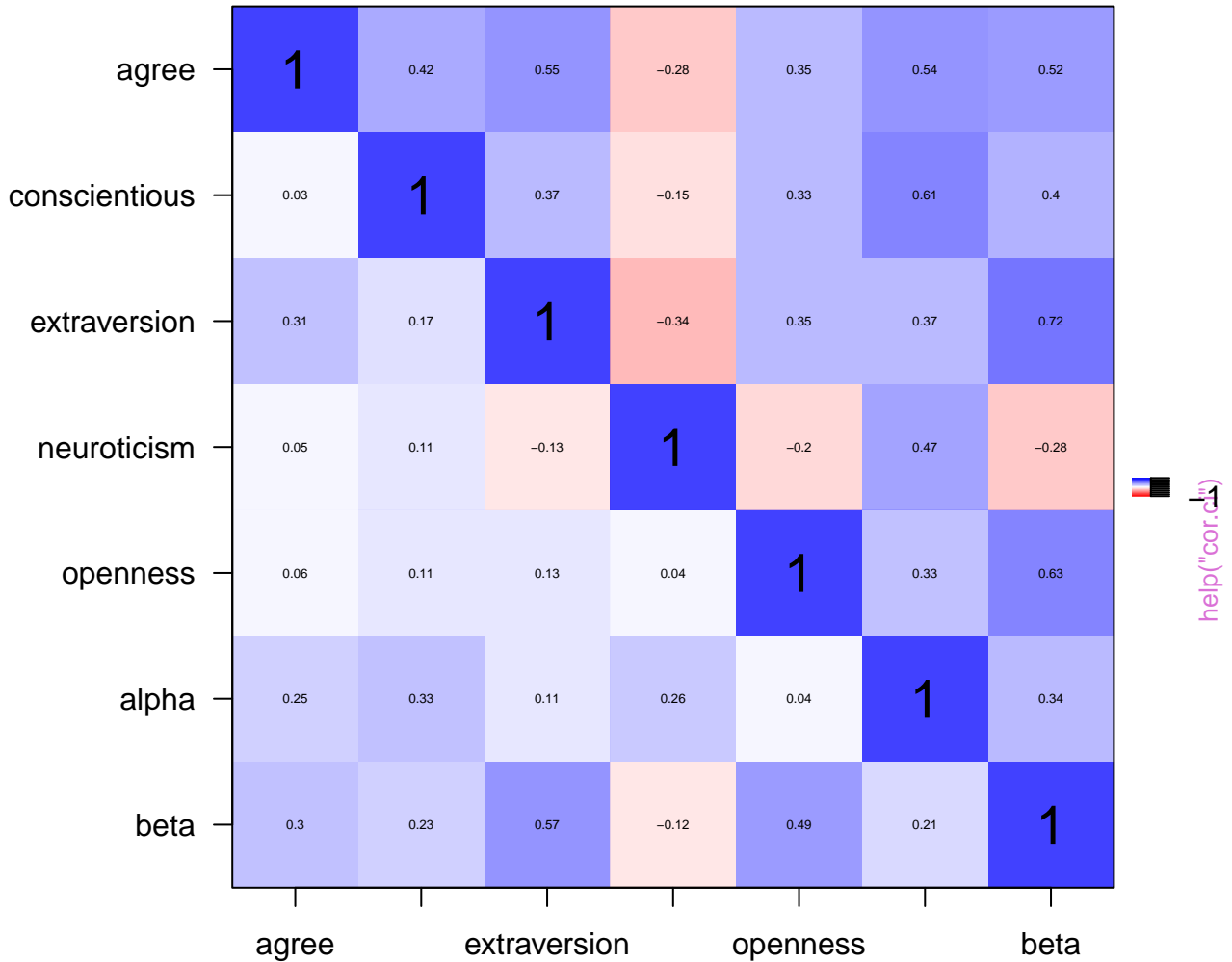

9 cognitive variables from Thurstone

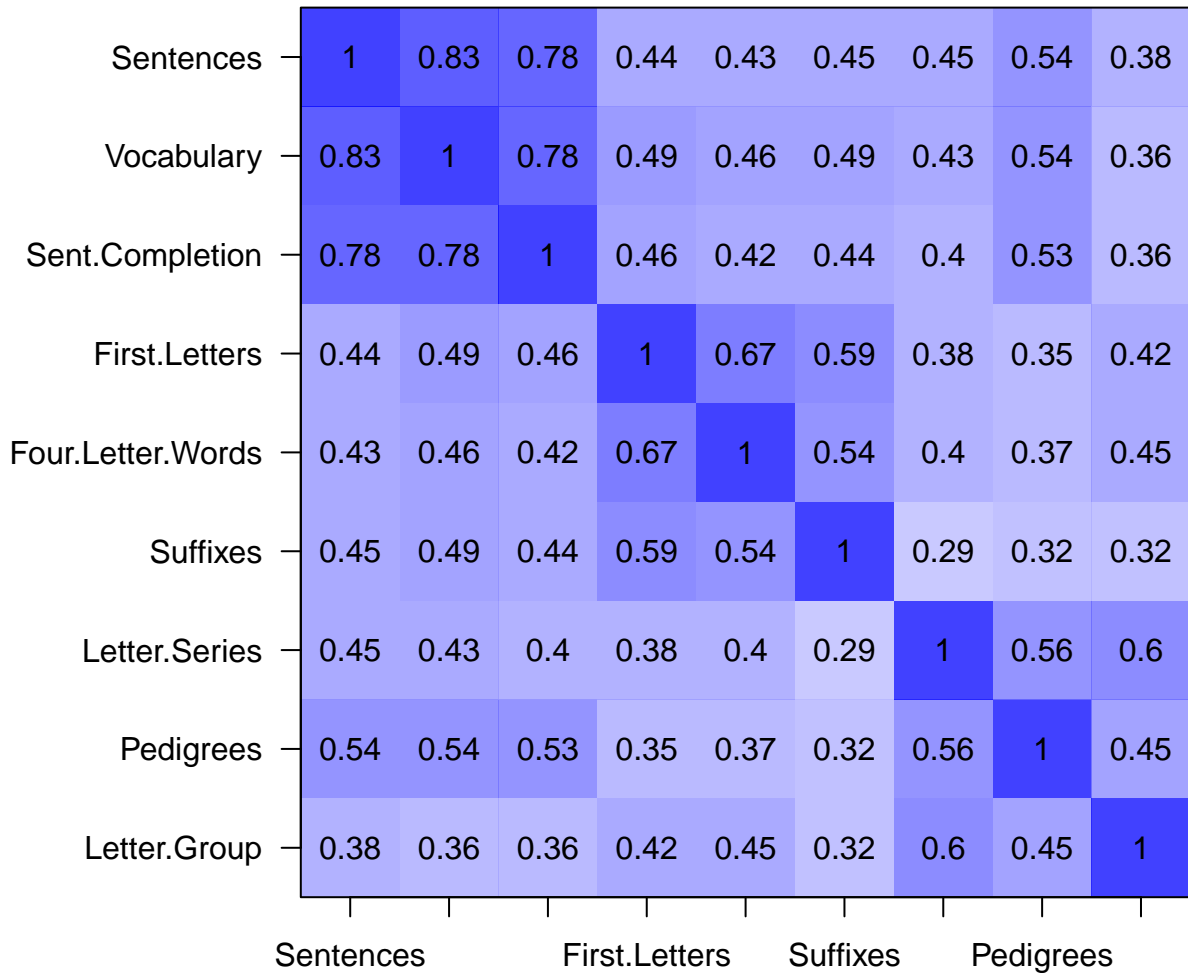

help("cor.plot")

9 cognitive variables from Thurstone

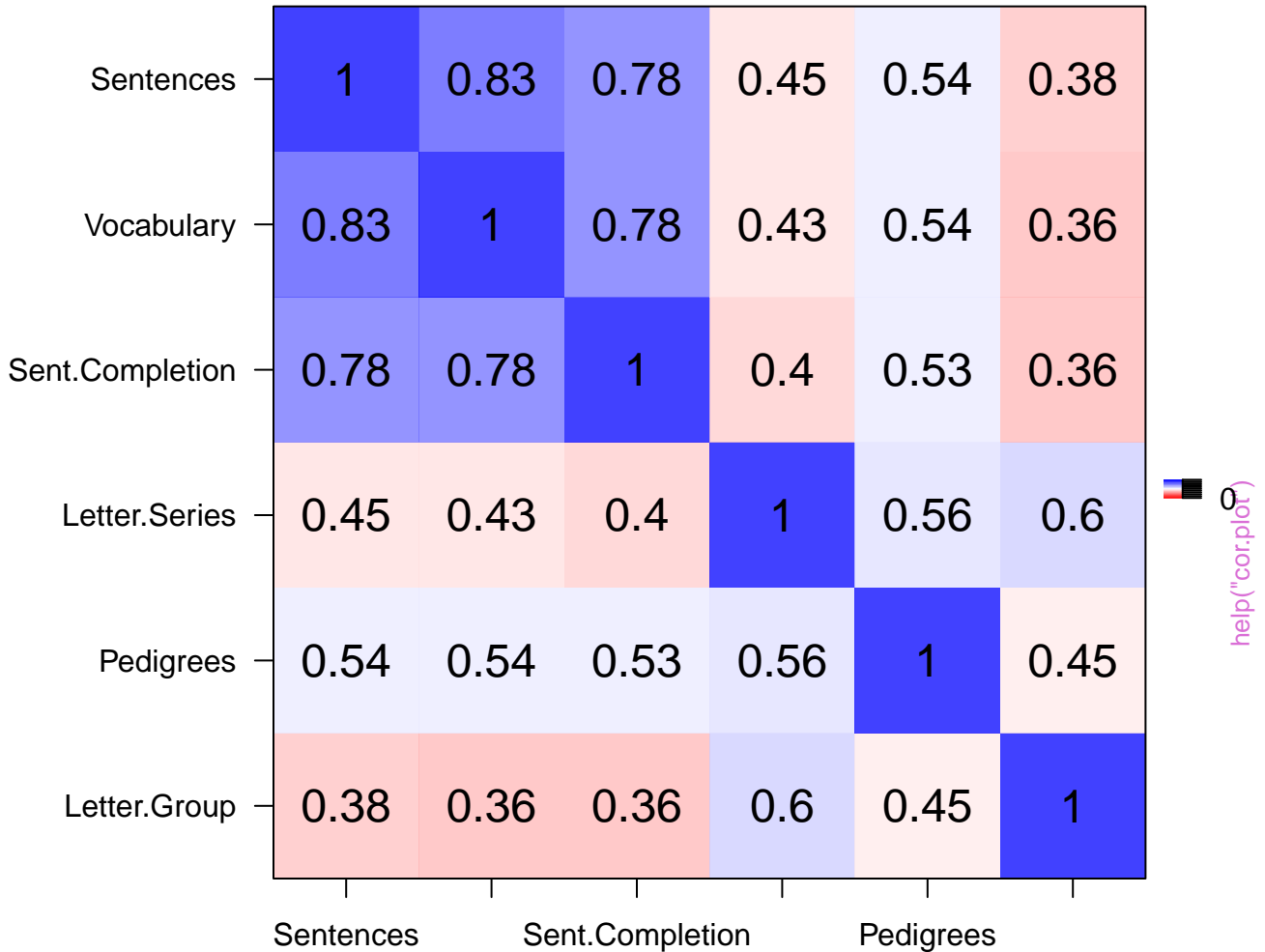

9 cognitive variables from Thurstone

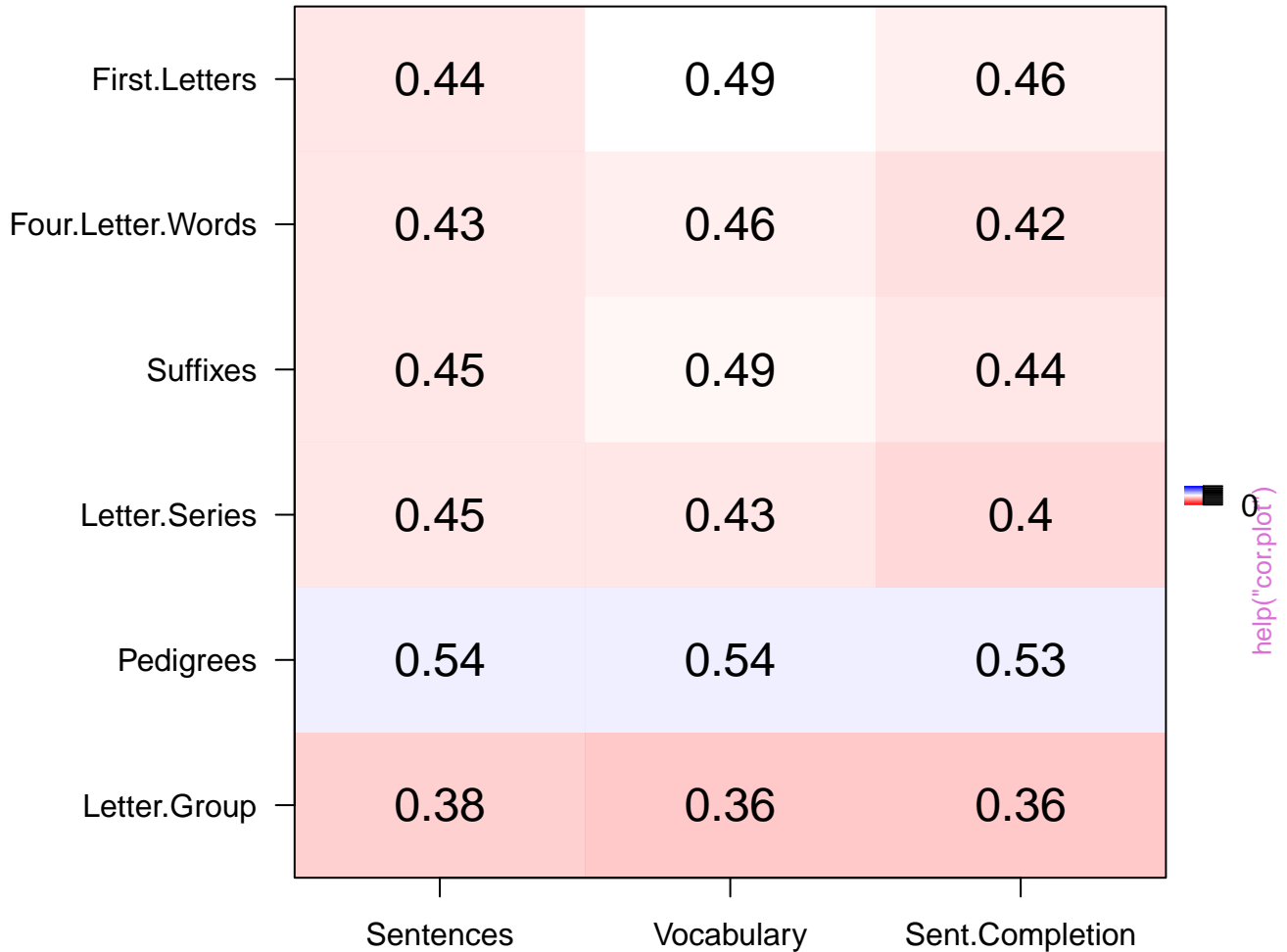

Correlation plot

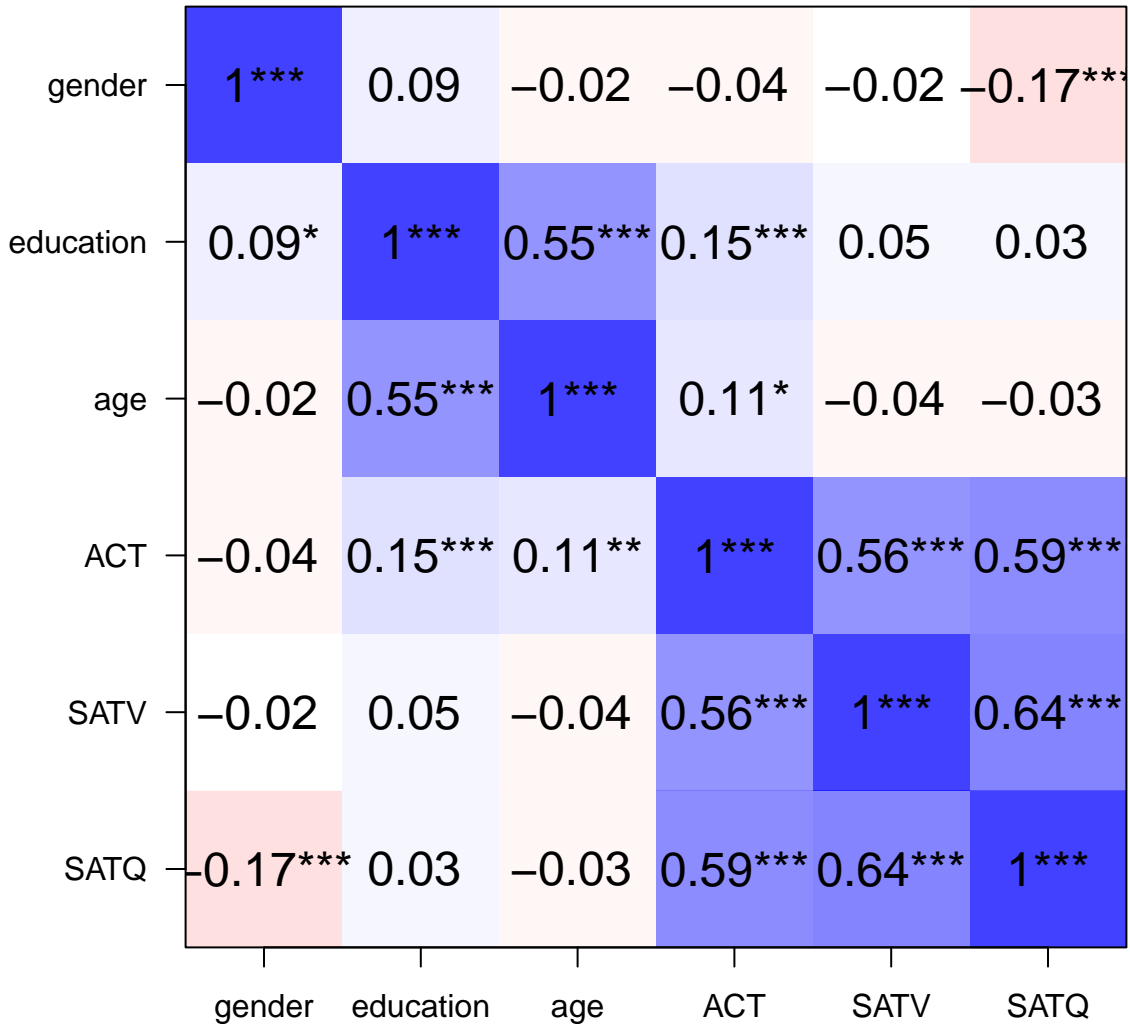

help("cor.plot")

Correlation plot with Holm corrected 'significance'

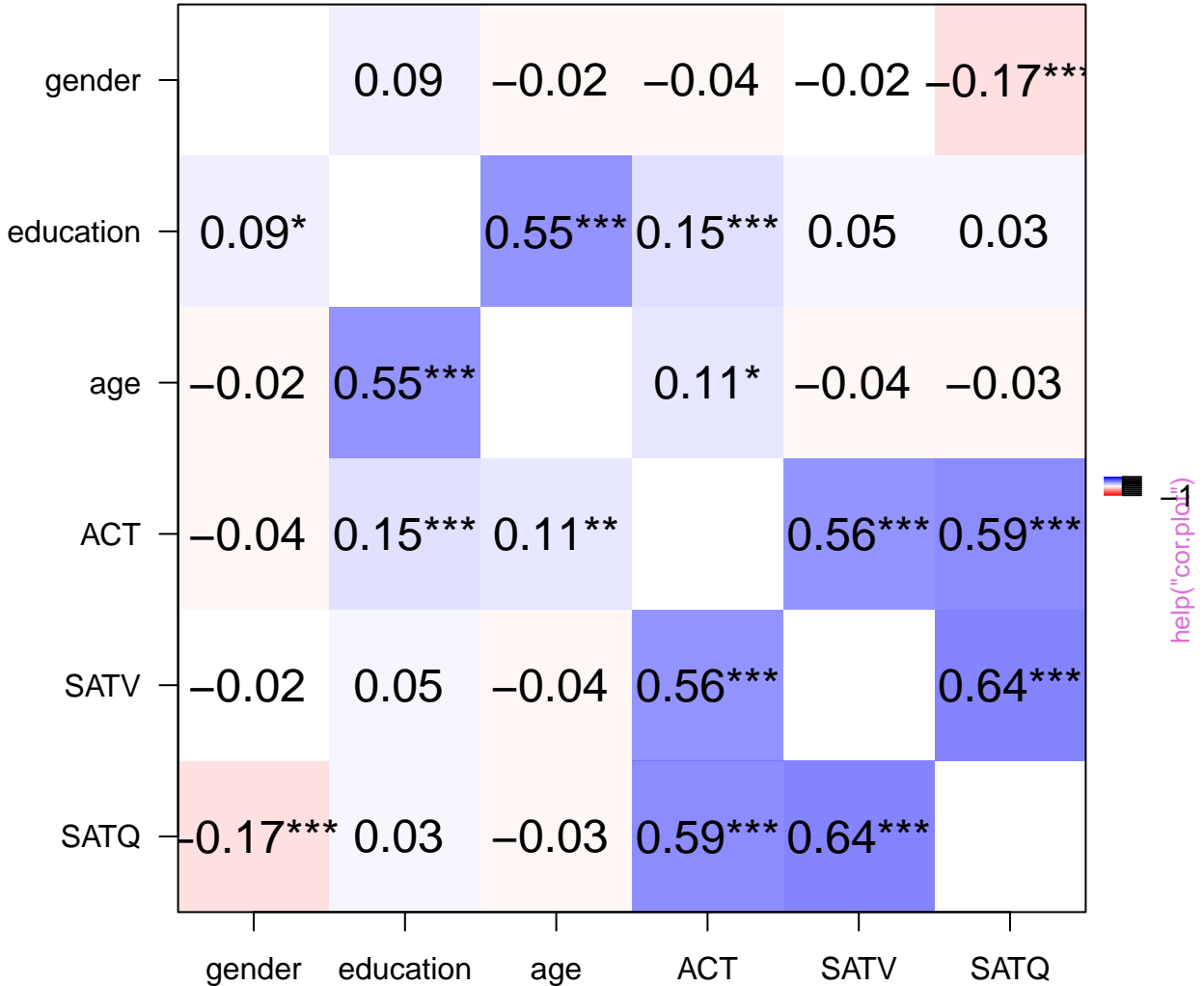

9 cognitive variables from Thurstone (sorted by factor load)

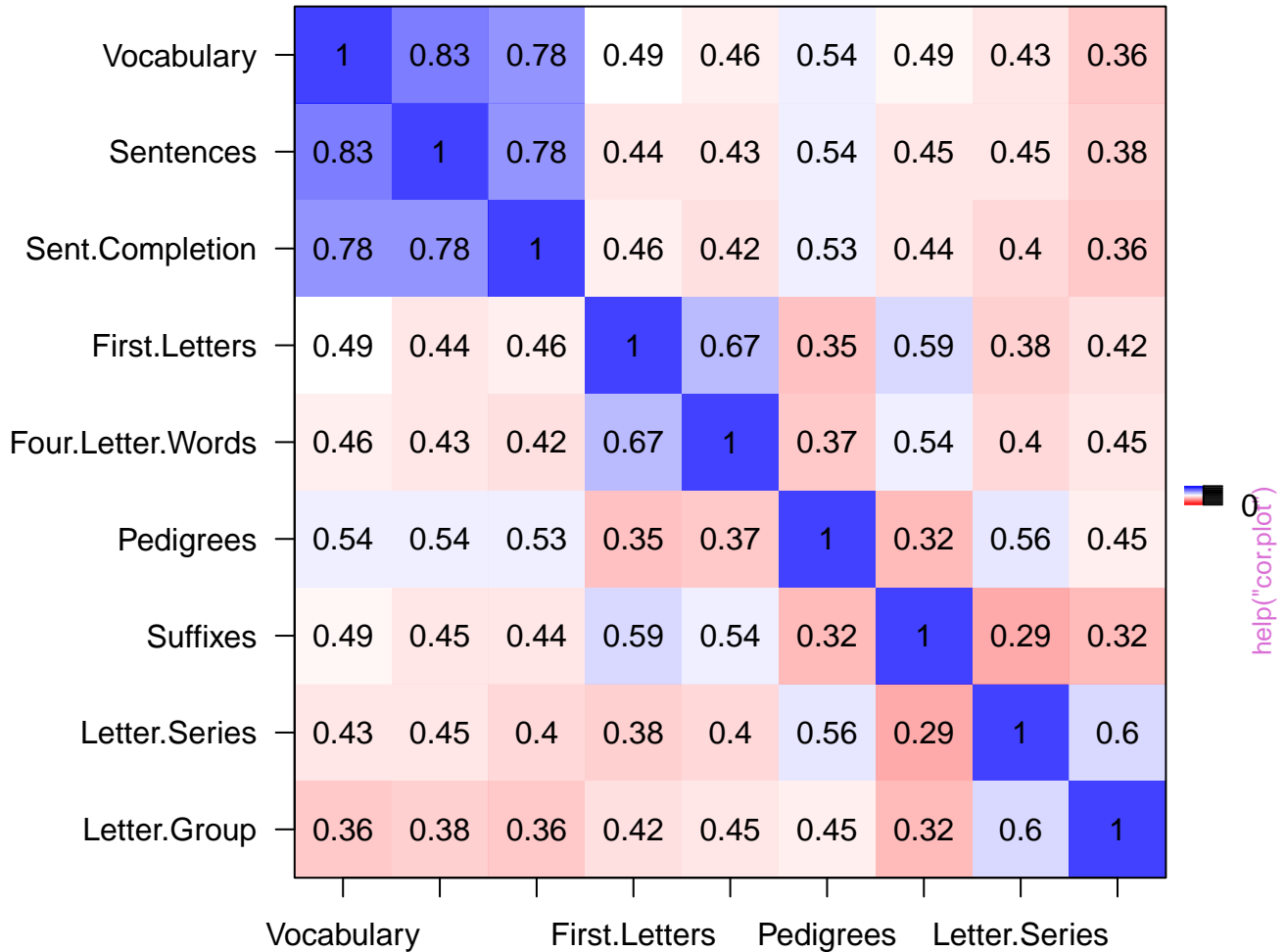

24 variables in a circumplex

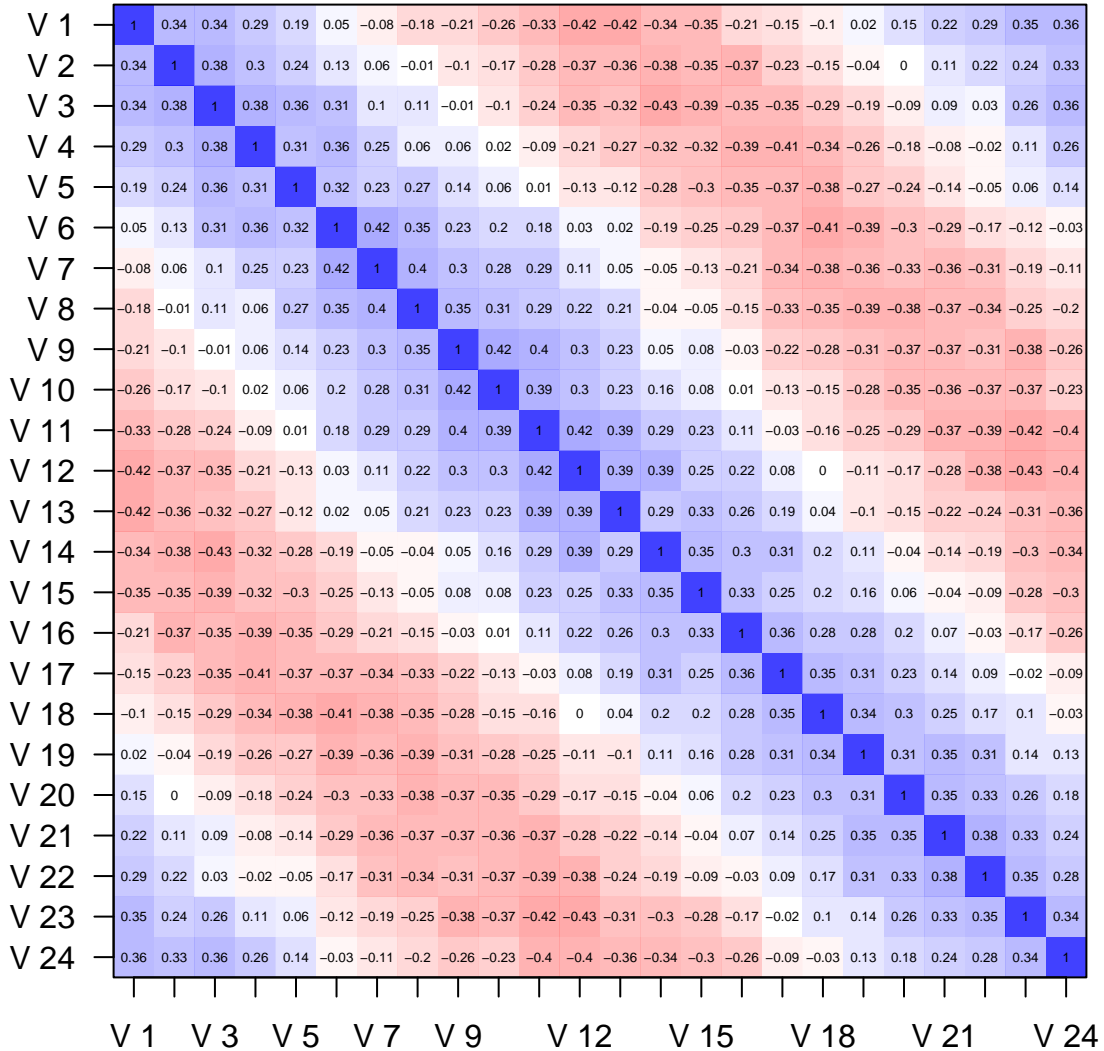

help("cor.plot")

Correlations scaled by probability values

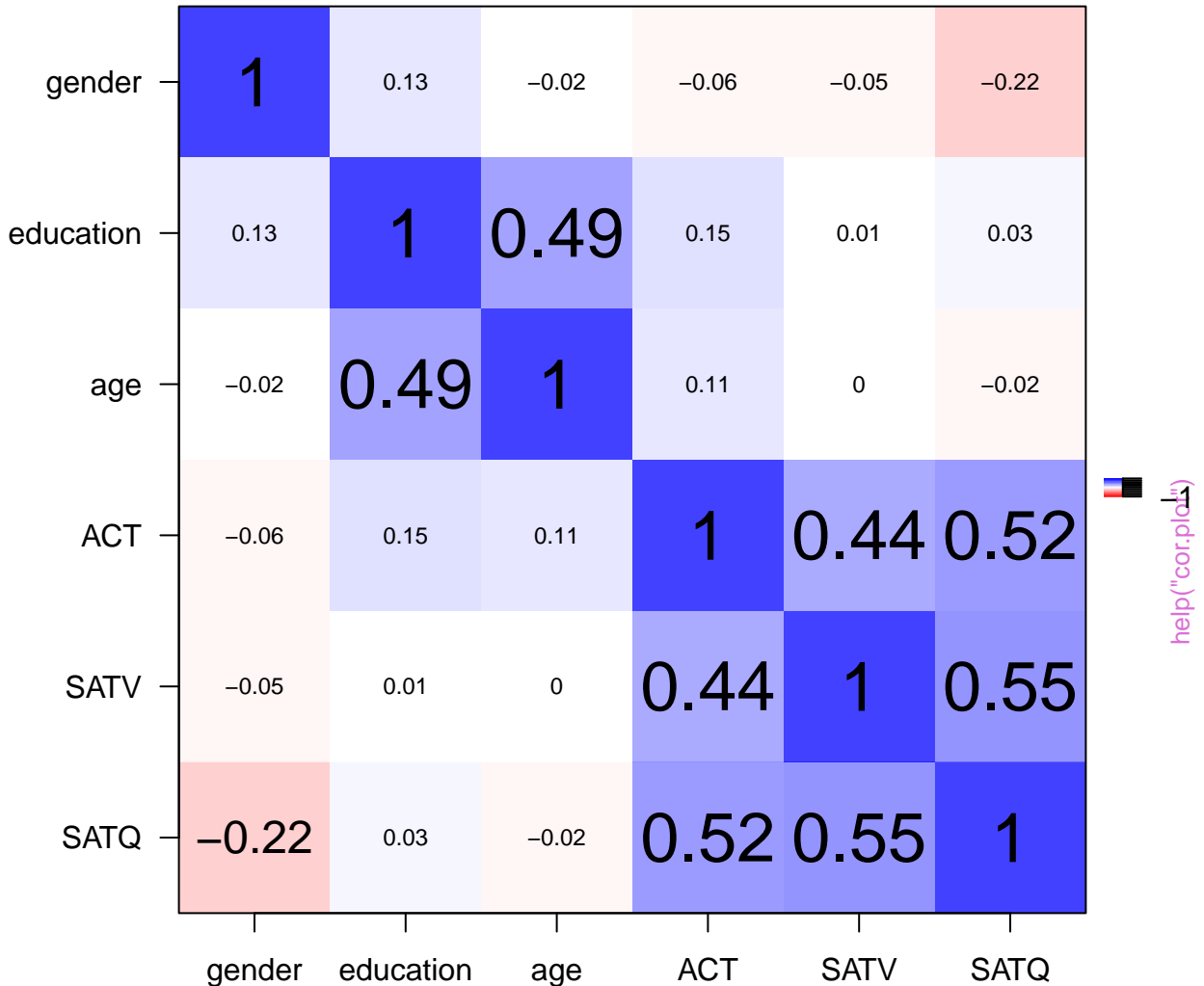

Upper and lower confidence intervals of correlations

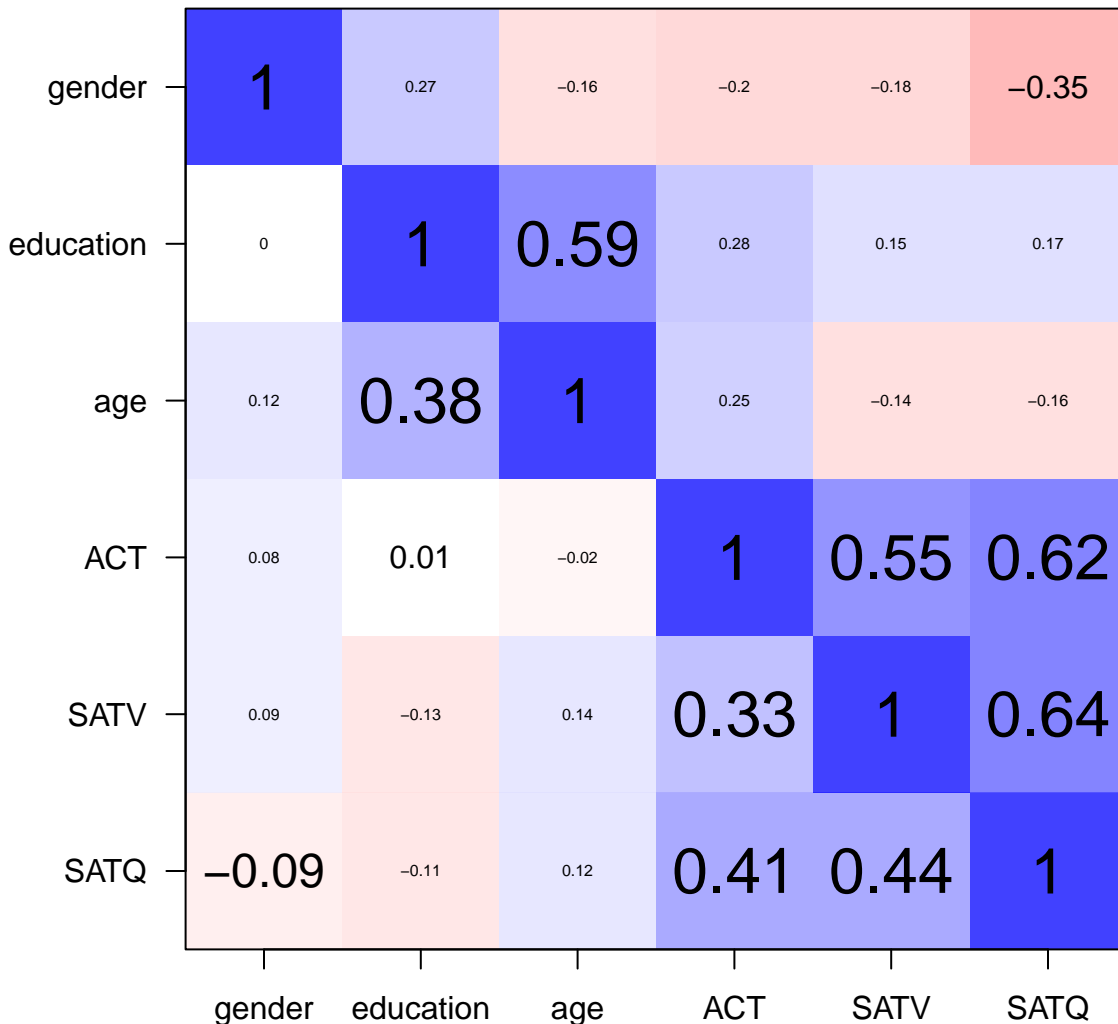

help("cor.plot")

Correlations scaled by probability values

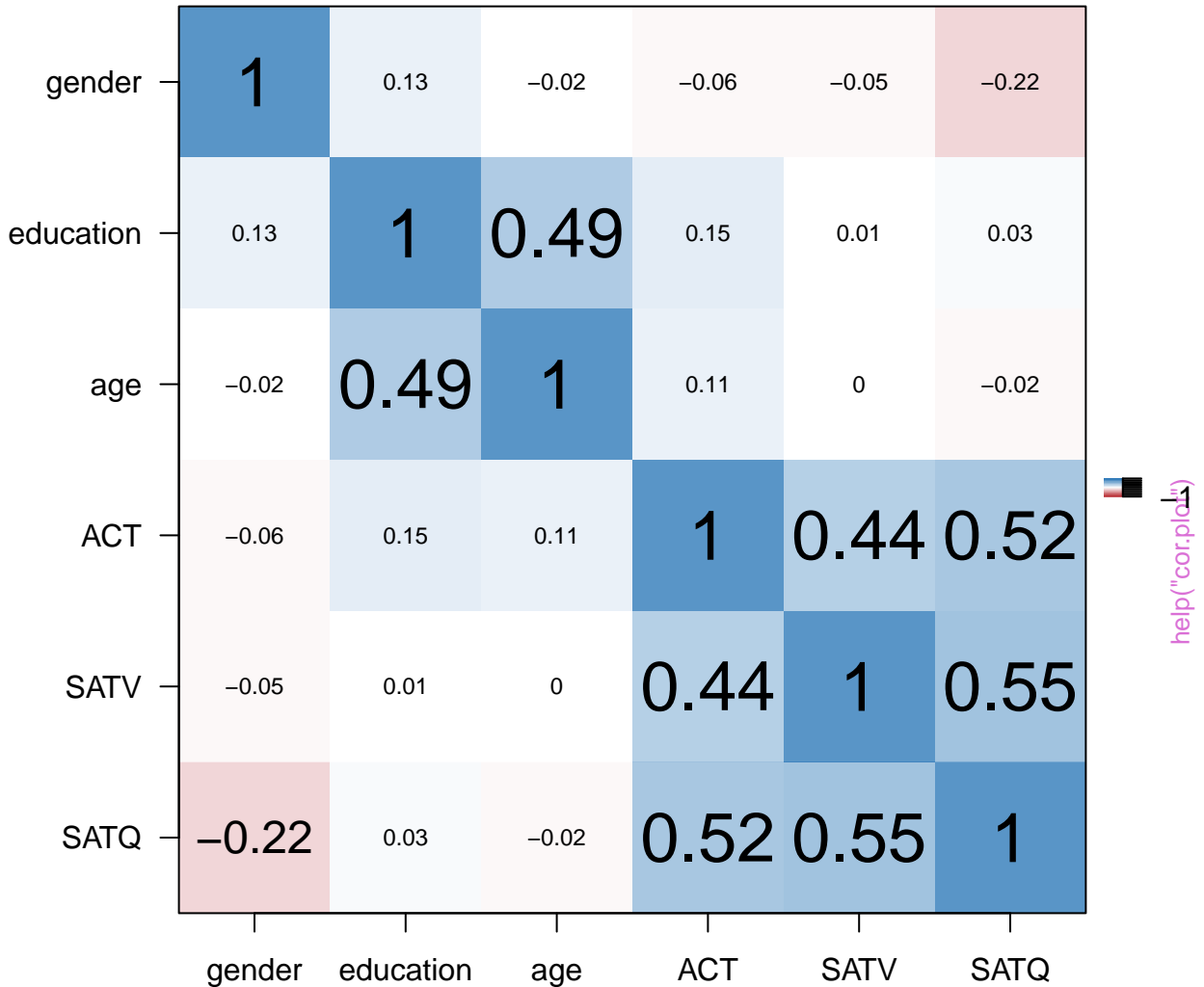

Upper and lower confidence intervals of correlations

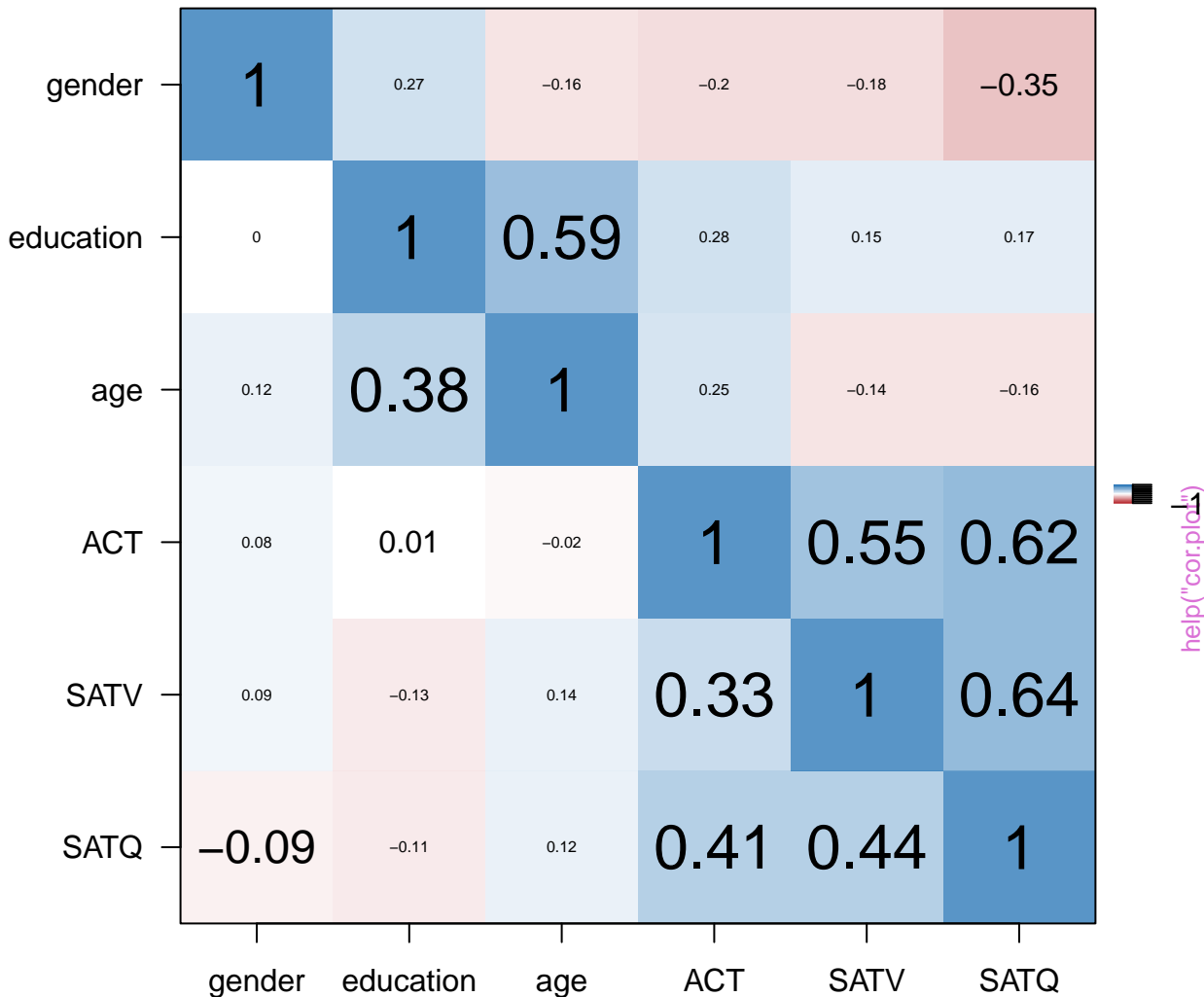

Correlation plot

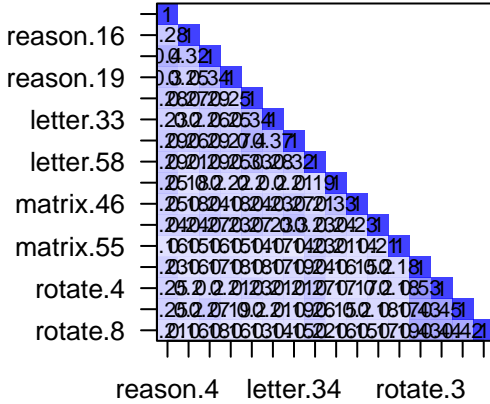

Factor Loadings plot

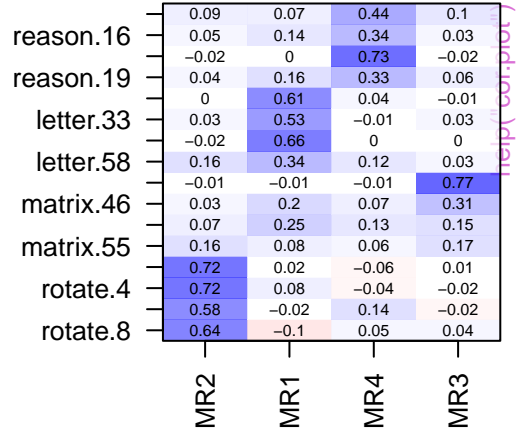

Omega

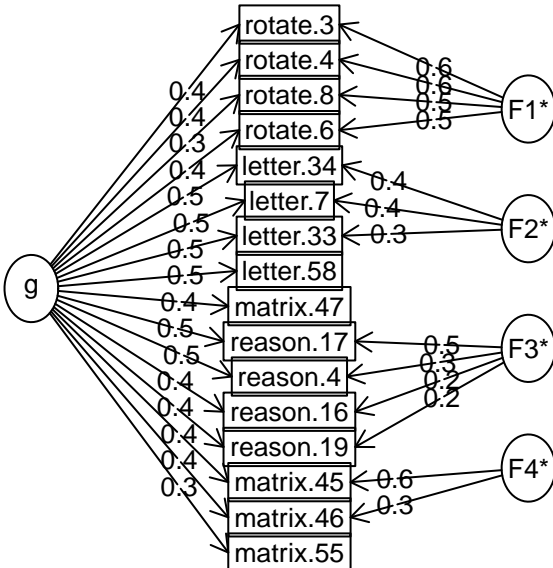

Omega plot

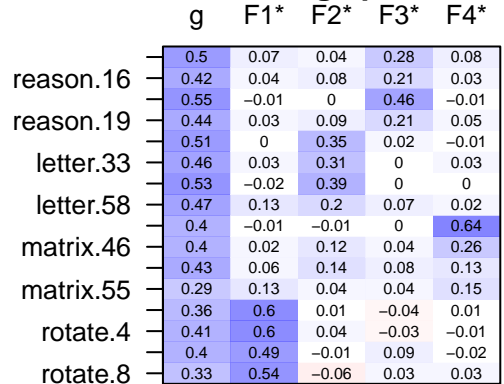

Holm adjusted confidence intervals

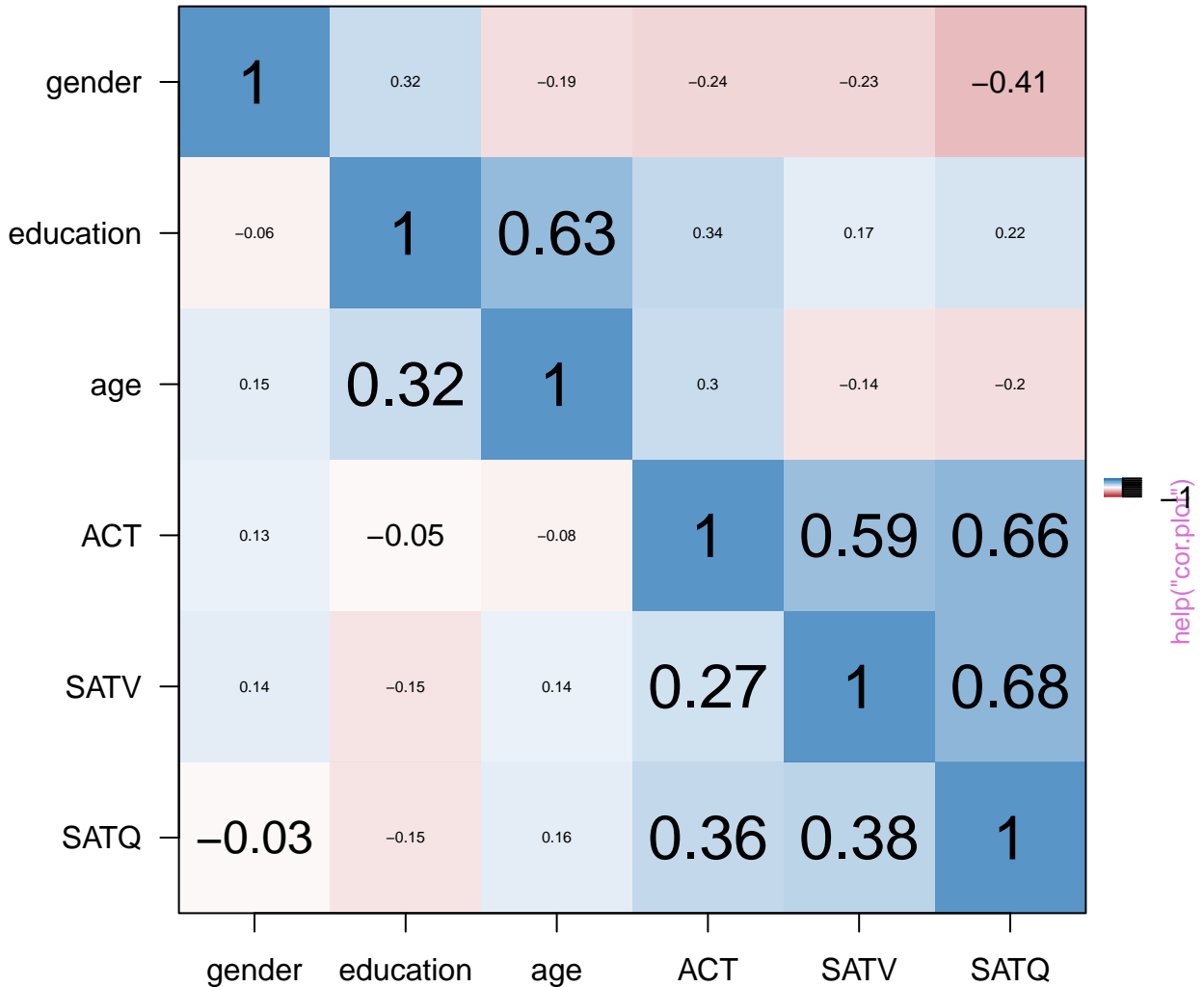

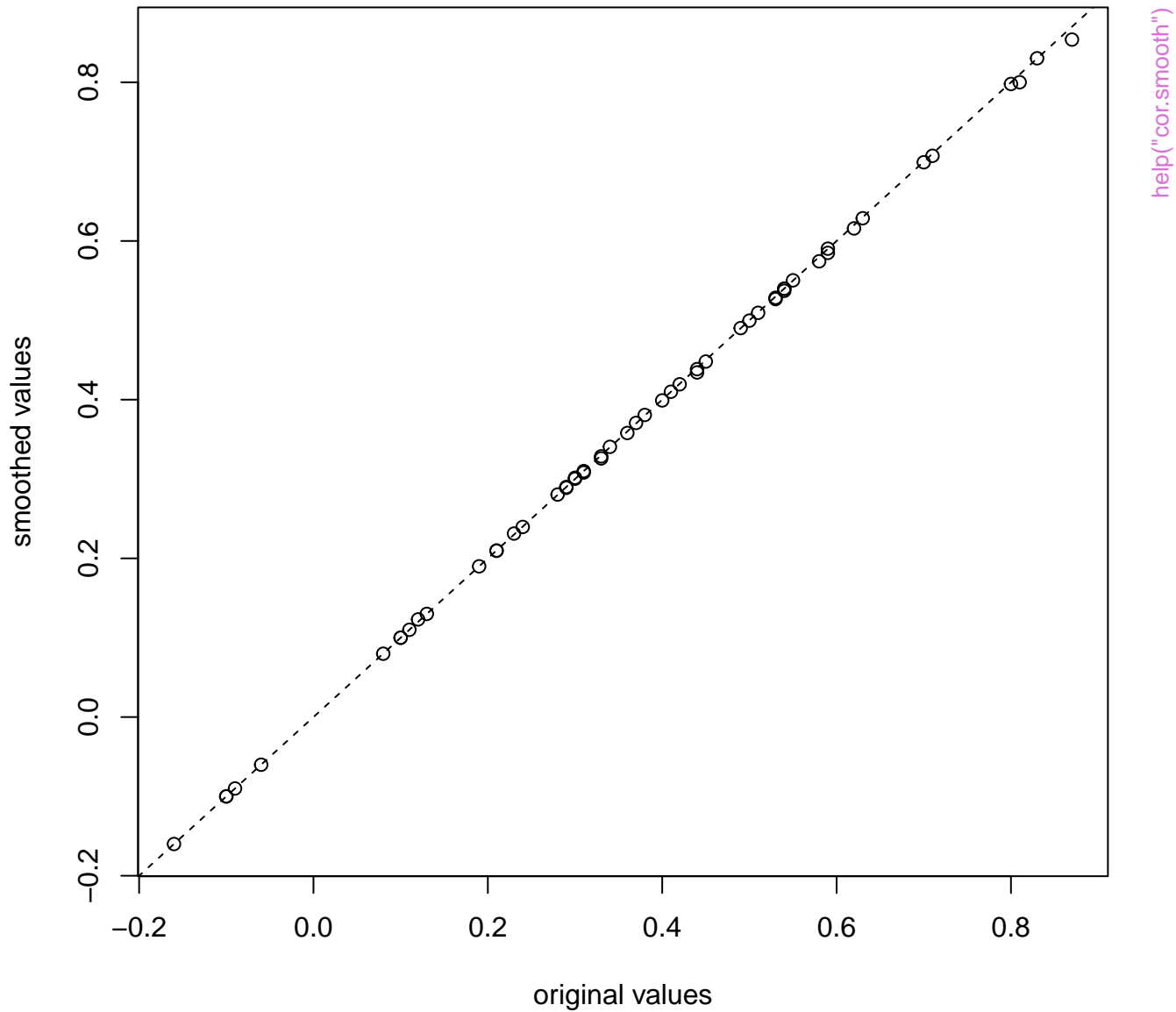

weighted versus unweighted correlations

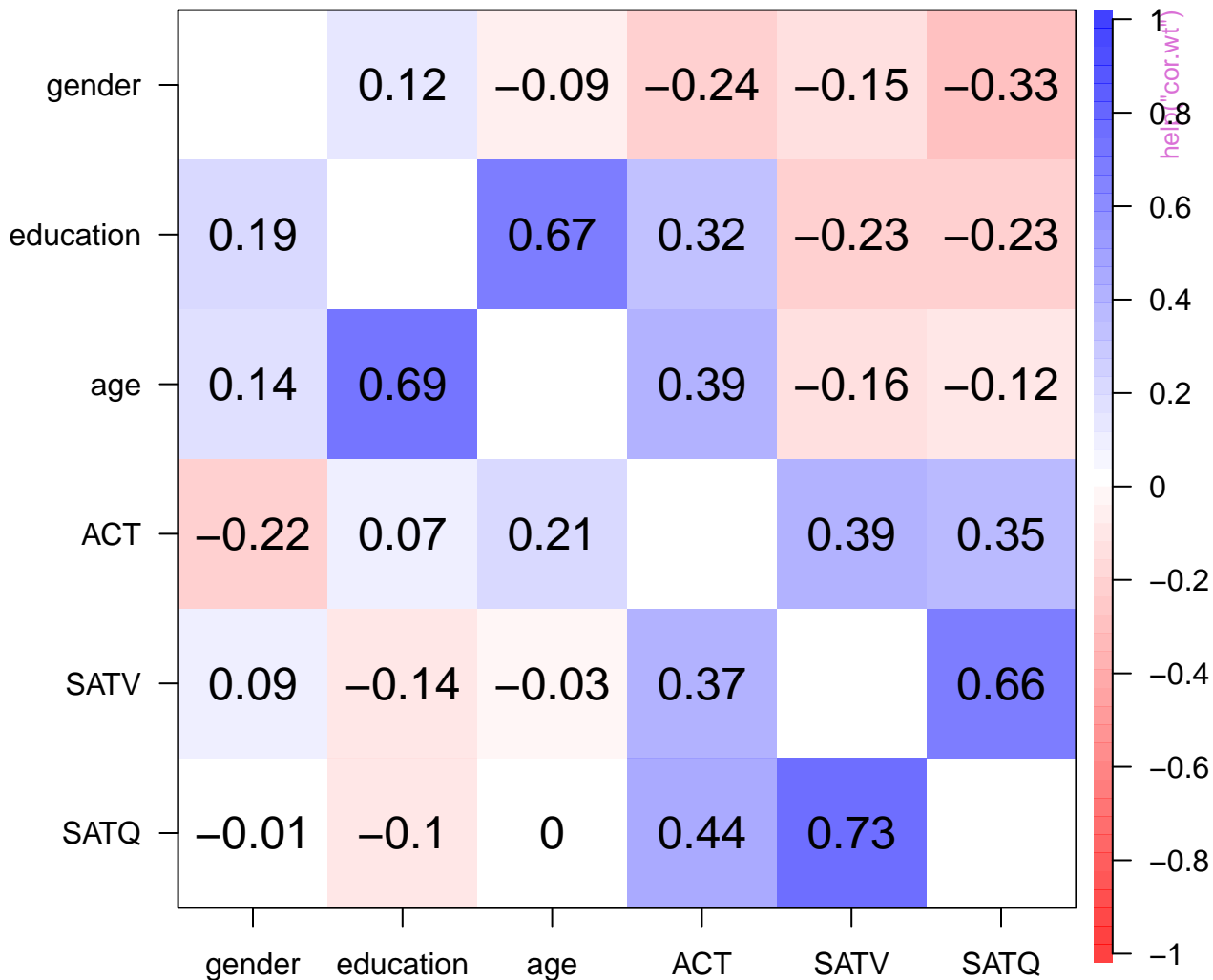

differences of weighted versus unweighted correlations

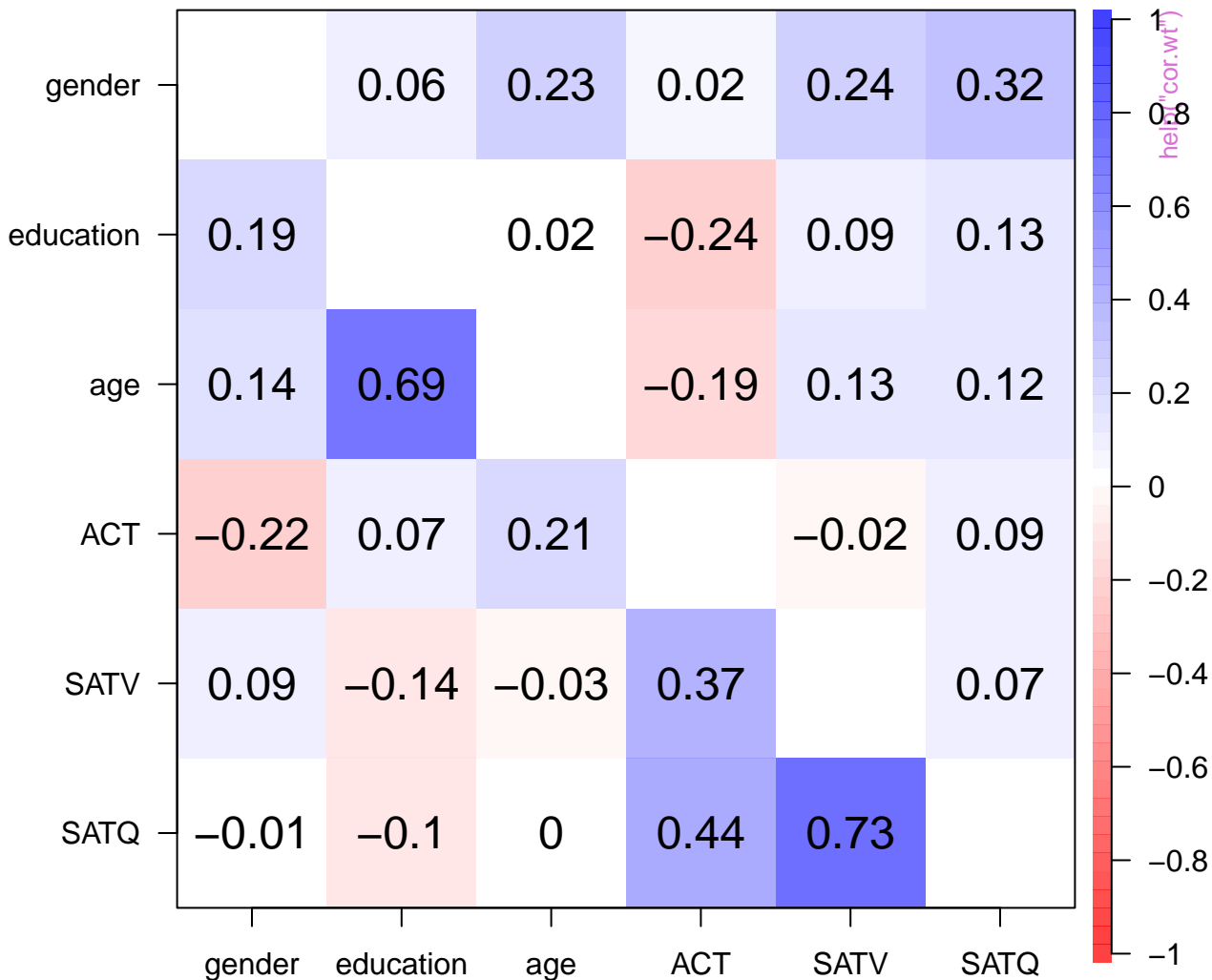

Pure circadian arousal rhythms

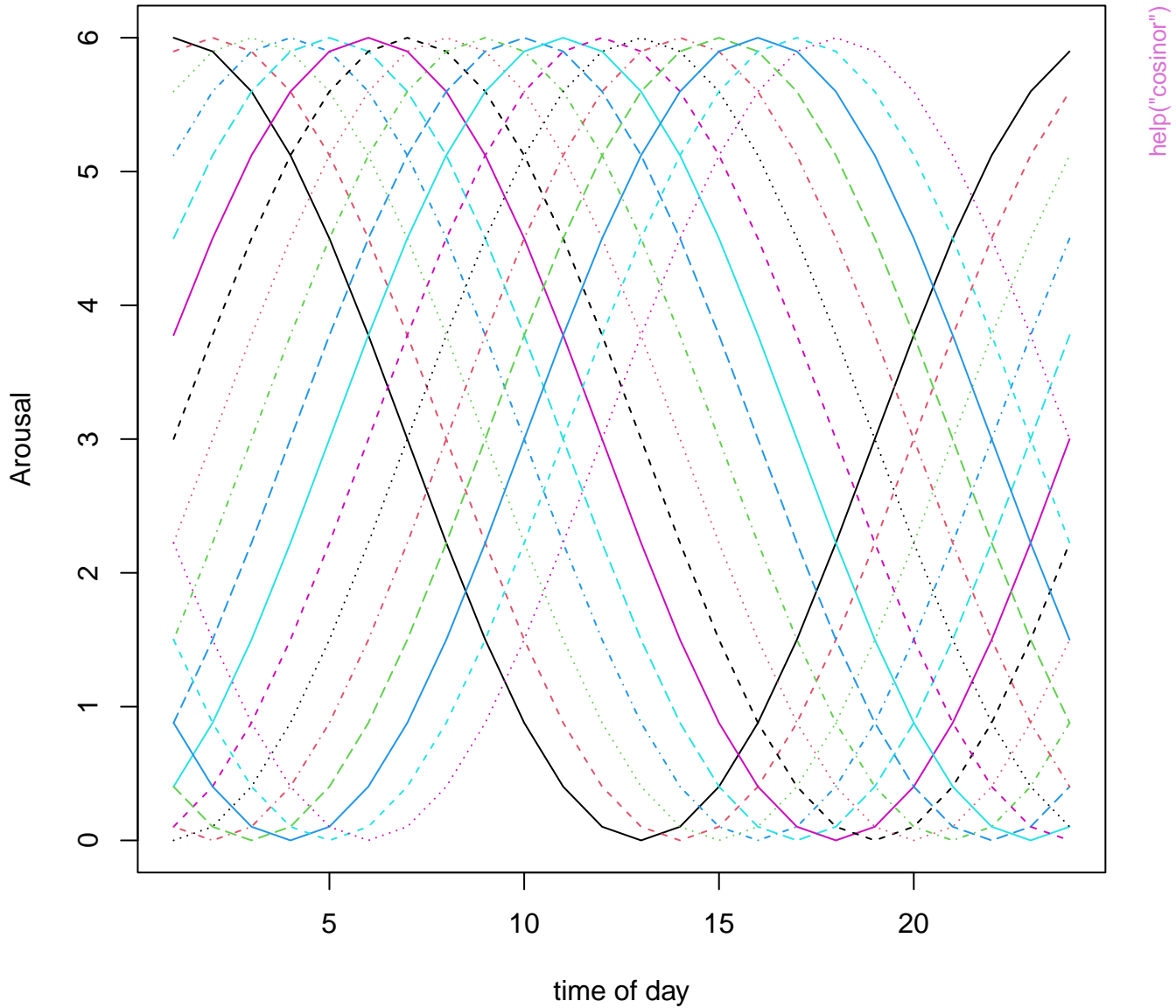

ID = 3 2
2

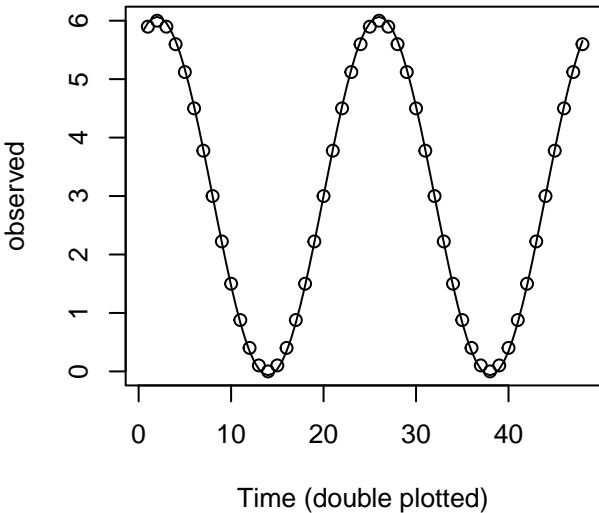

ID = 5 4
4

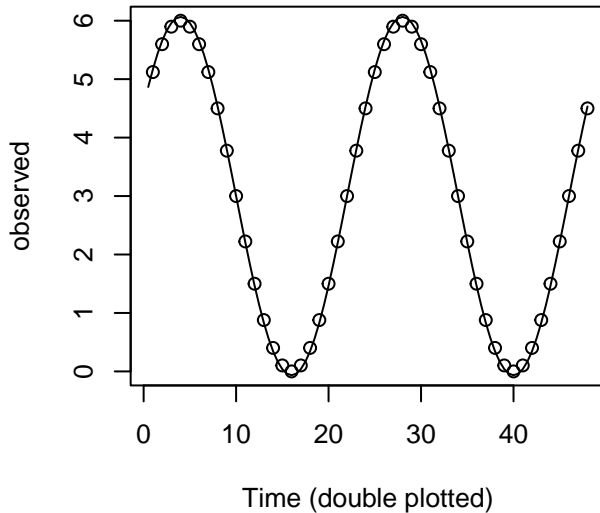

help("cosinor")

ID = 8 7
7

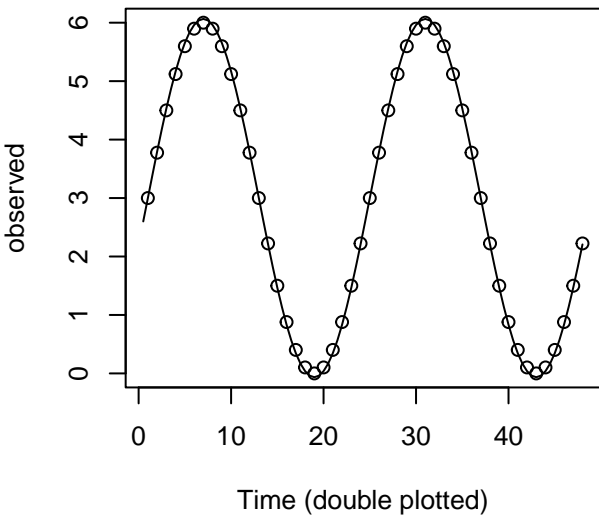

ID = 12 11
11

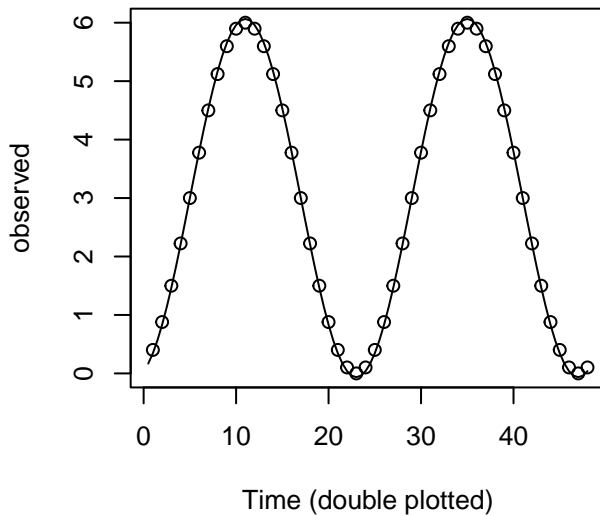

ID = 1 3 1

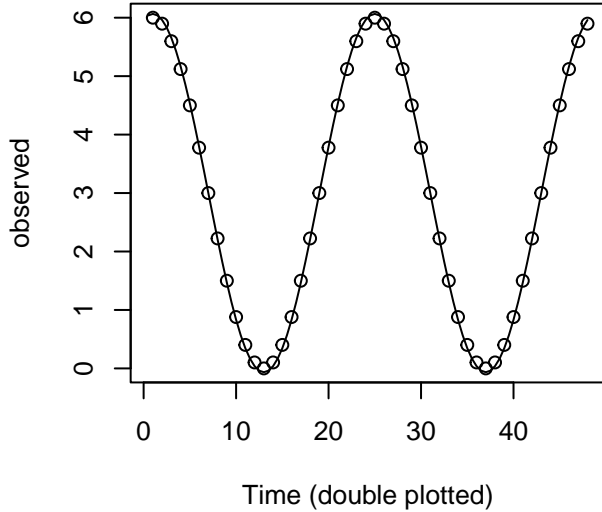

ID = 2 3 4

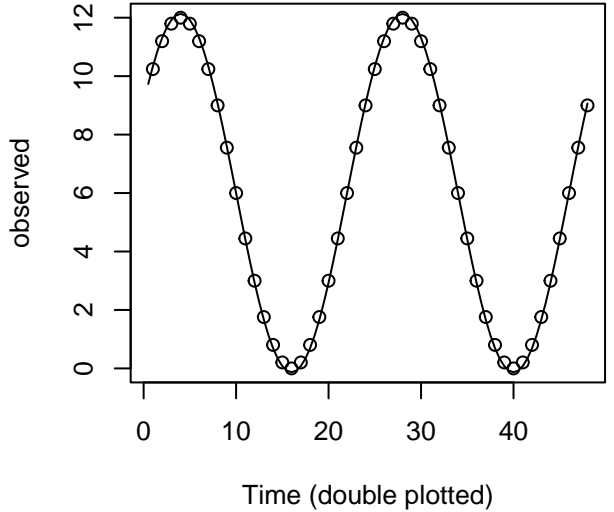

help("cosinor")

ID = 3 3 7

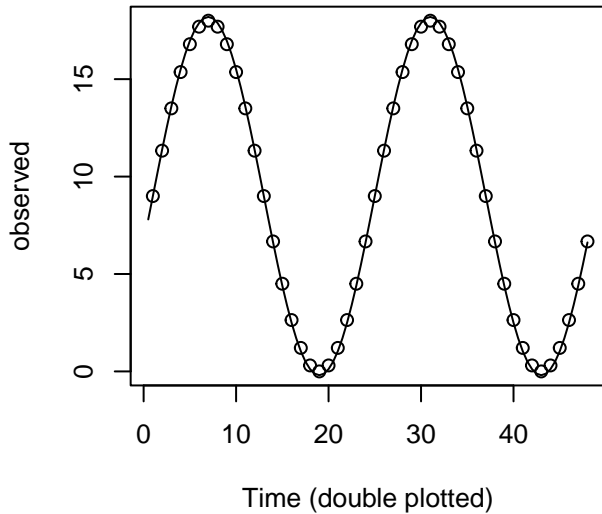

ID = 4 3 10

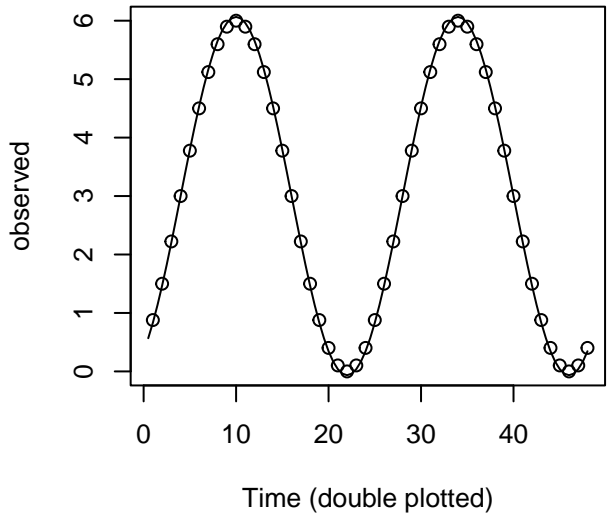

Cosine fit

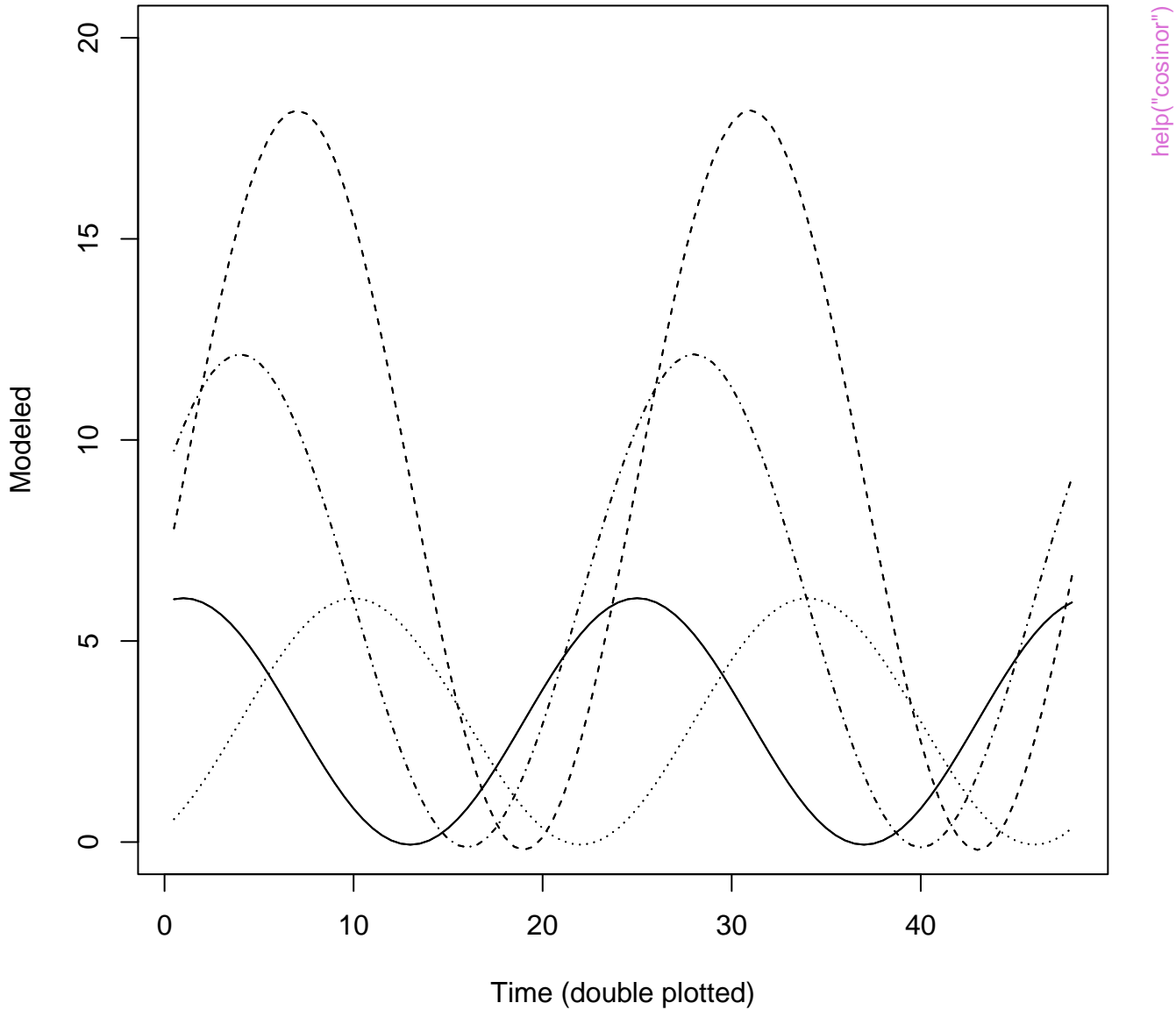

Cosine fit 1.85
1.85

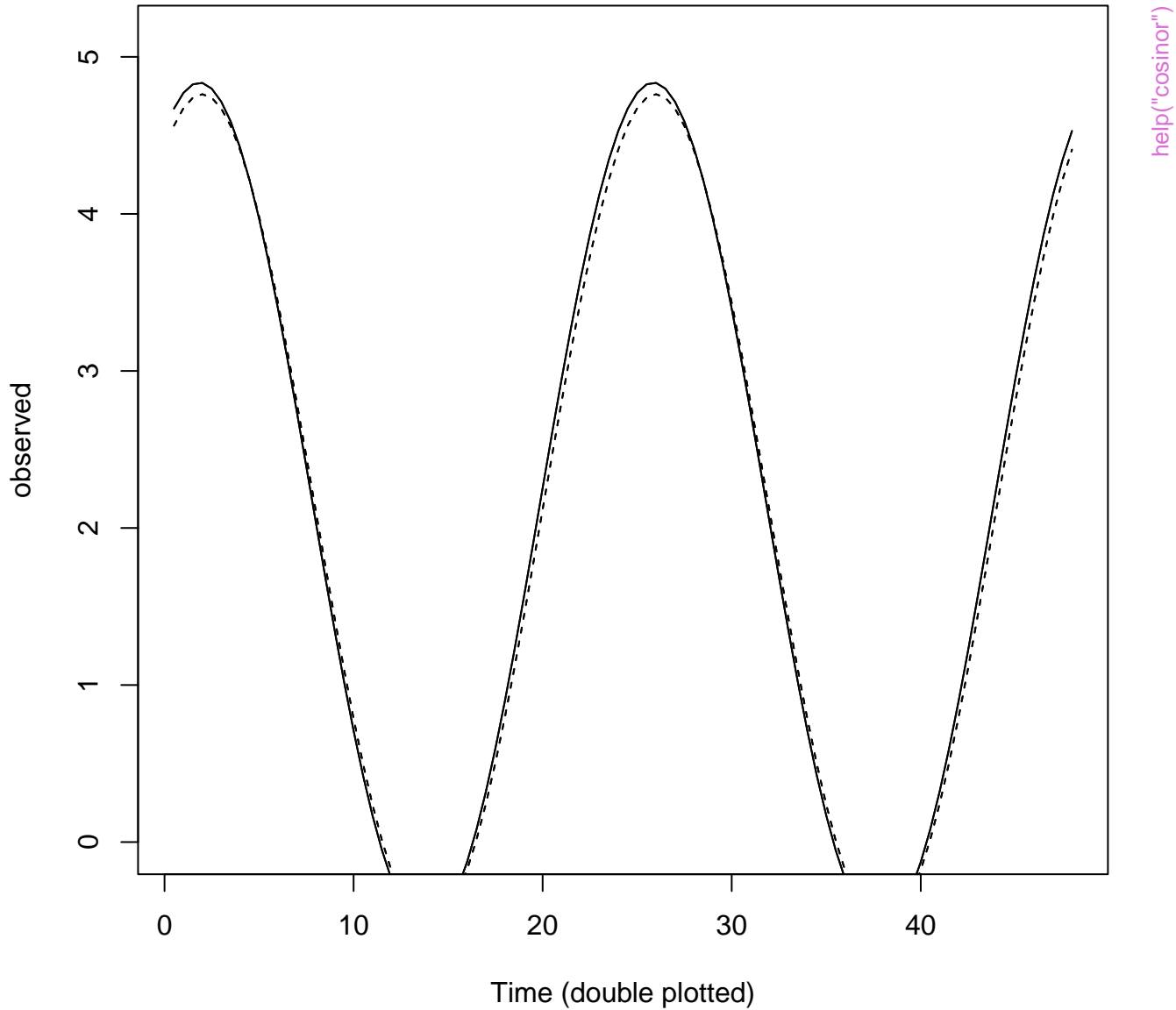

help("cosinor")

Density plot

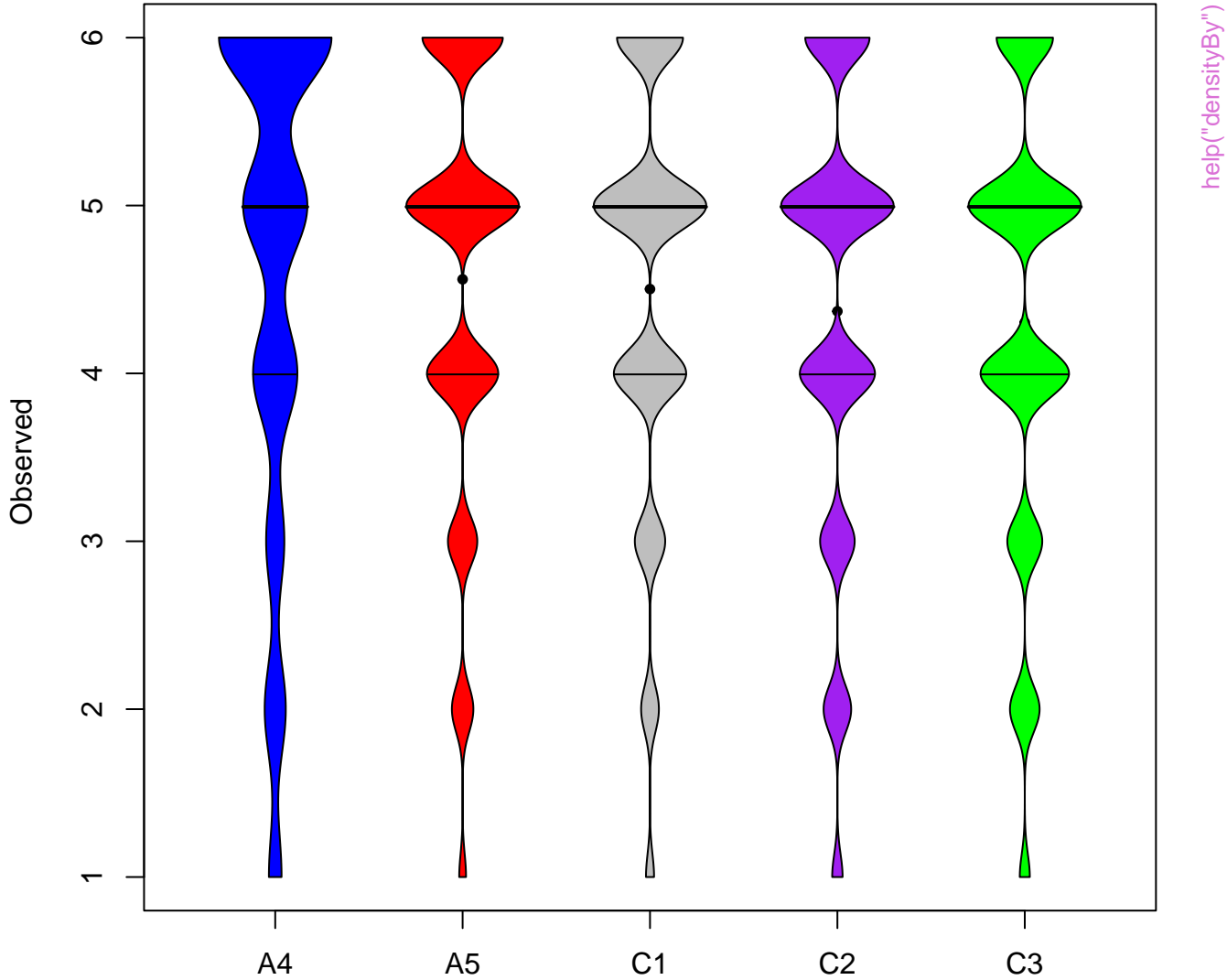

help("densityBy")

Density plot

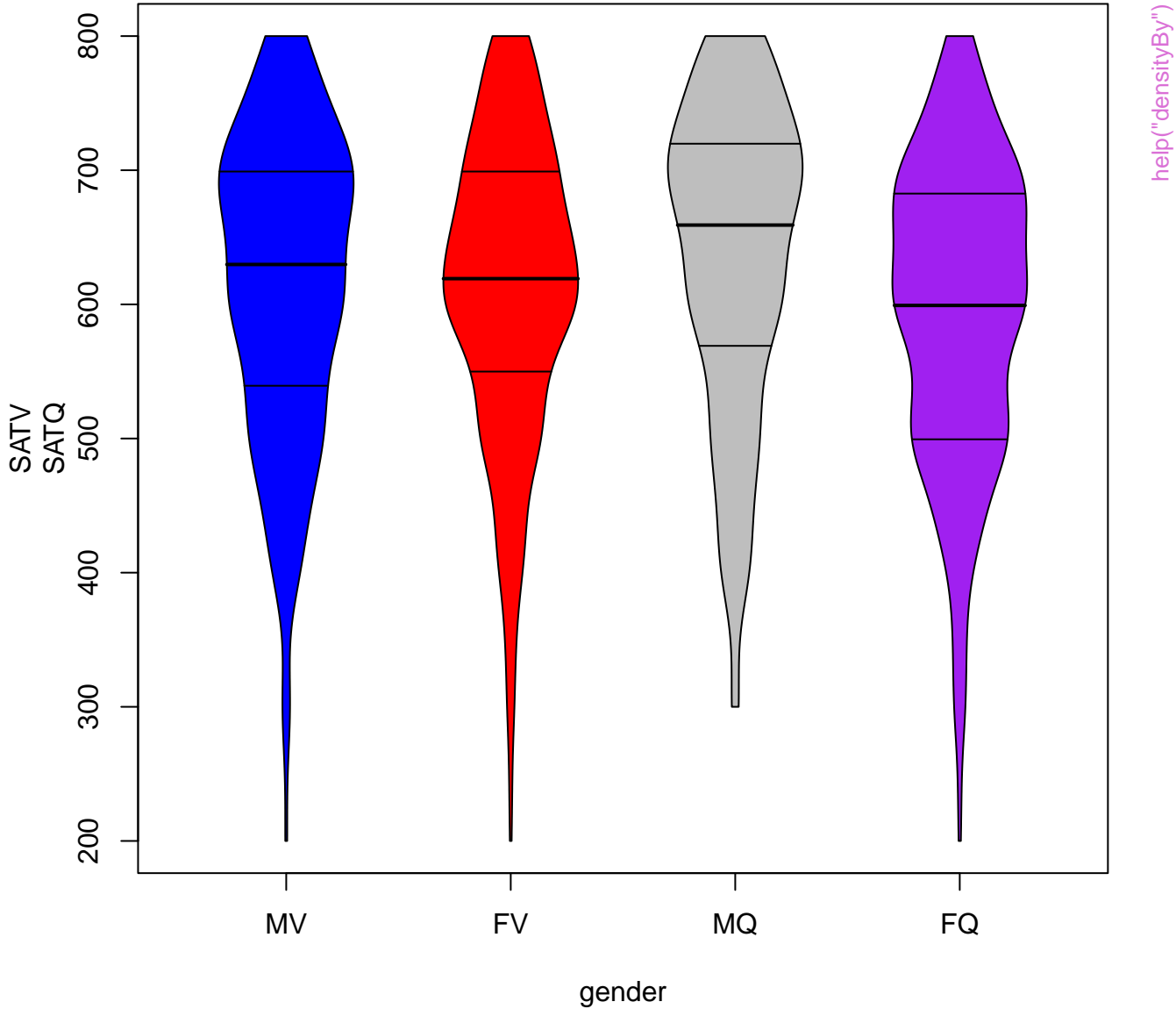

help("densityBy")

Density plot

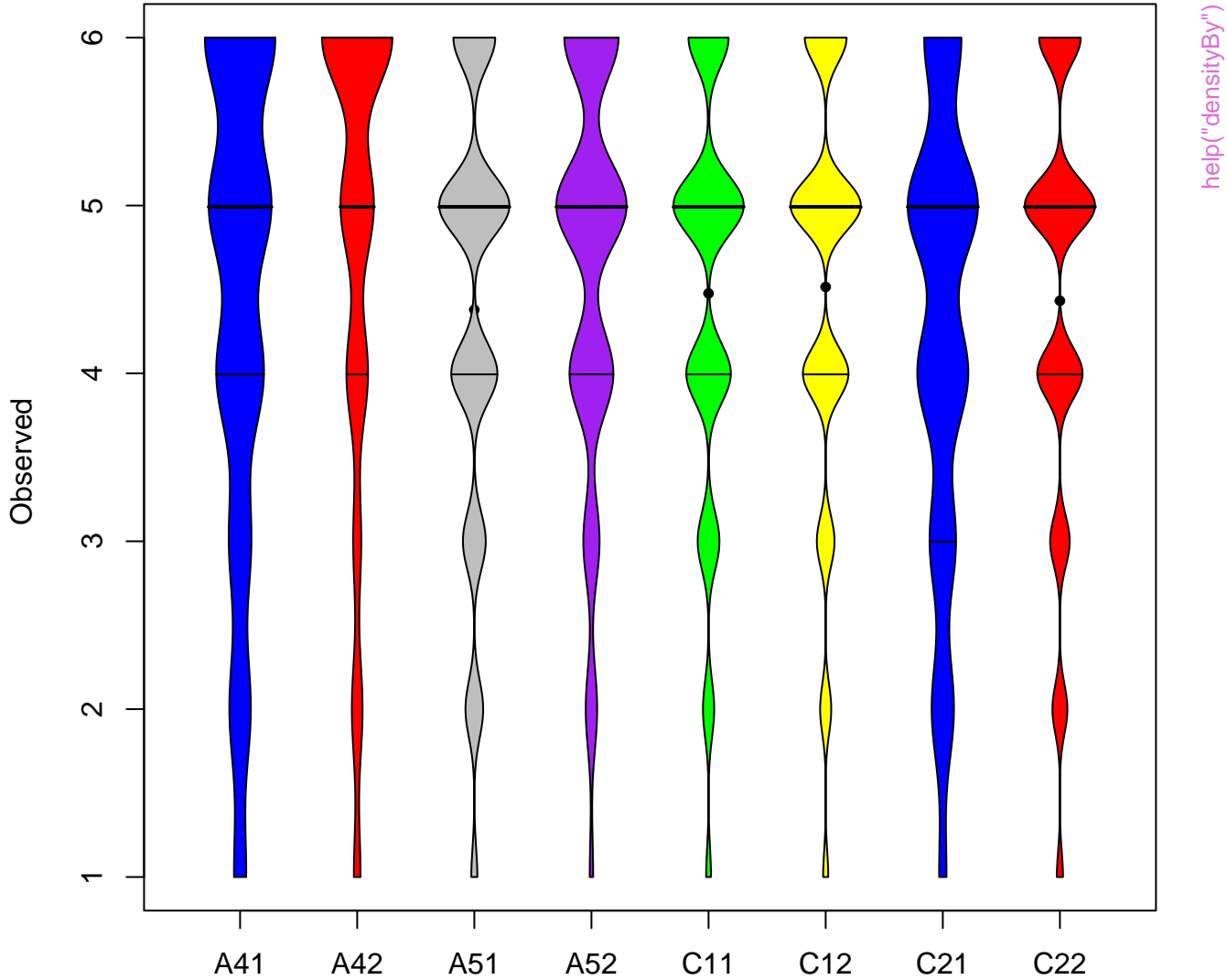

Density Plot

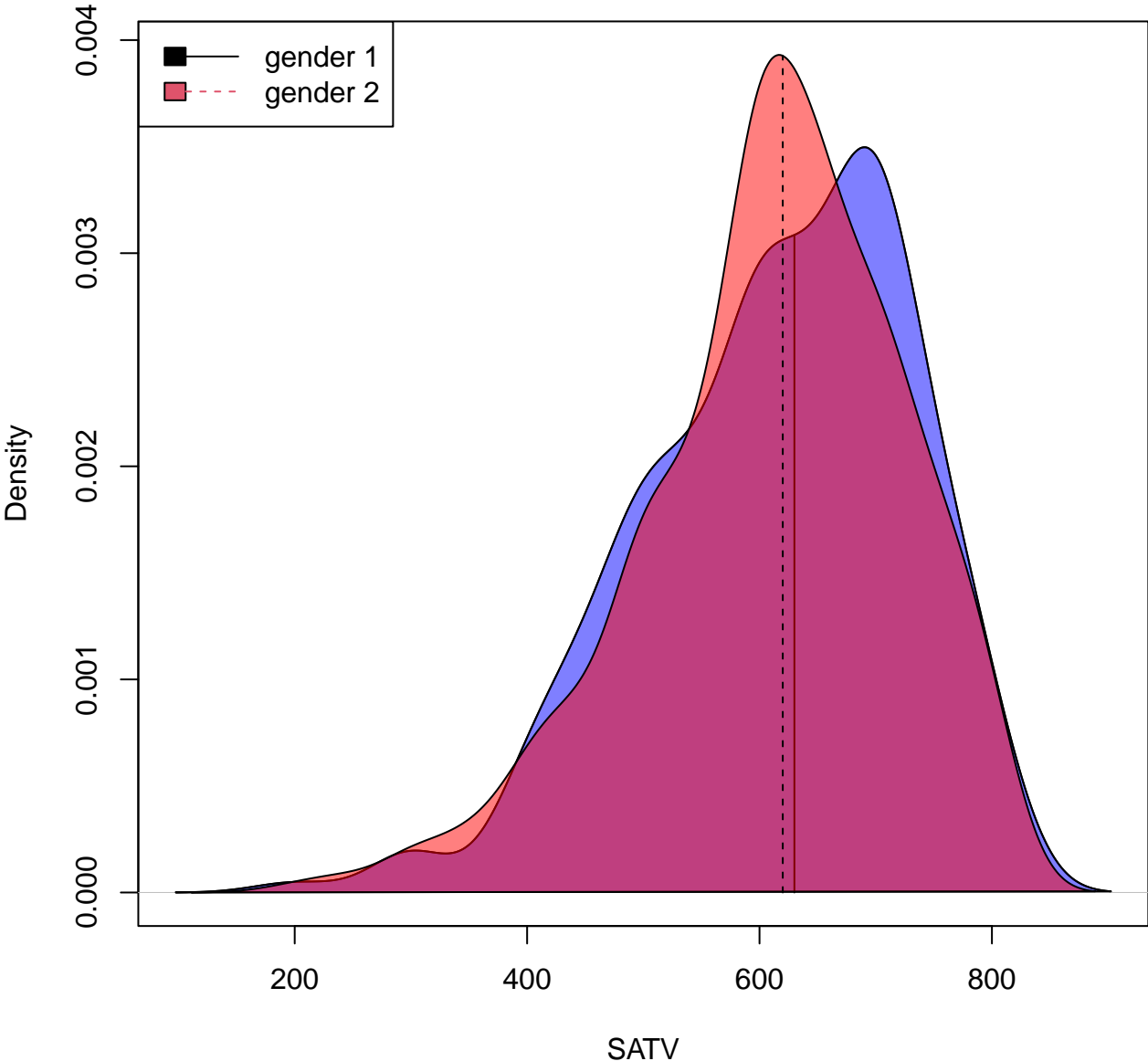

help("densityBy")

Demonstration of diagram functions

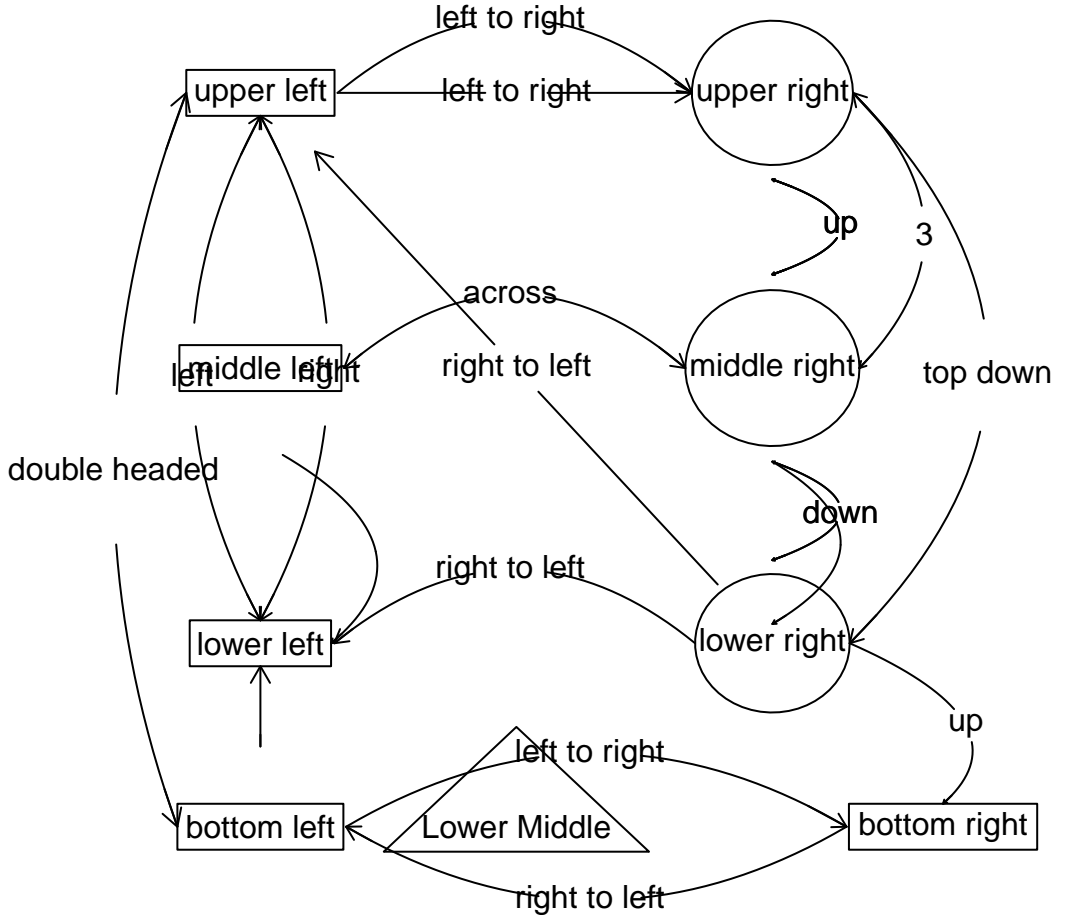

Factor Analysis

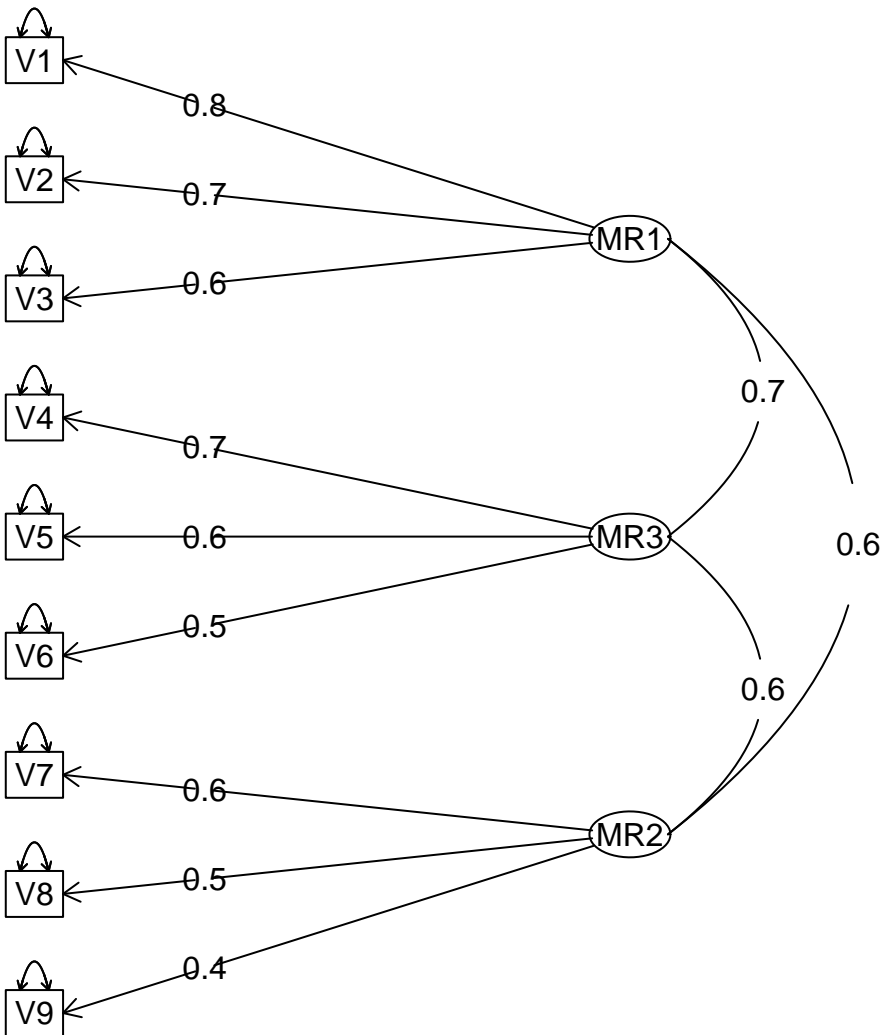

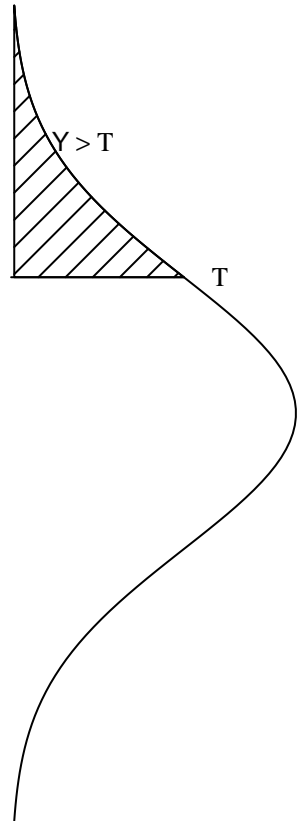
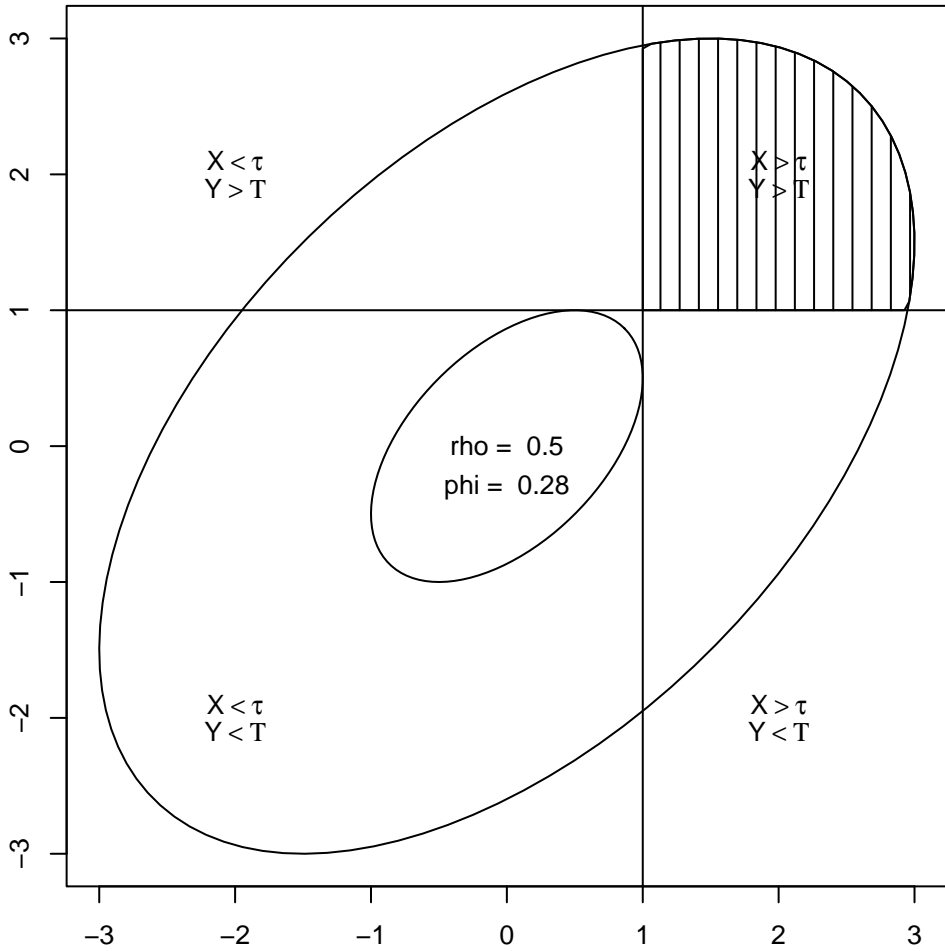
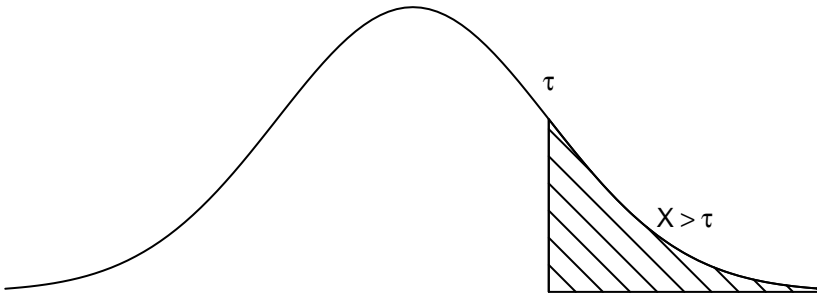

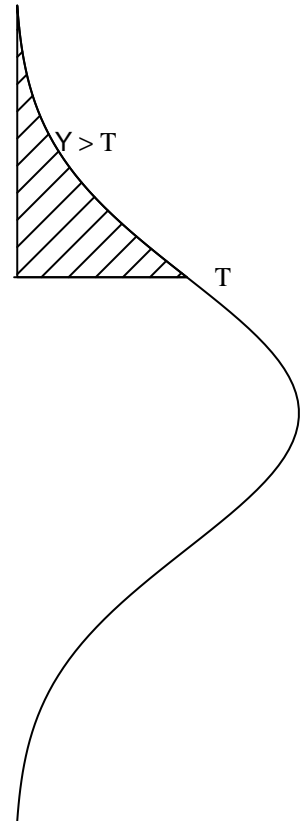
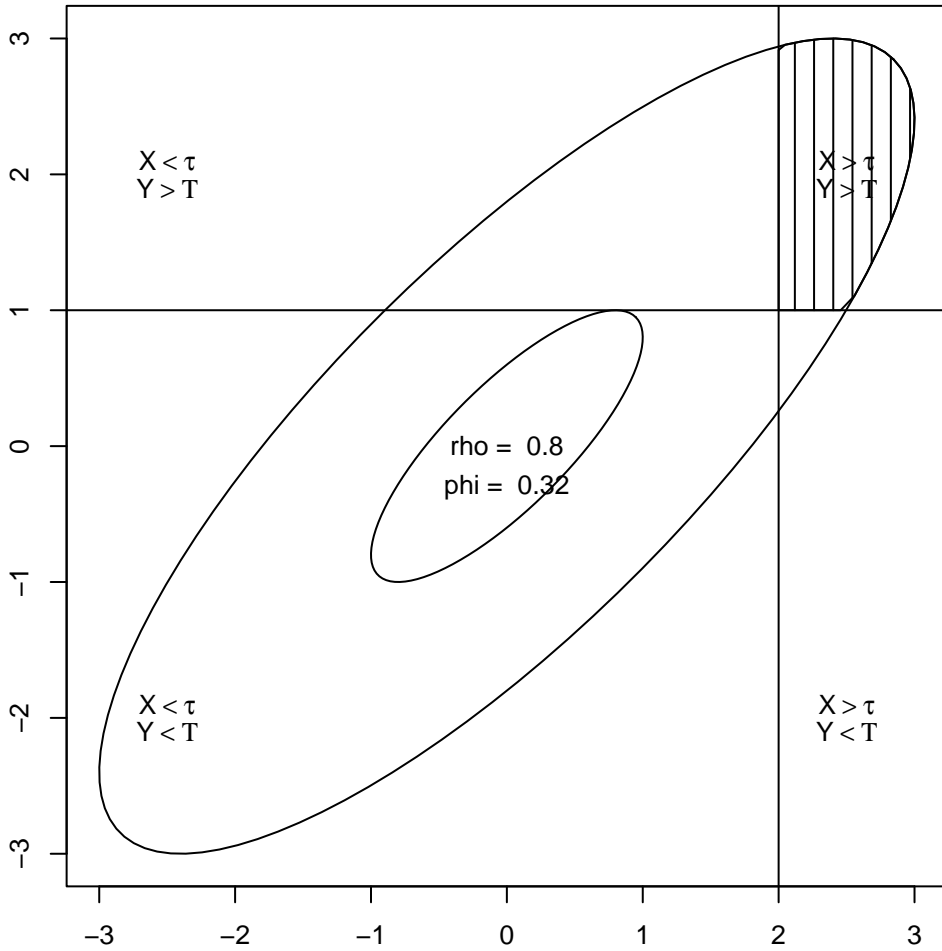
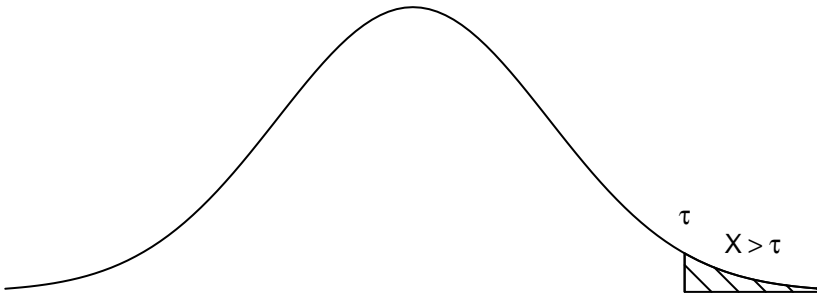

Bivariate density $\rho = 0.5$

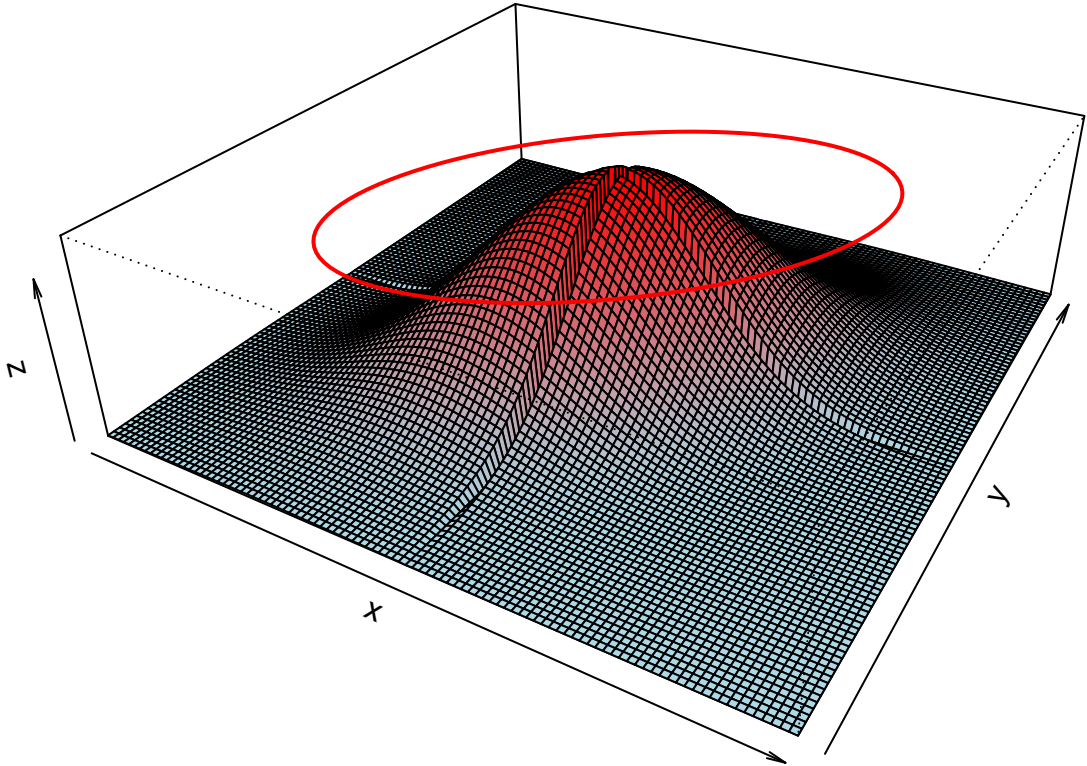

Bivariate density $\rho = 0.5$

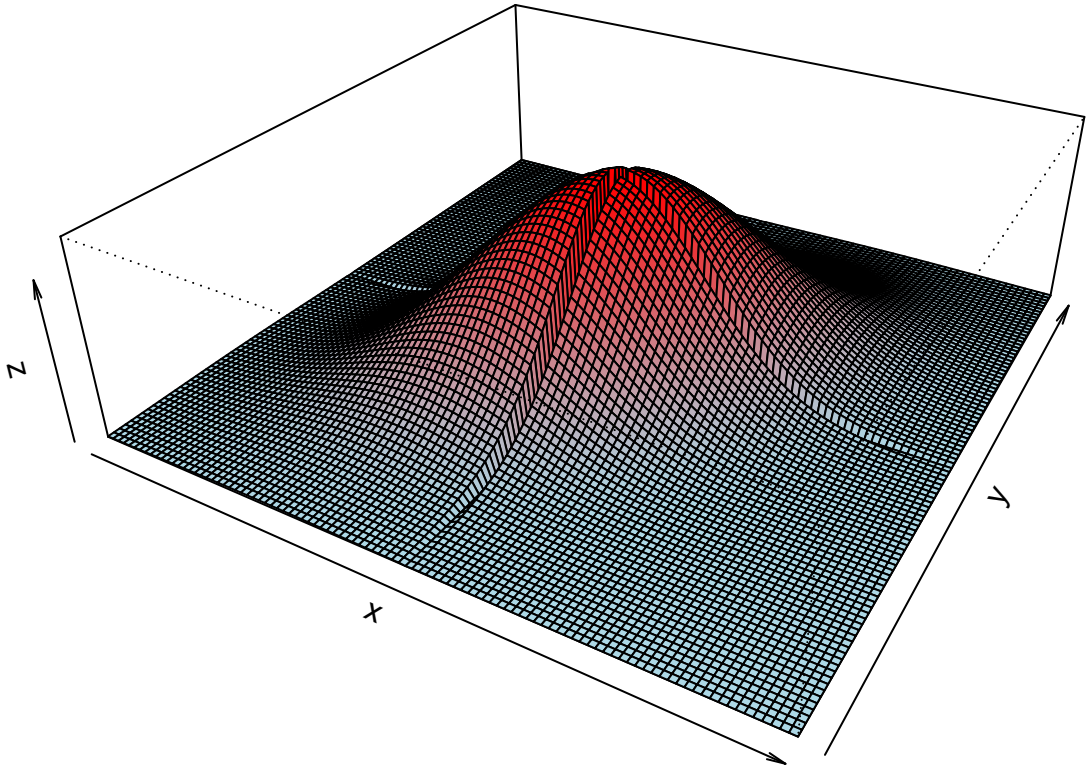

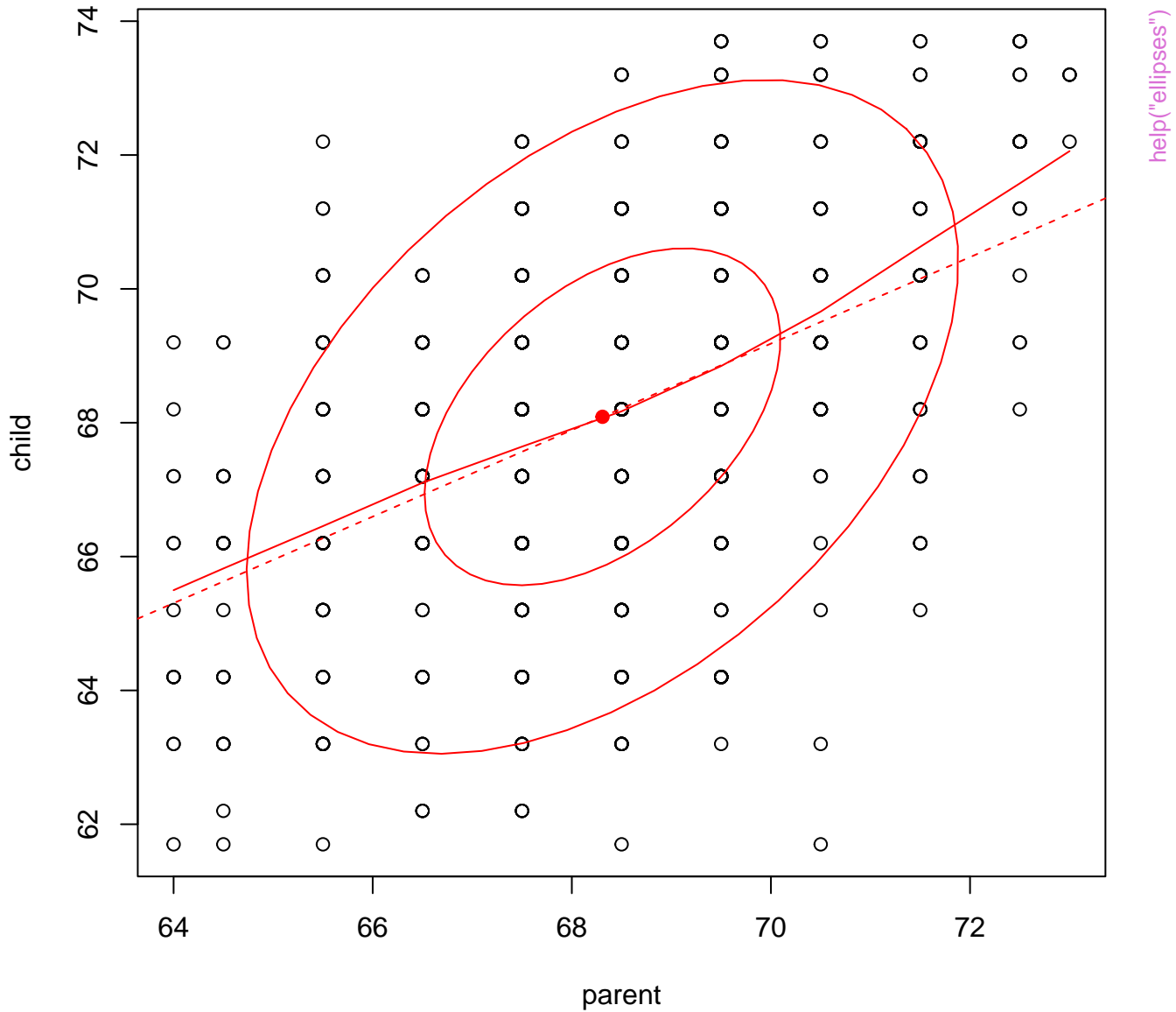

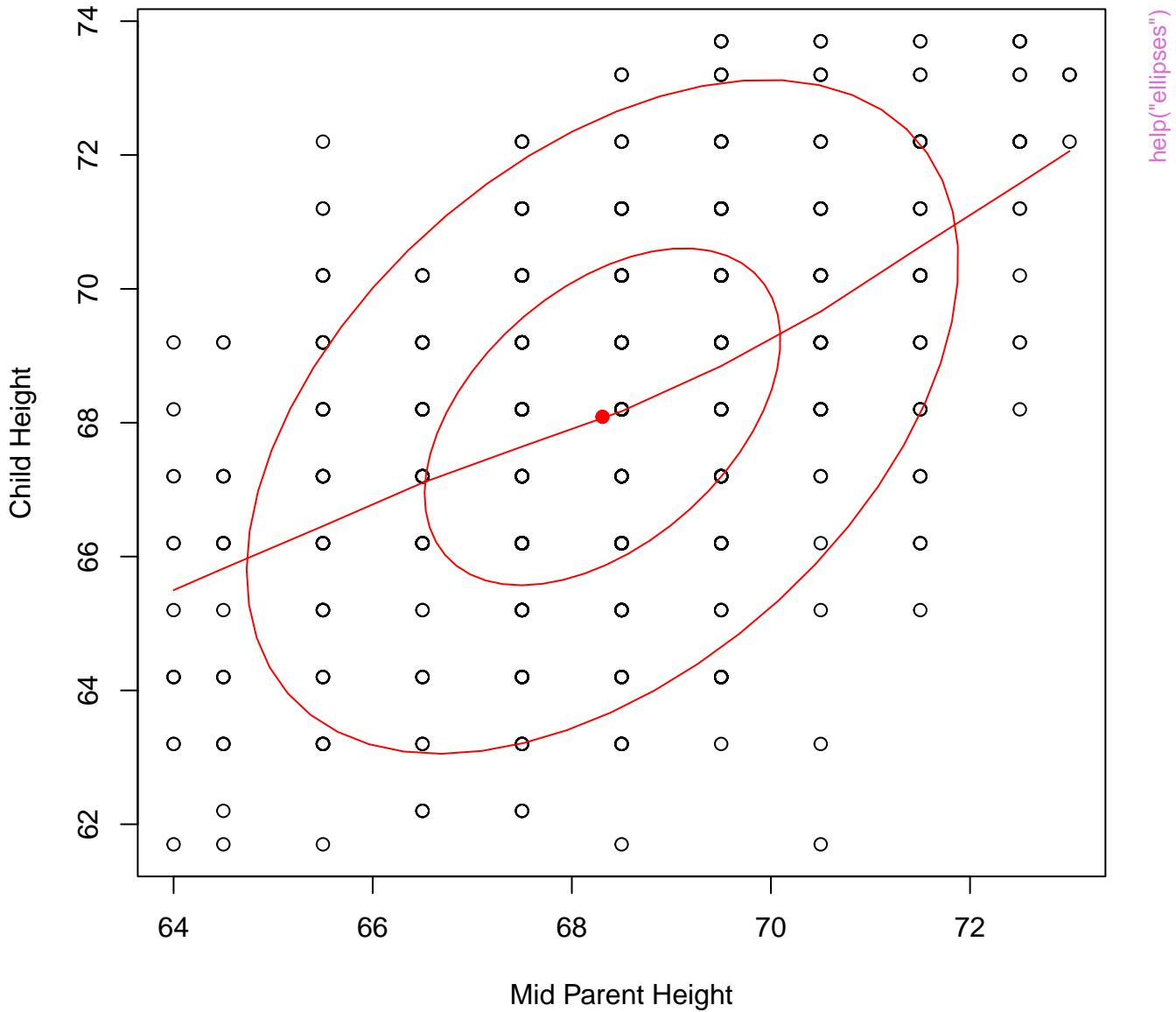

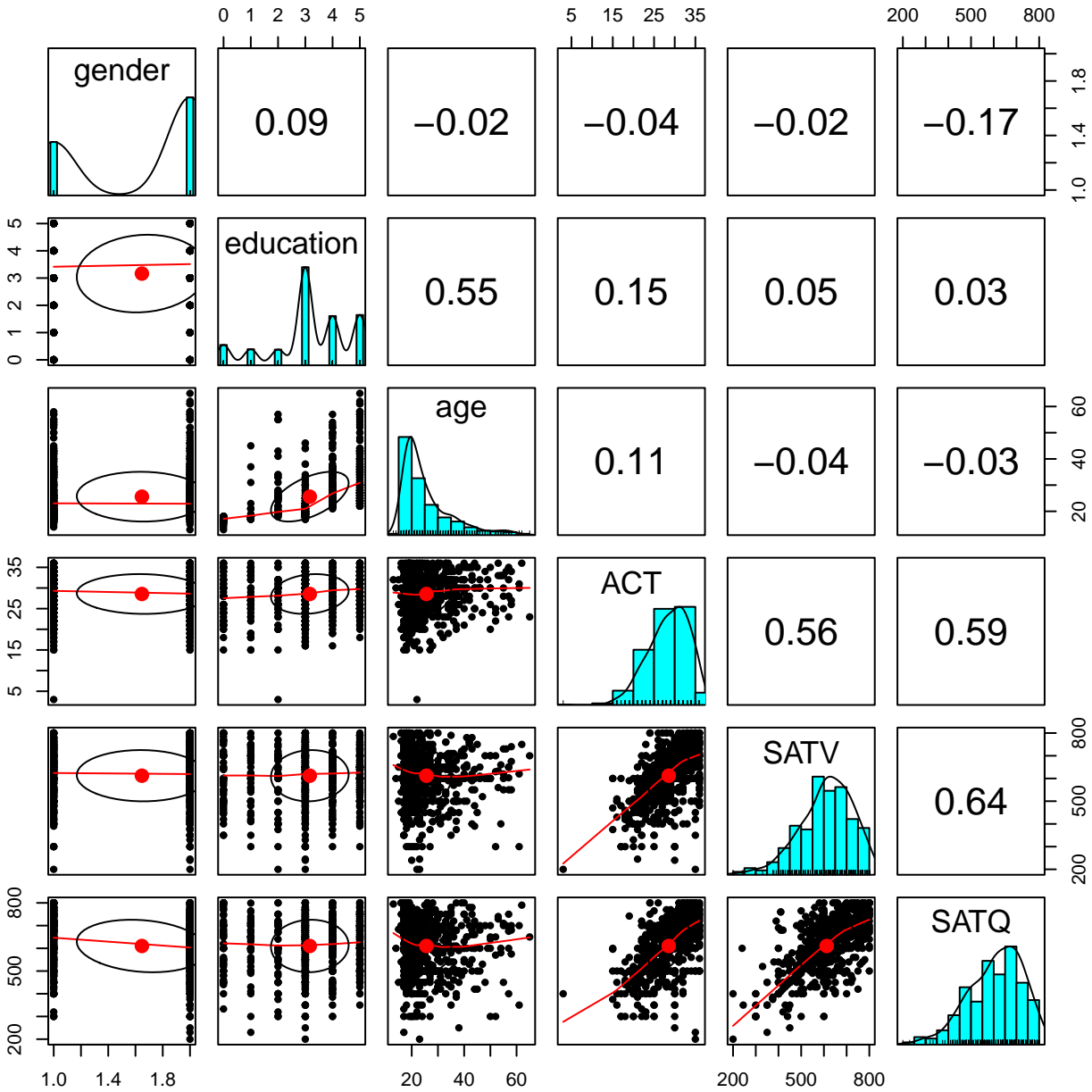

help("ellipses")

Minkowski circles

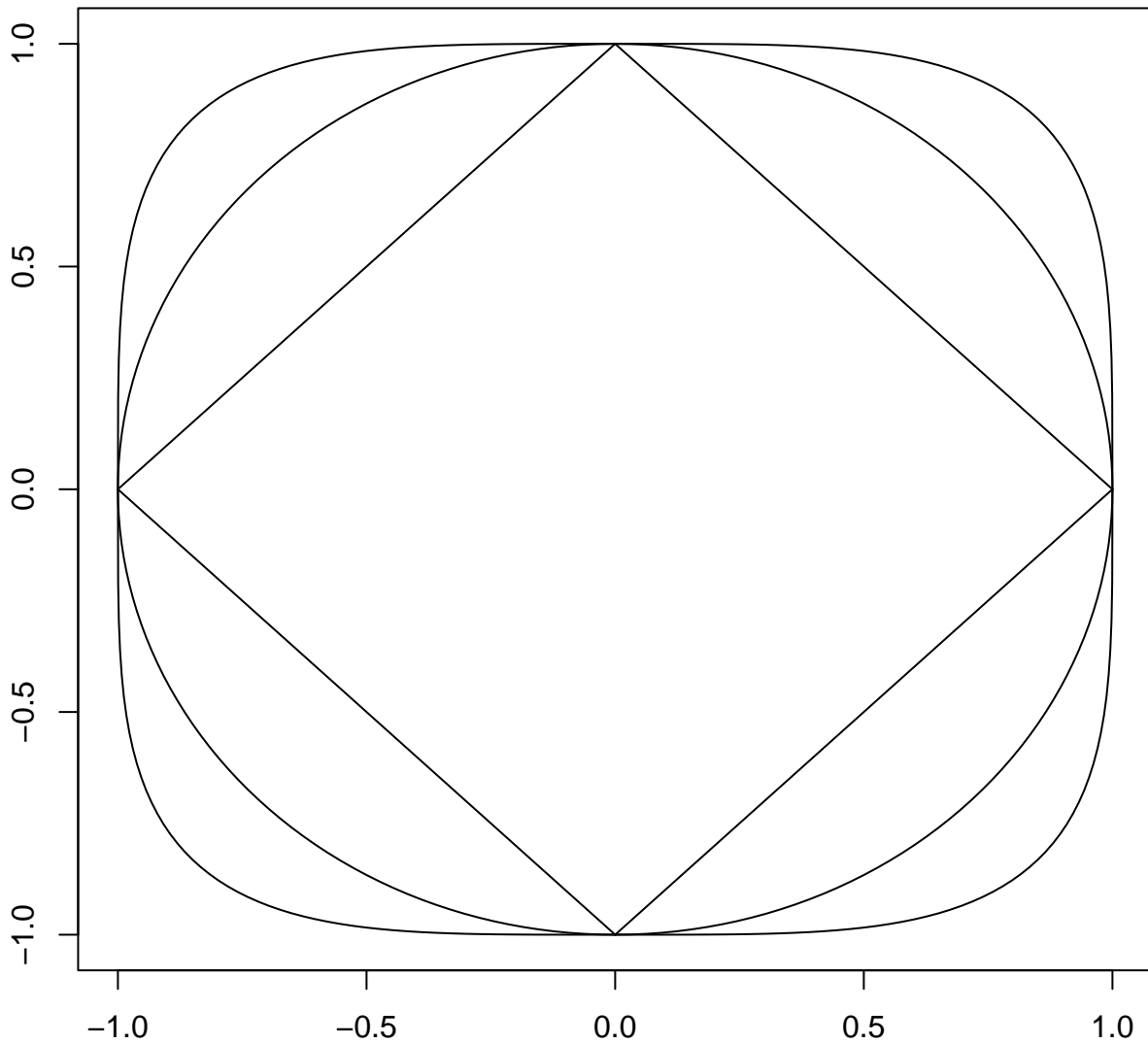

Notched boxplot with error bars

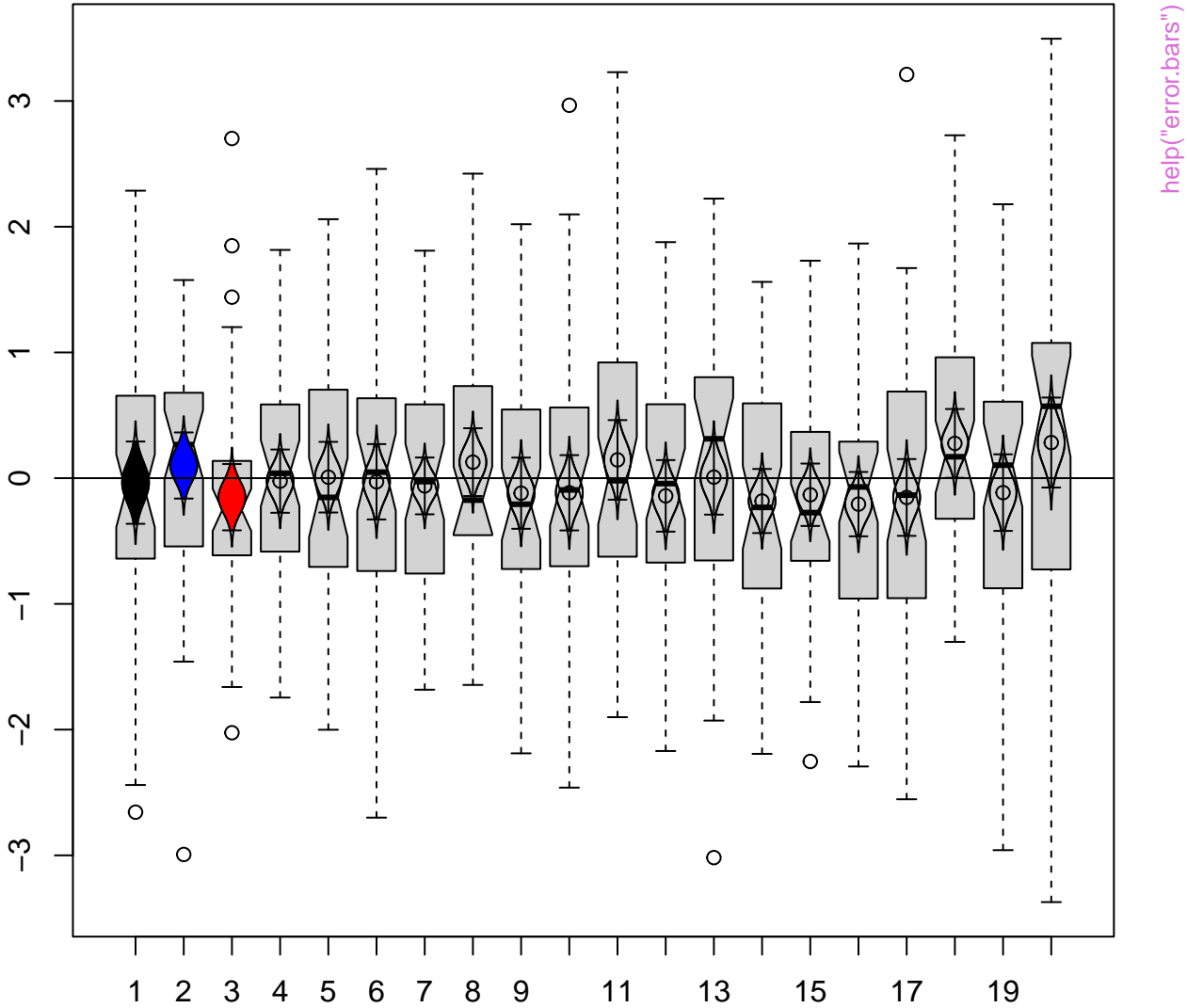

50 percent confidence limits

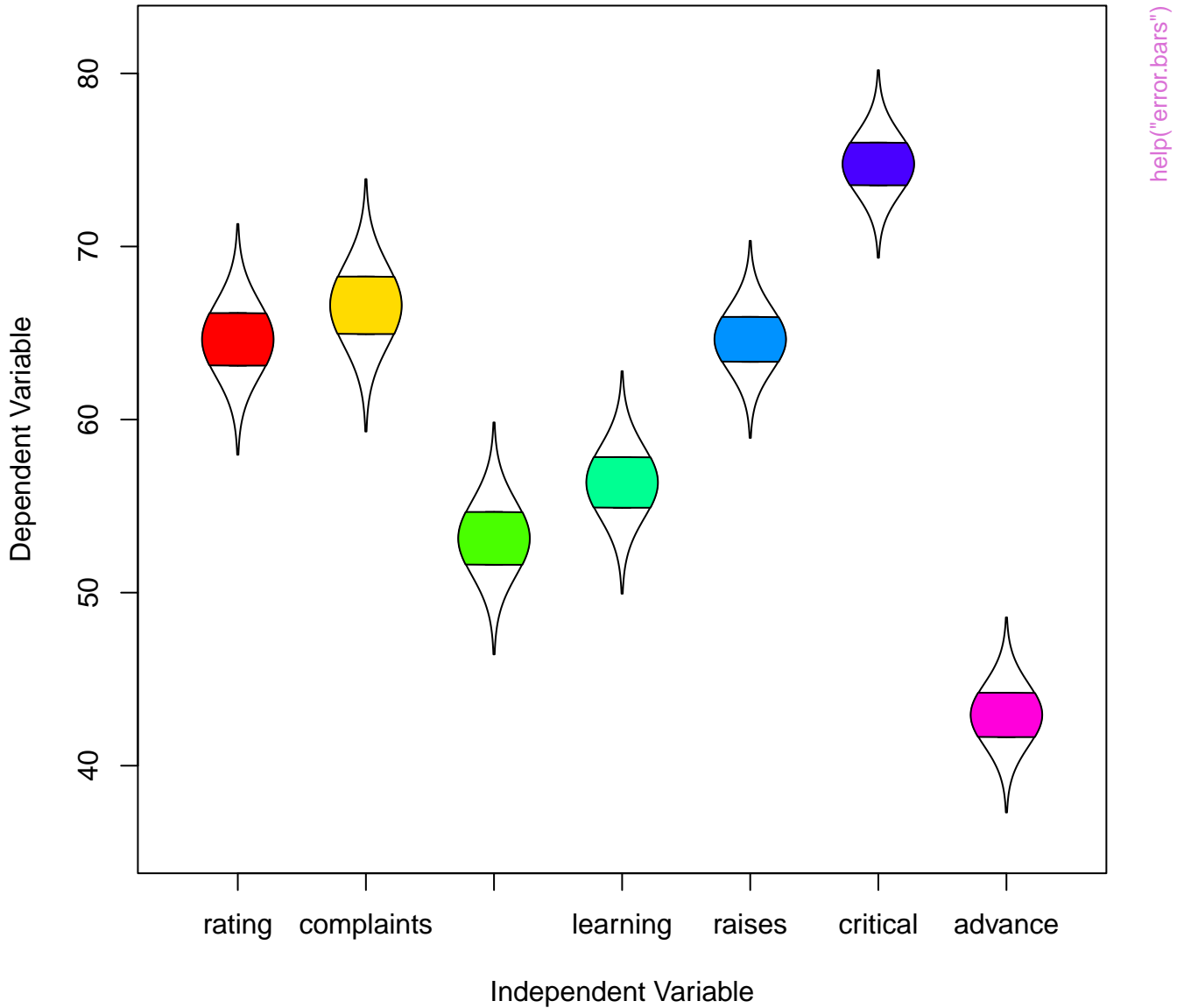

help("error bars")

95% confidence limits

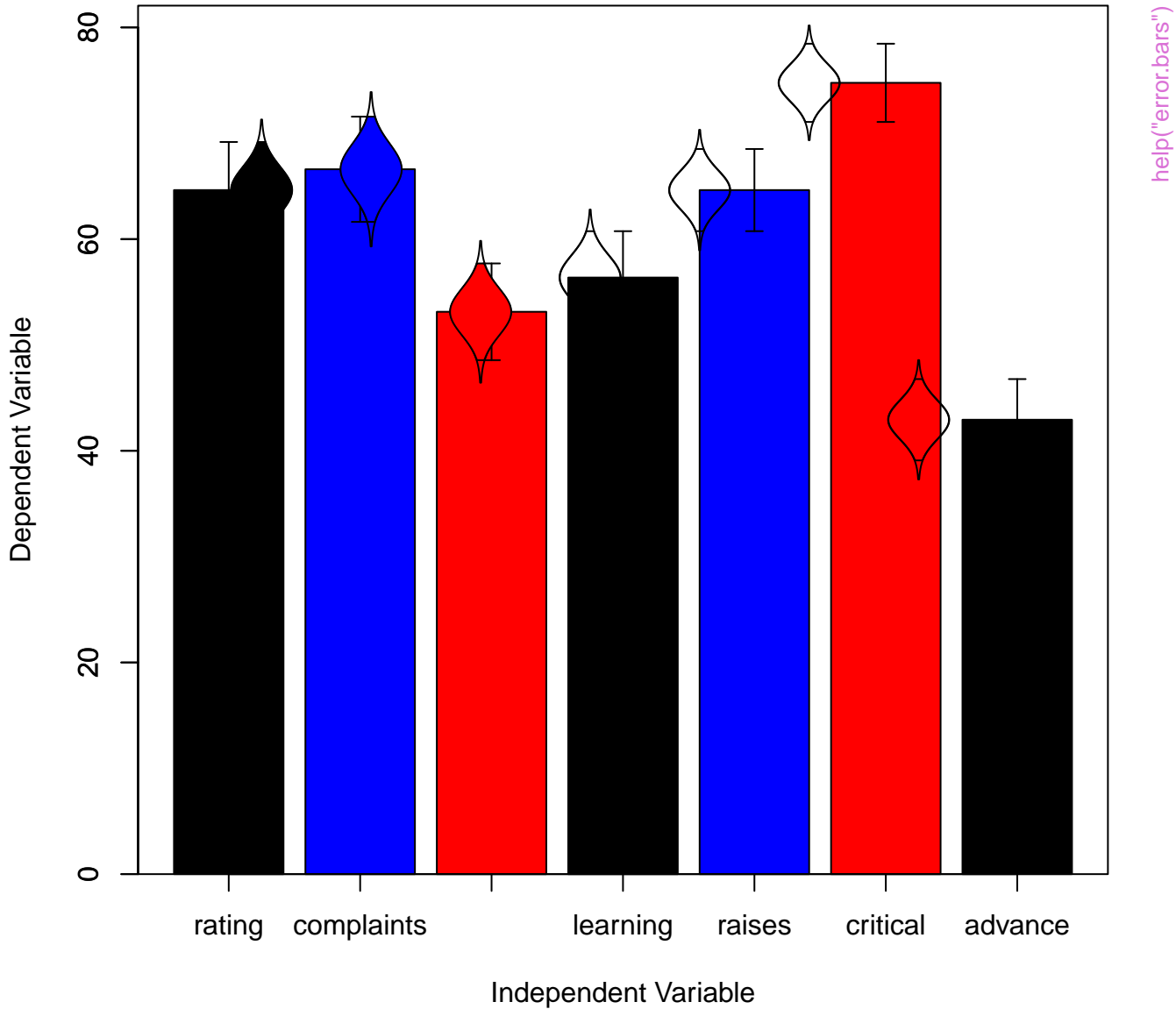

Stripchart with 95 percent confidence limits

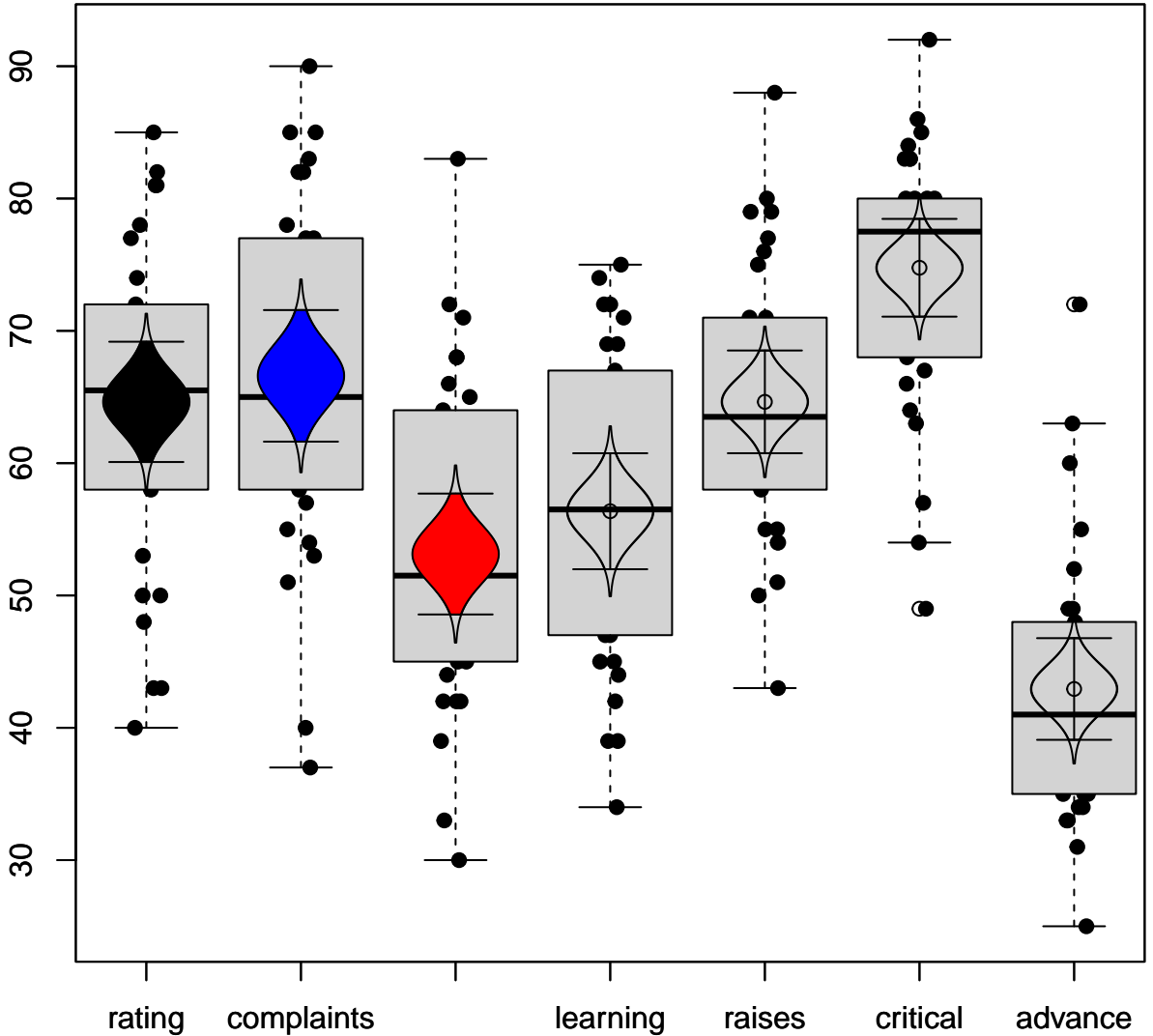

help("error bars")

data with confidence intervals

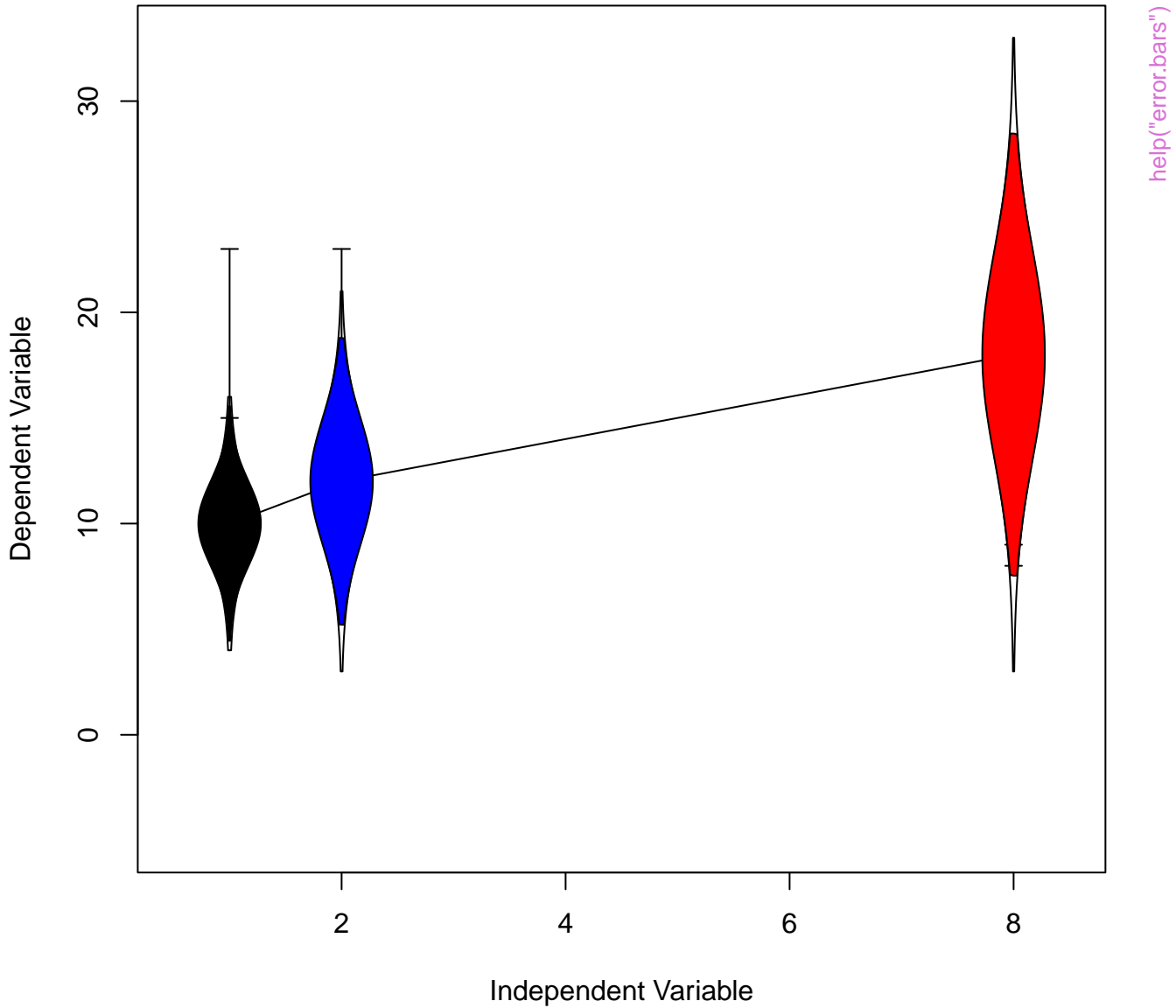

data with confidence intervals

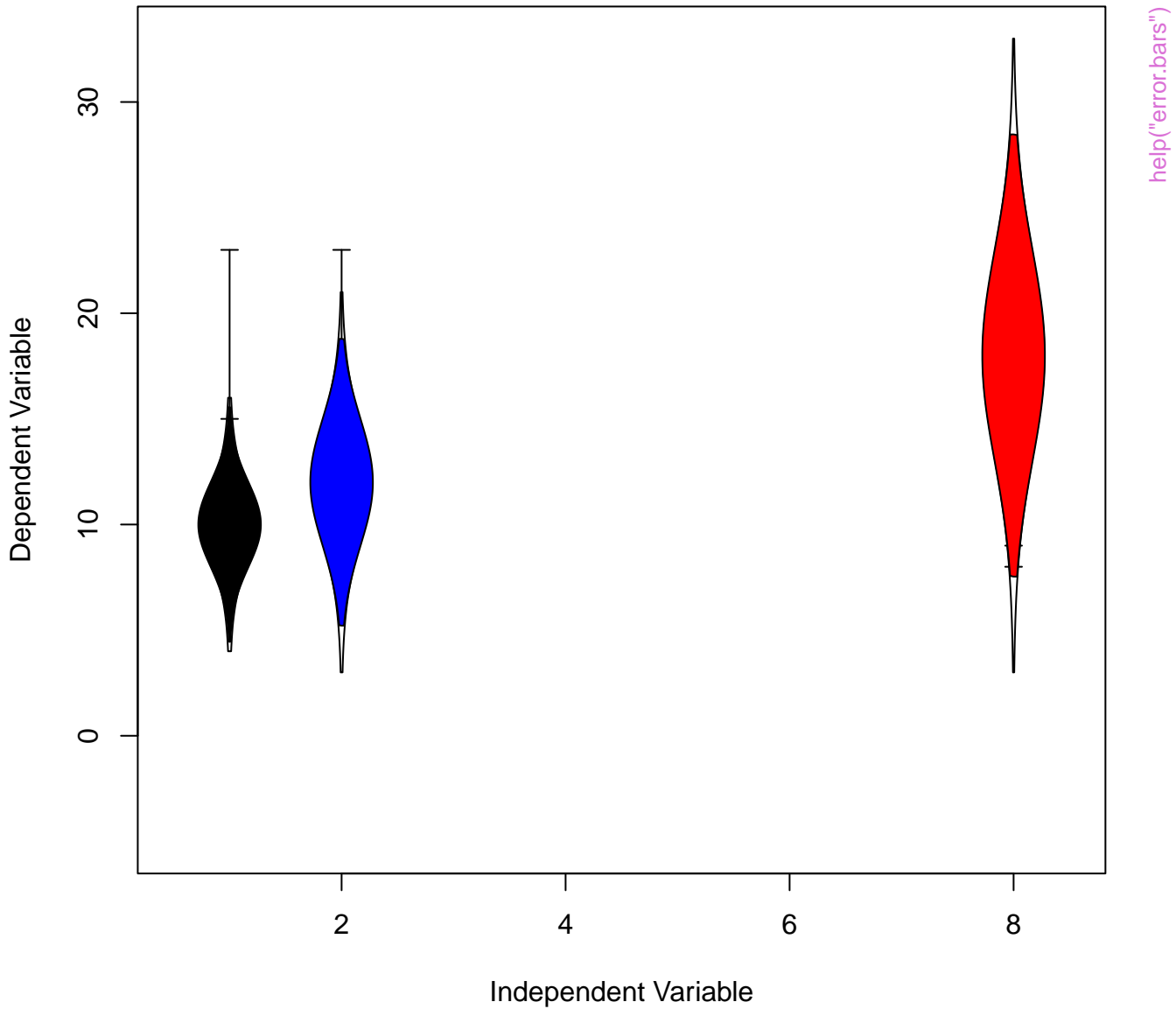

help("error bars")

95% confidence limits

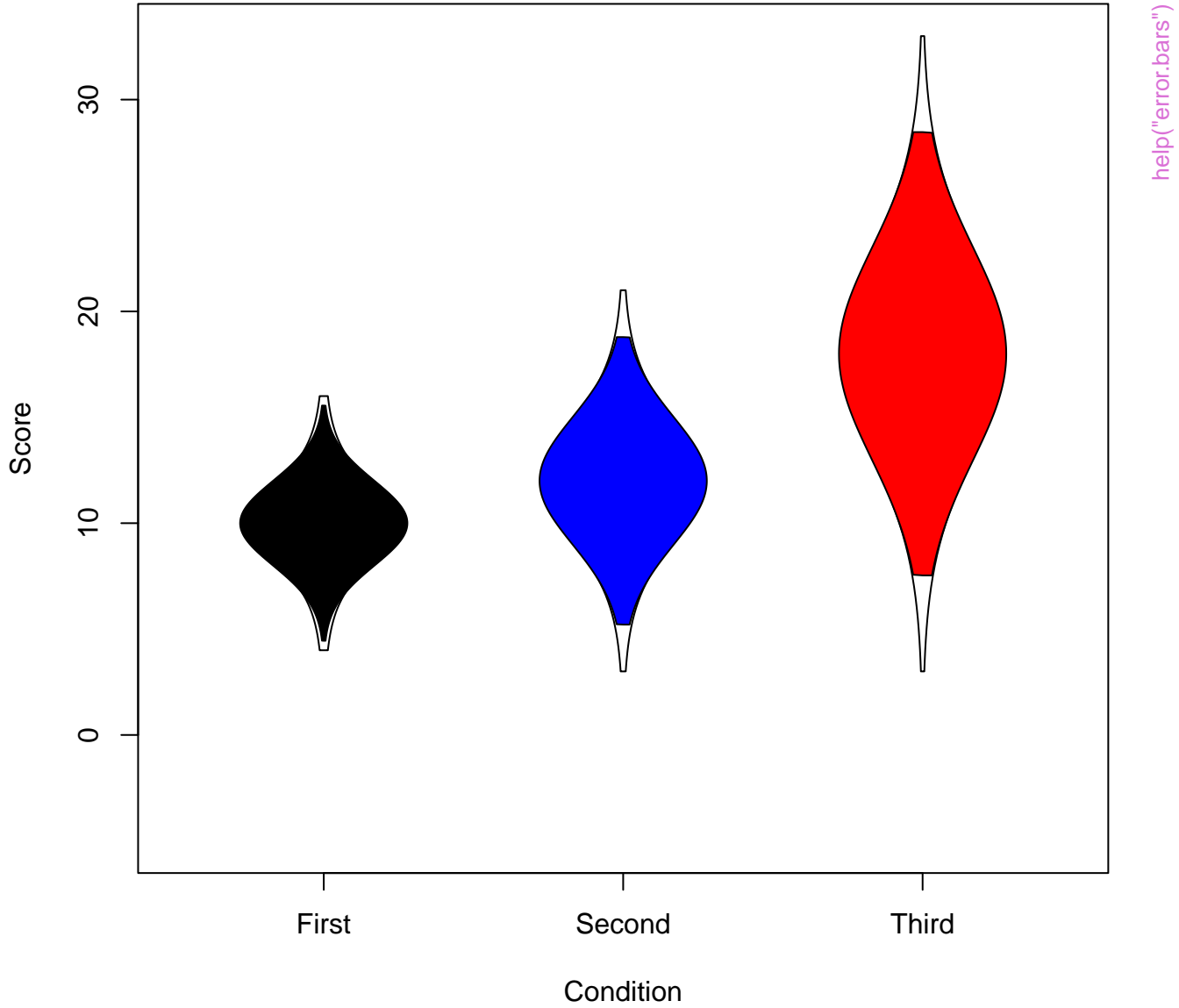

95% confidence limits

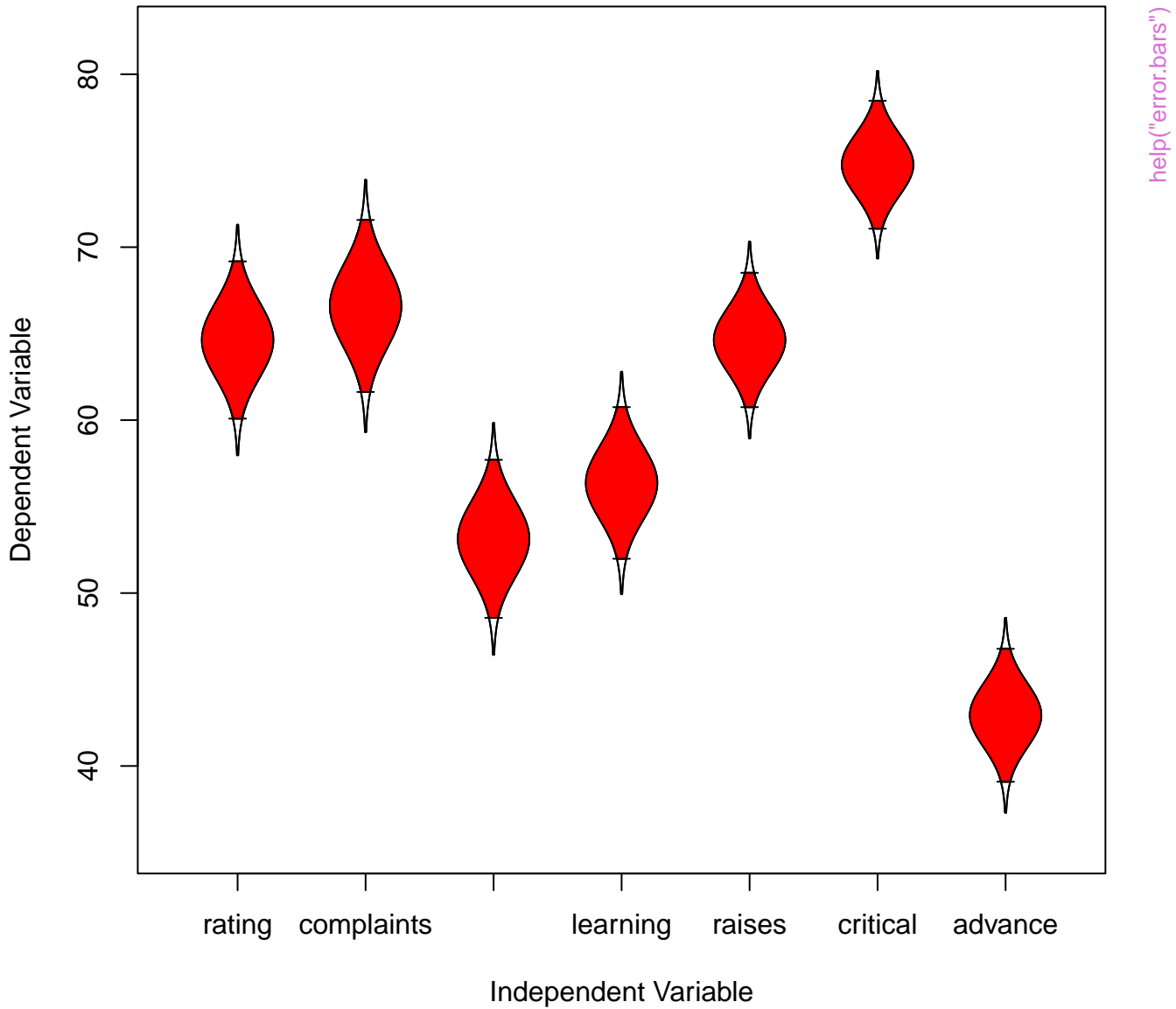

95% confidence limits

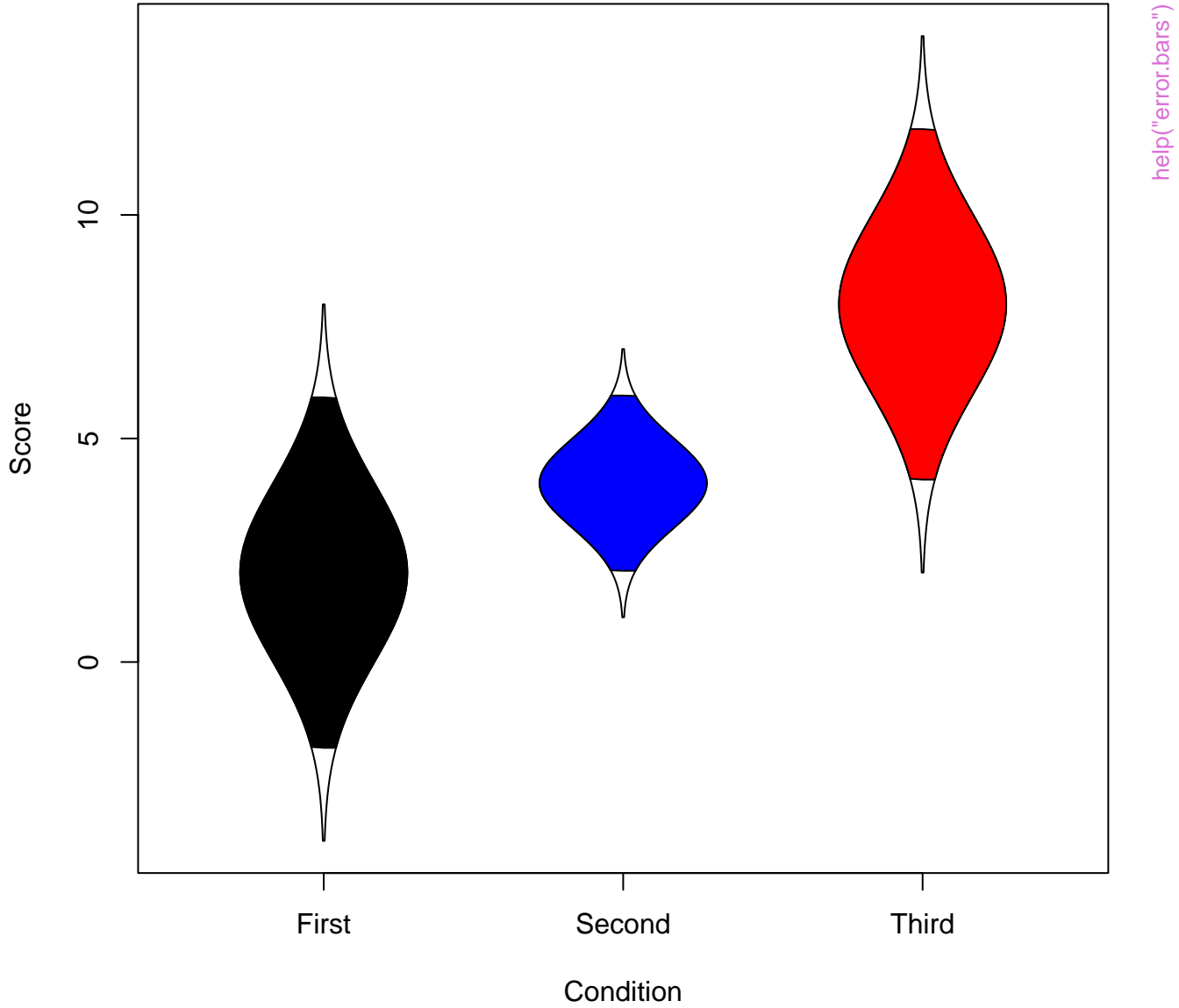

95% confidence limits

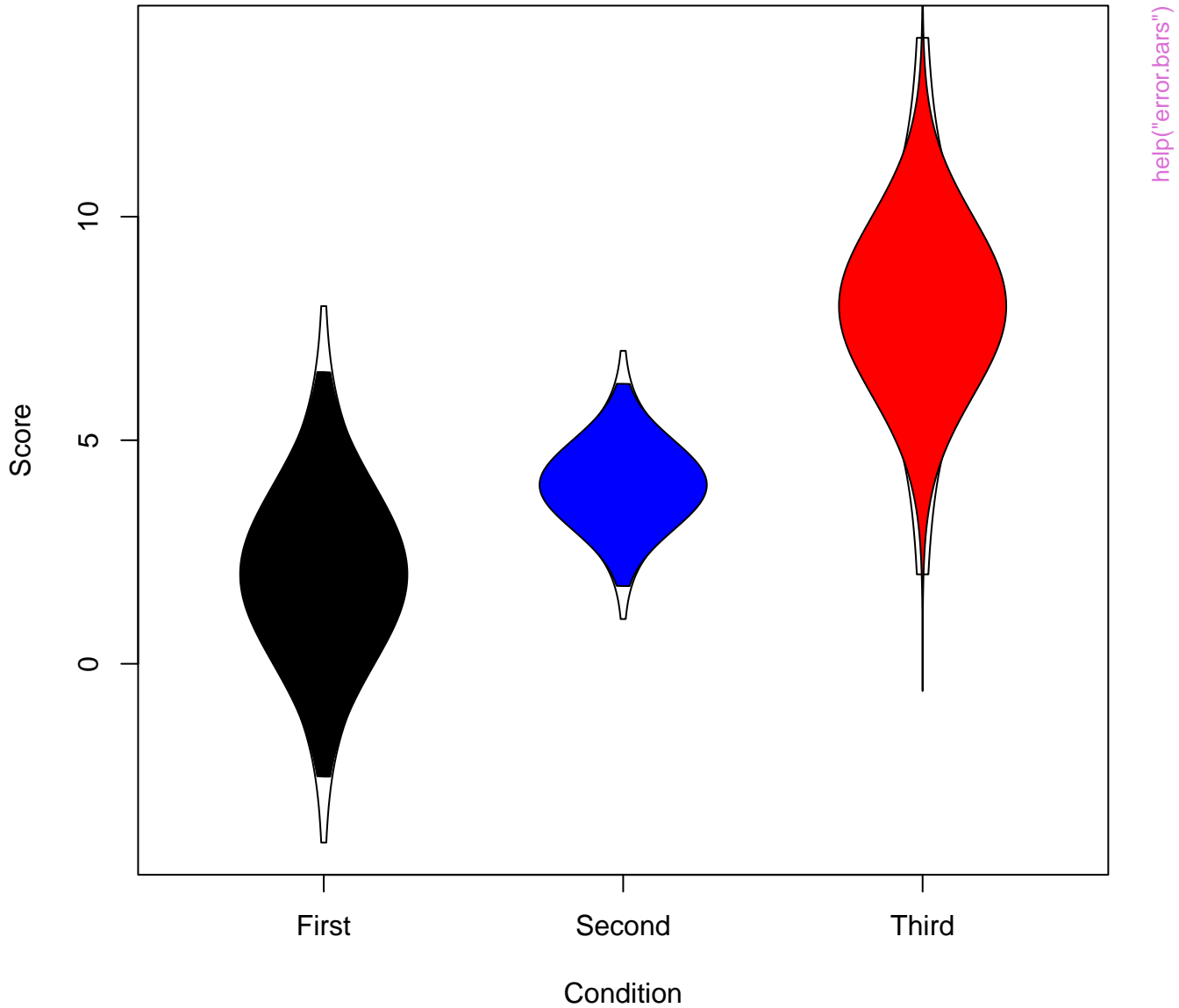

help("error bars")

Probability of Arrest varies by treatment

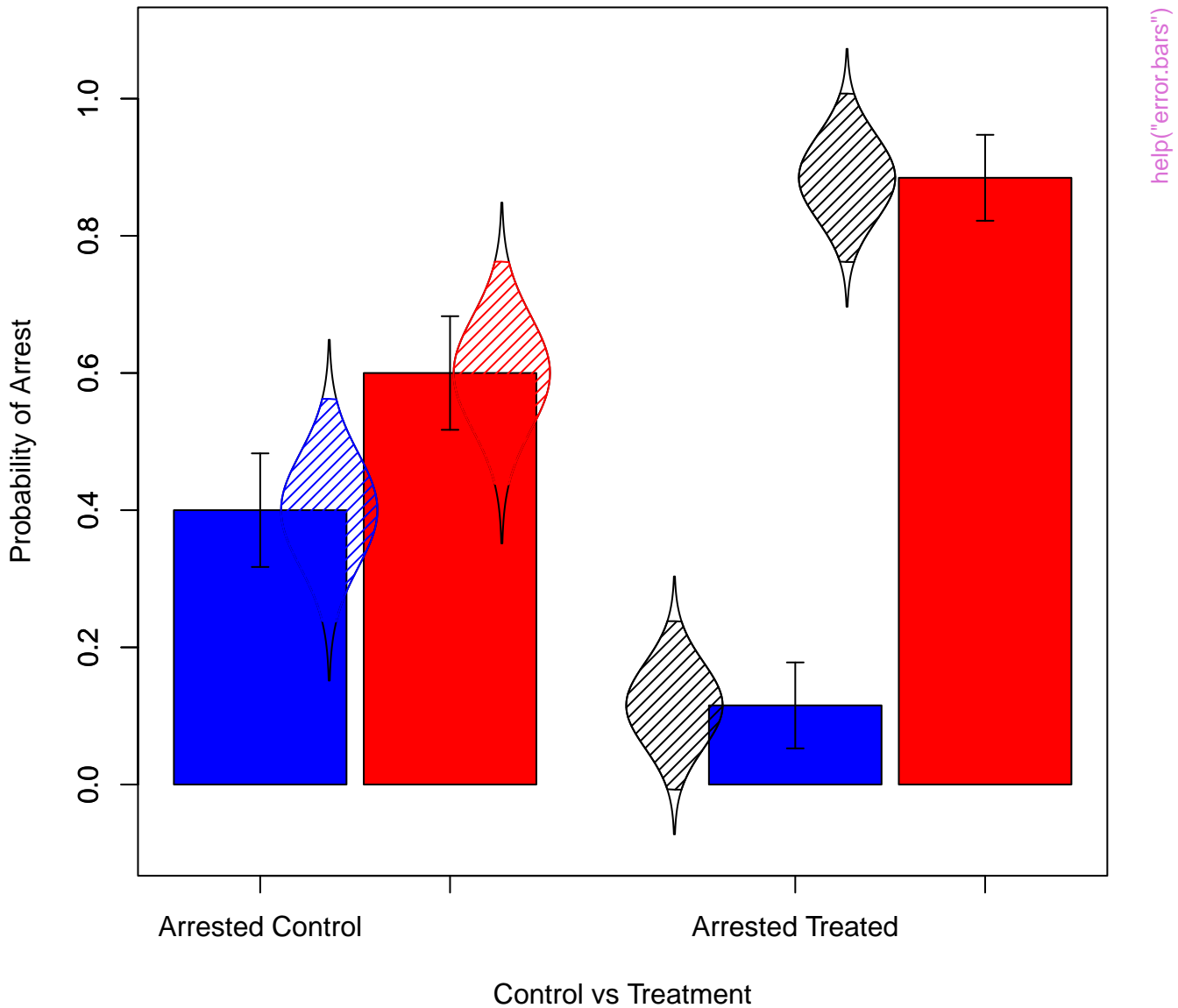

Count of Arrest varies by treatment

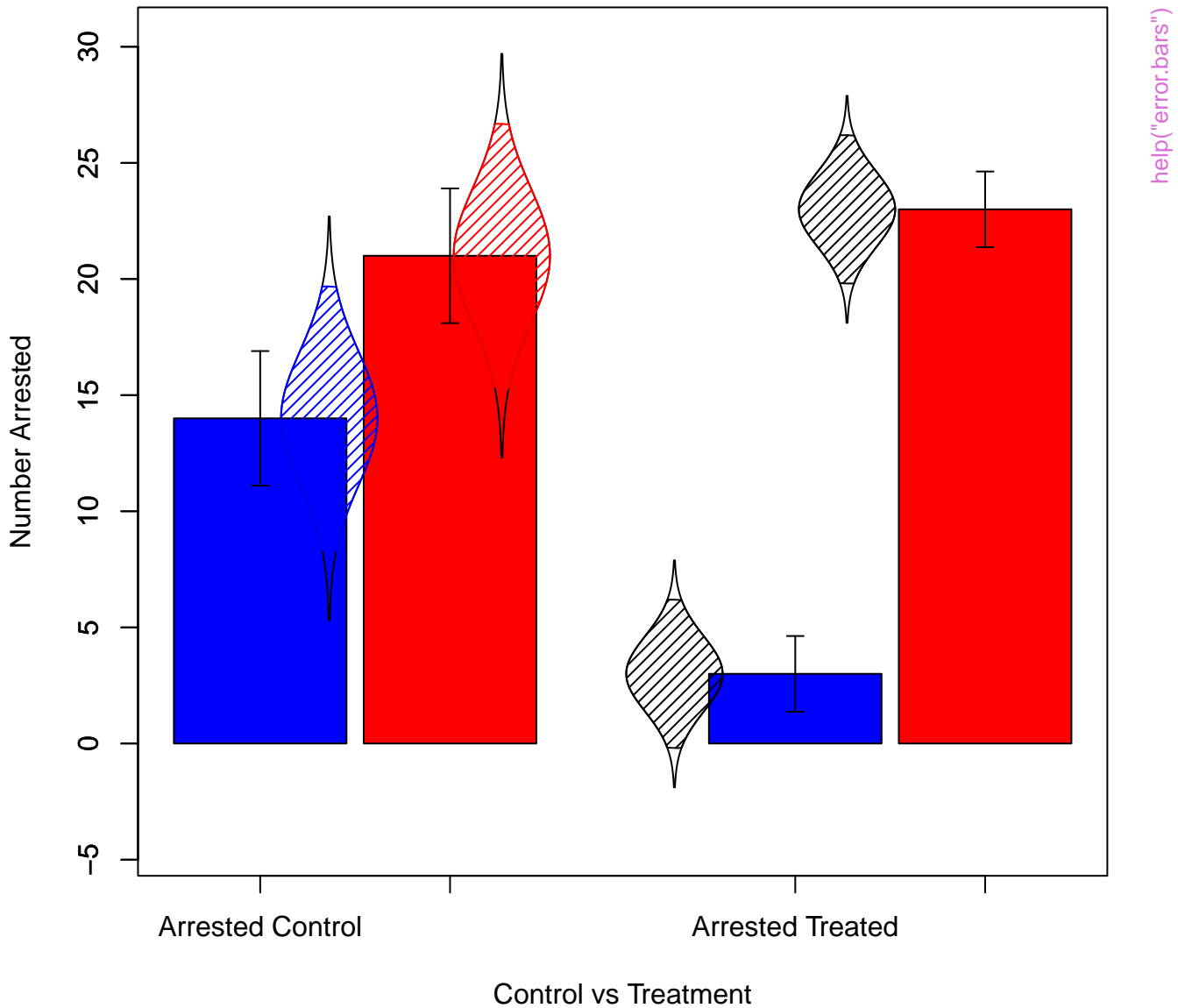

95% confidence limits

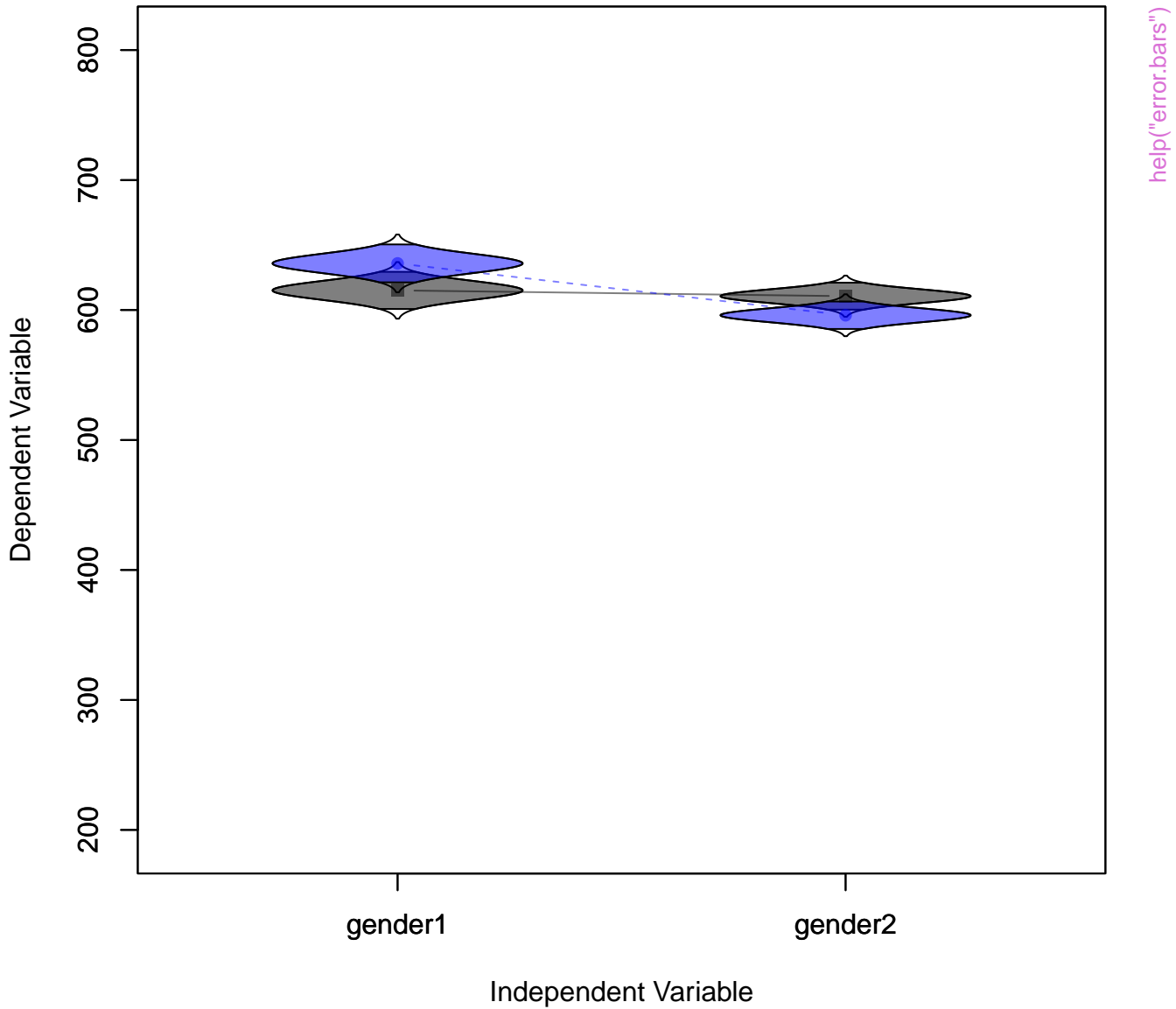

95% confidence limits

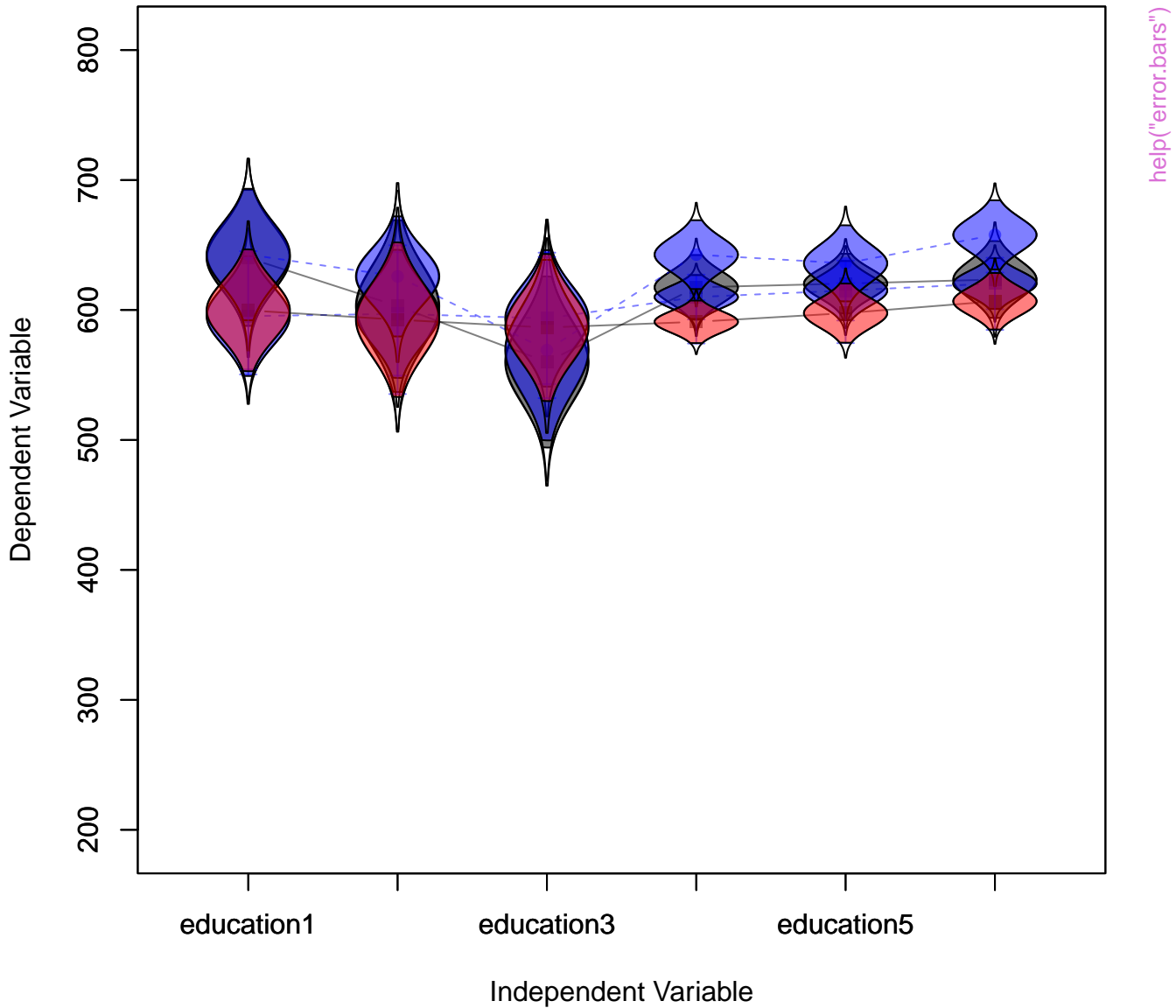

95% confidence limits

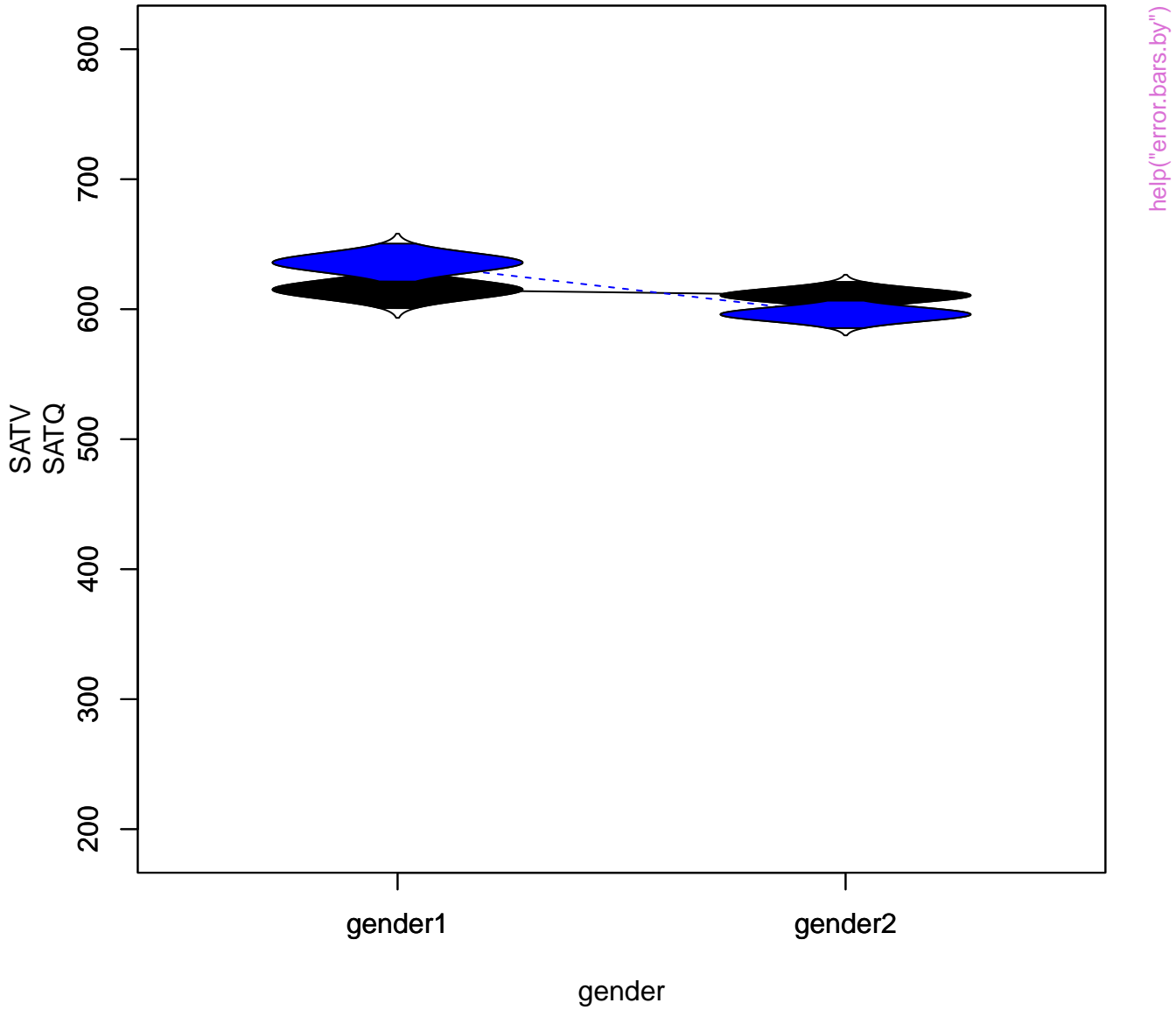

95% confidence limits

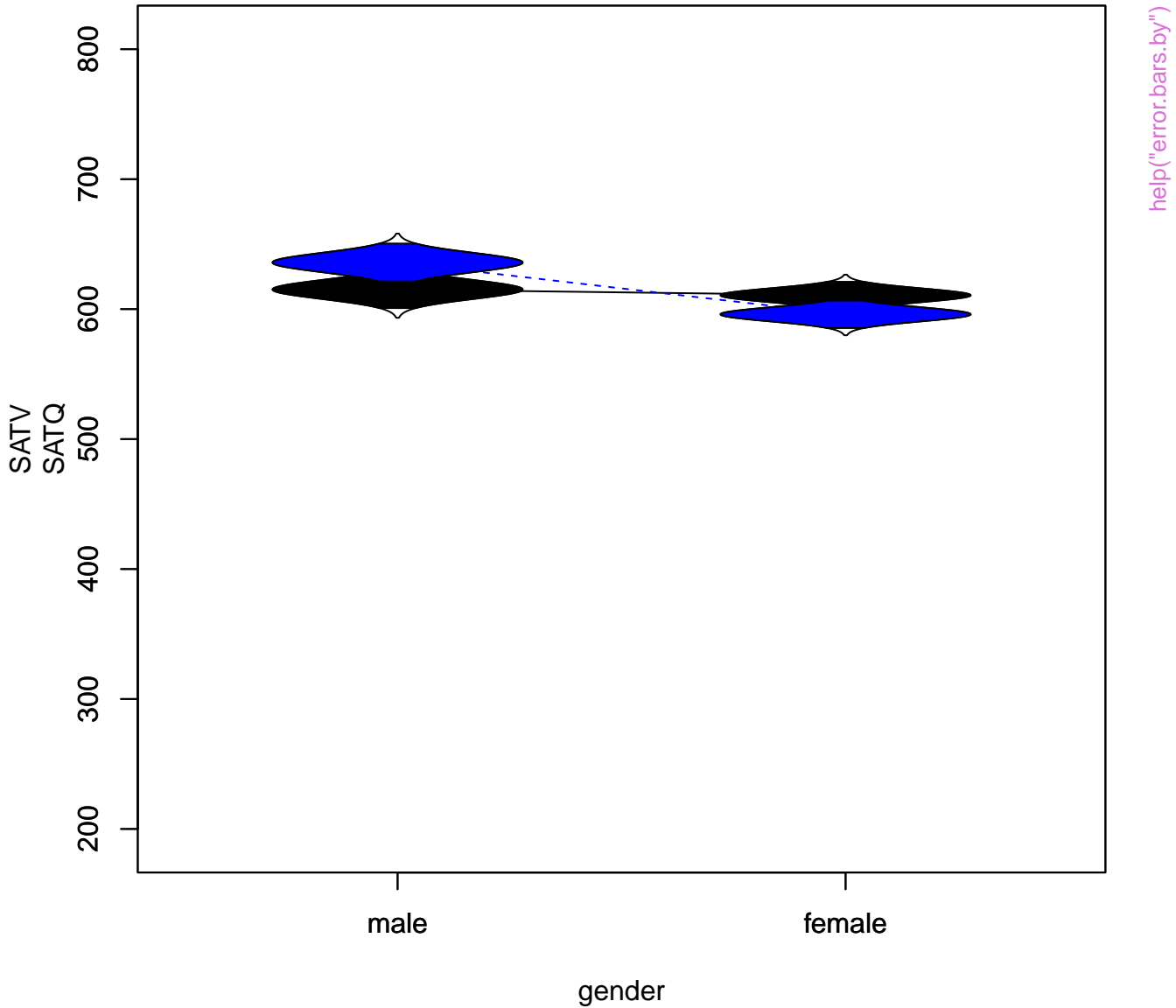

help("error.bars.by")

95% confidence limits

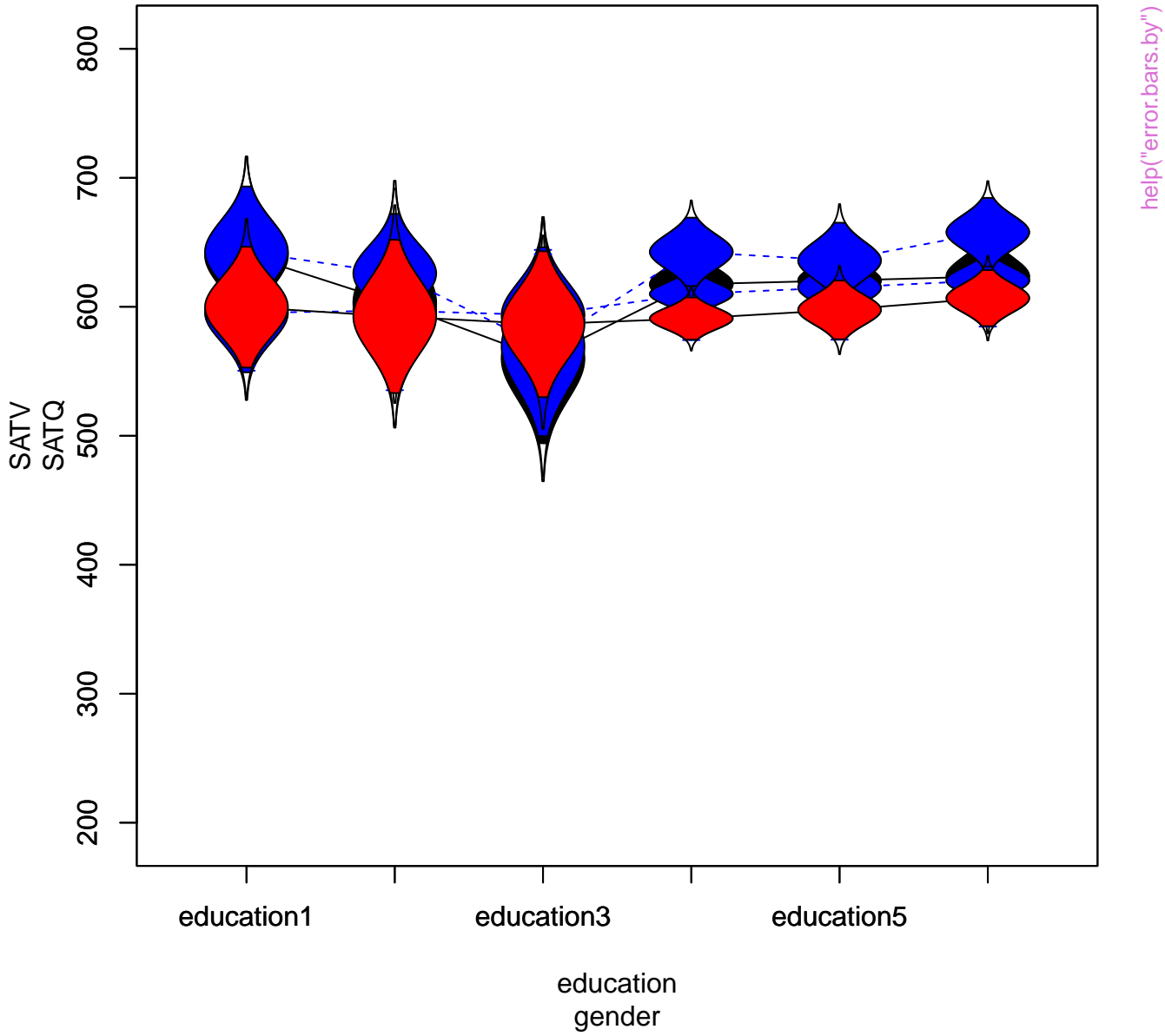

help("error.bars.by")

95% confidence limits

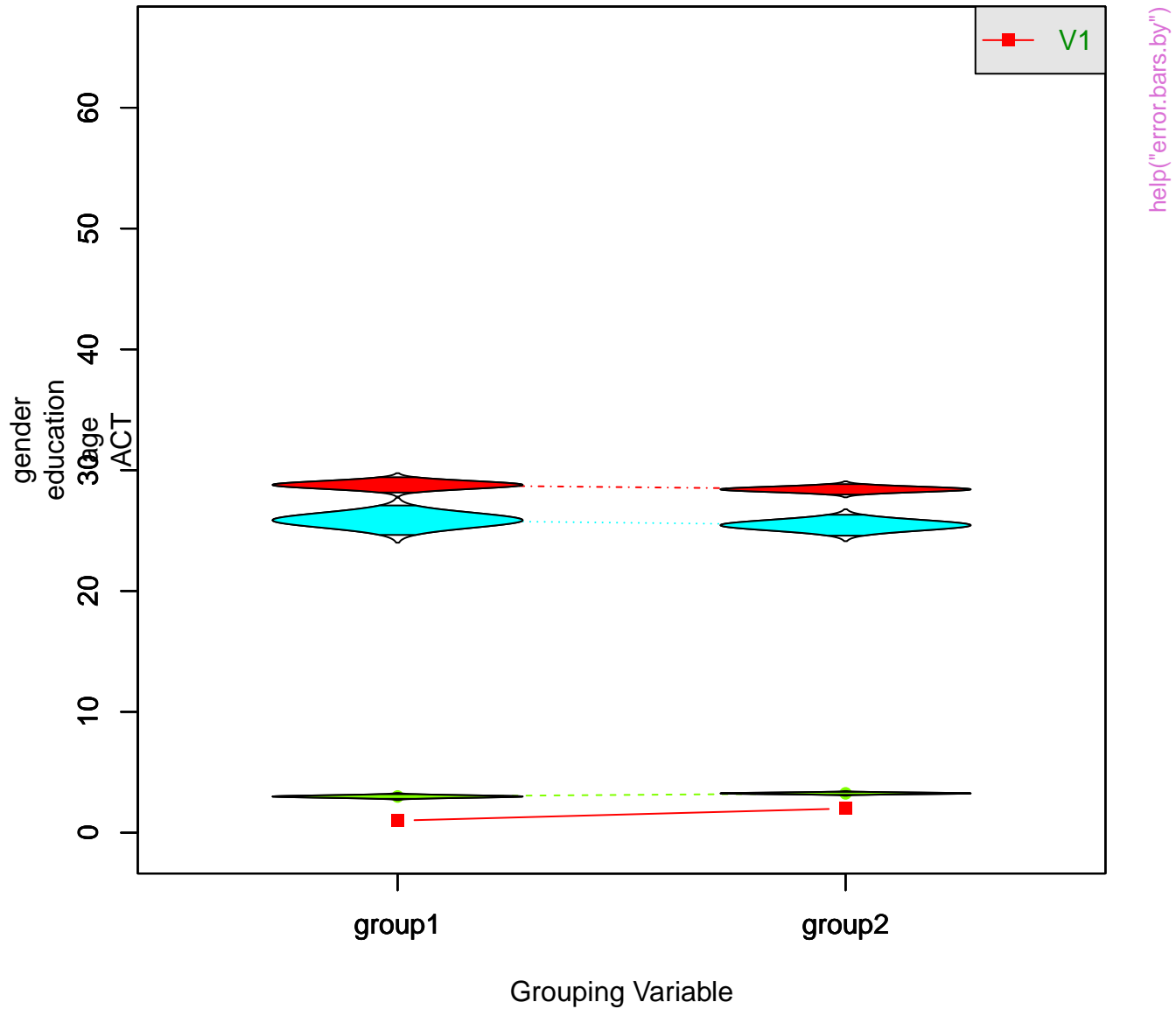

95% confidence limits

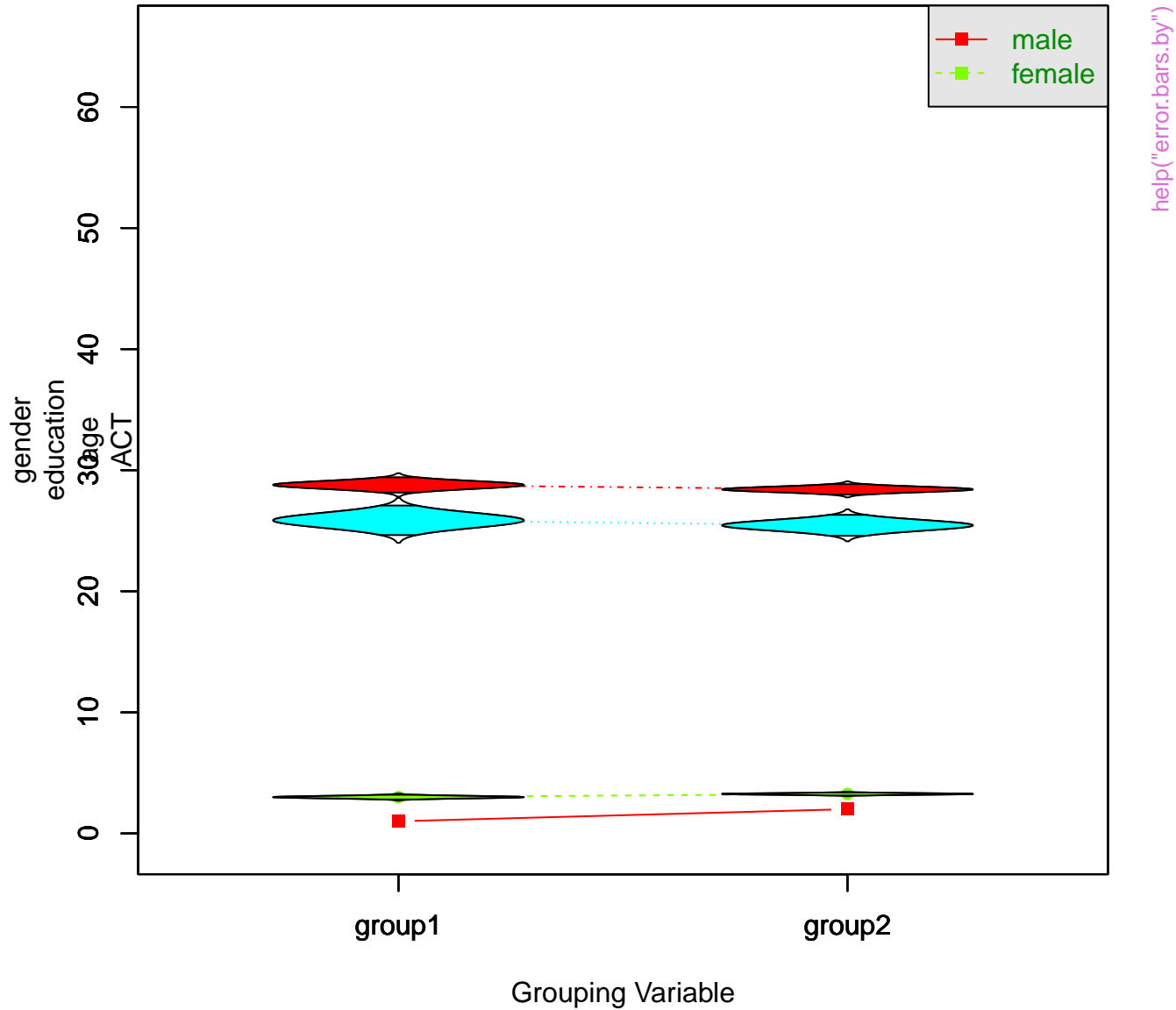

SAT V and SAT Q by gender

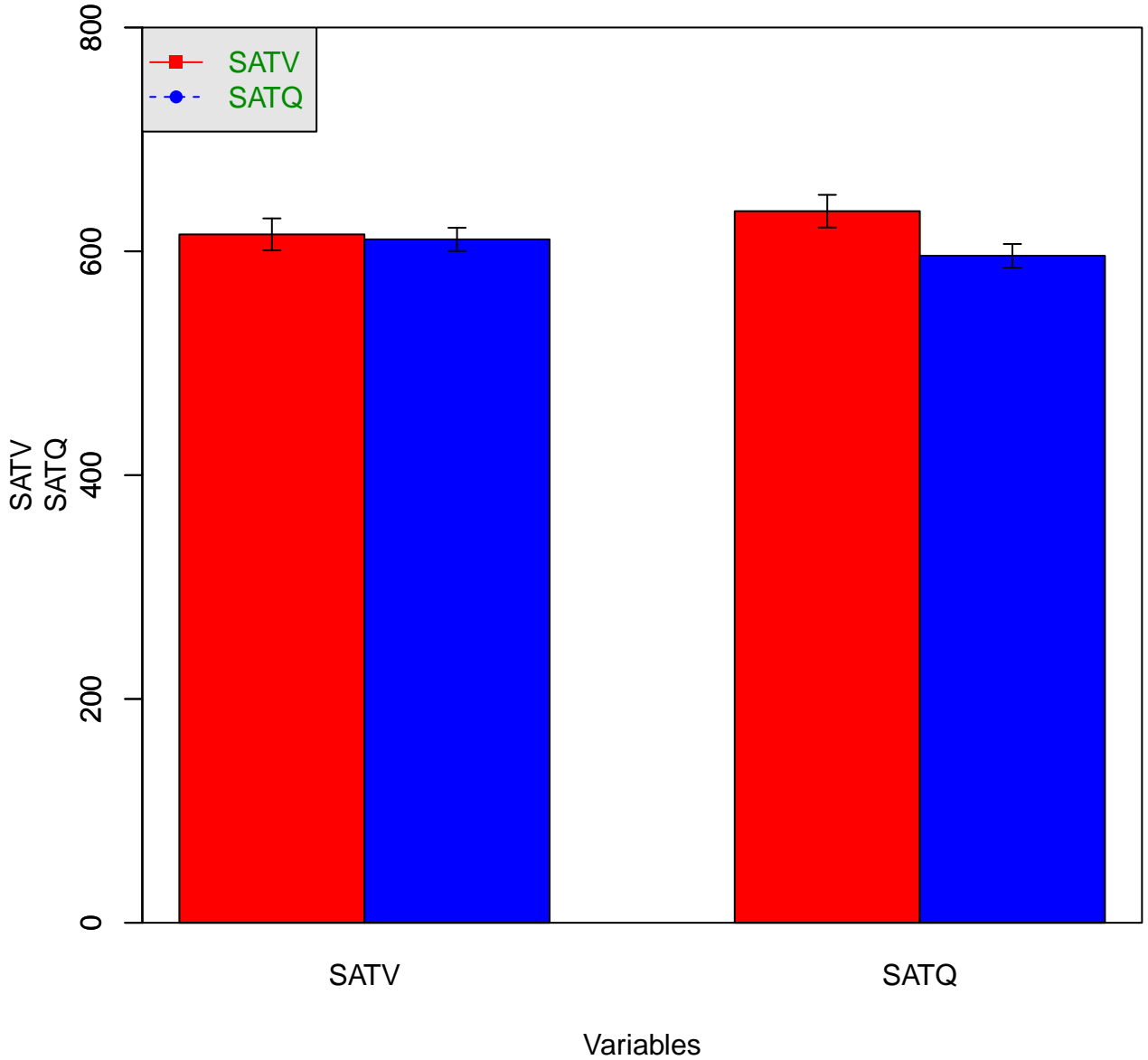

help("error.bars.by")

95 percent confidence limits of Sat V and Sat Q

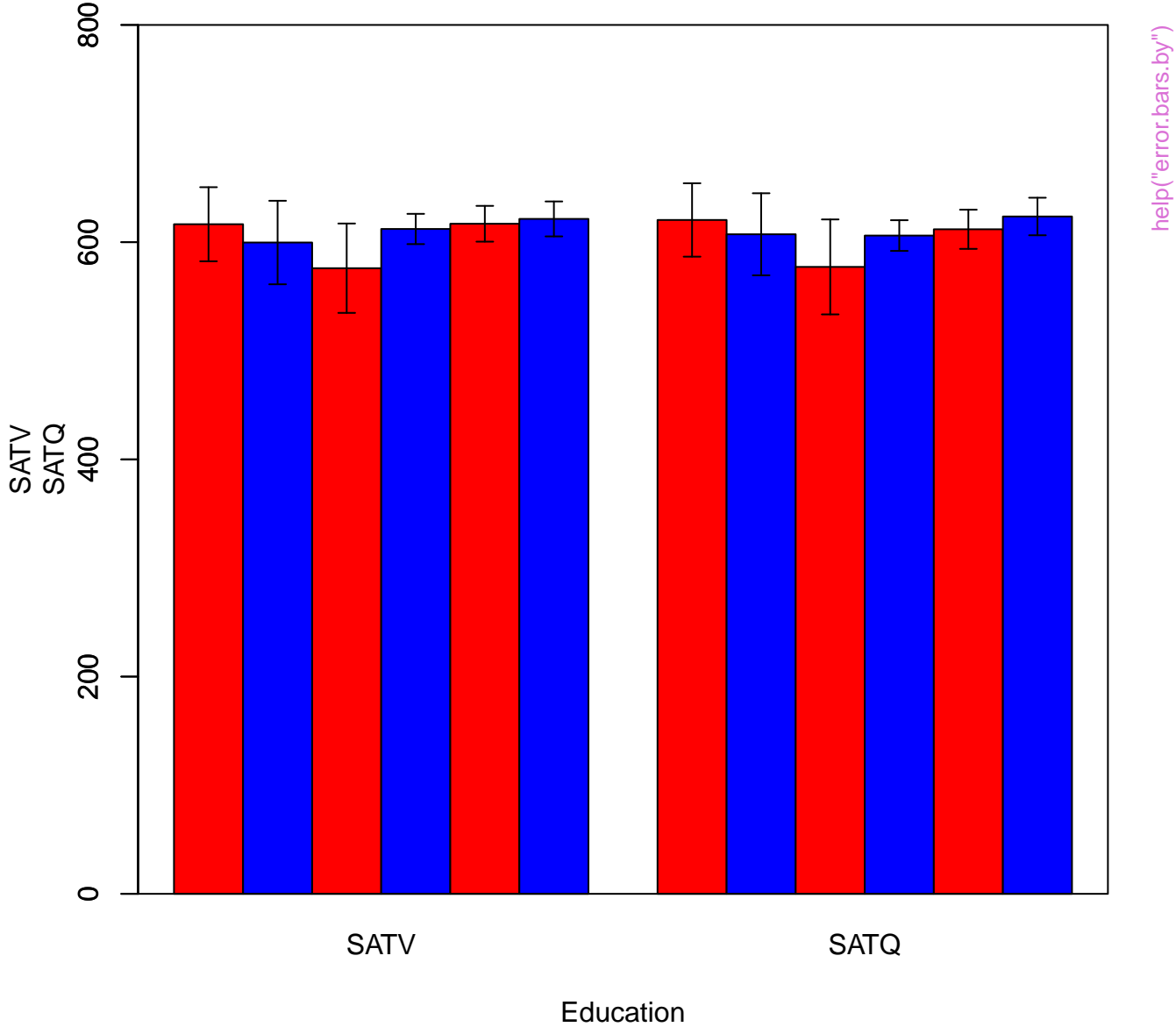

self reported SAT scores by education

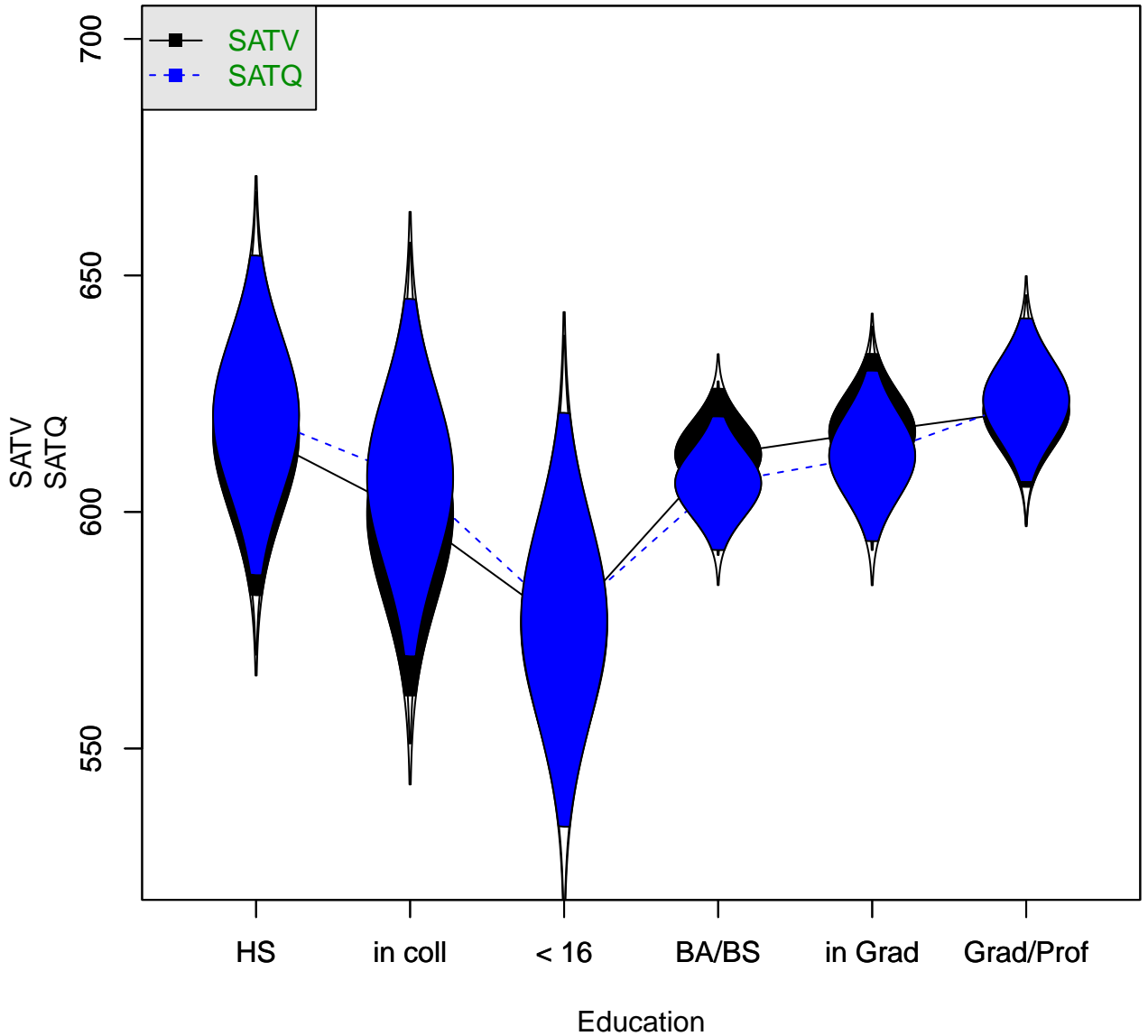

help("error.bars.by")

self reported SAT scores by education

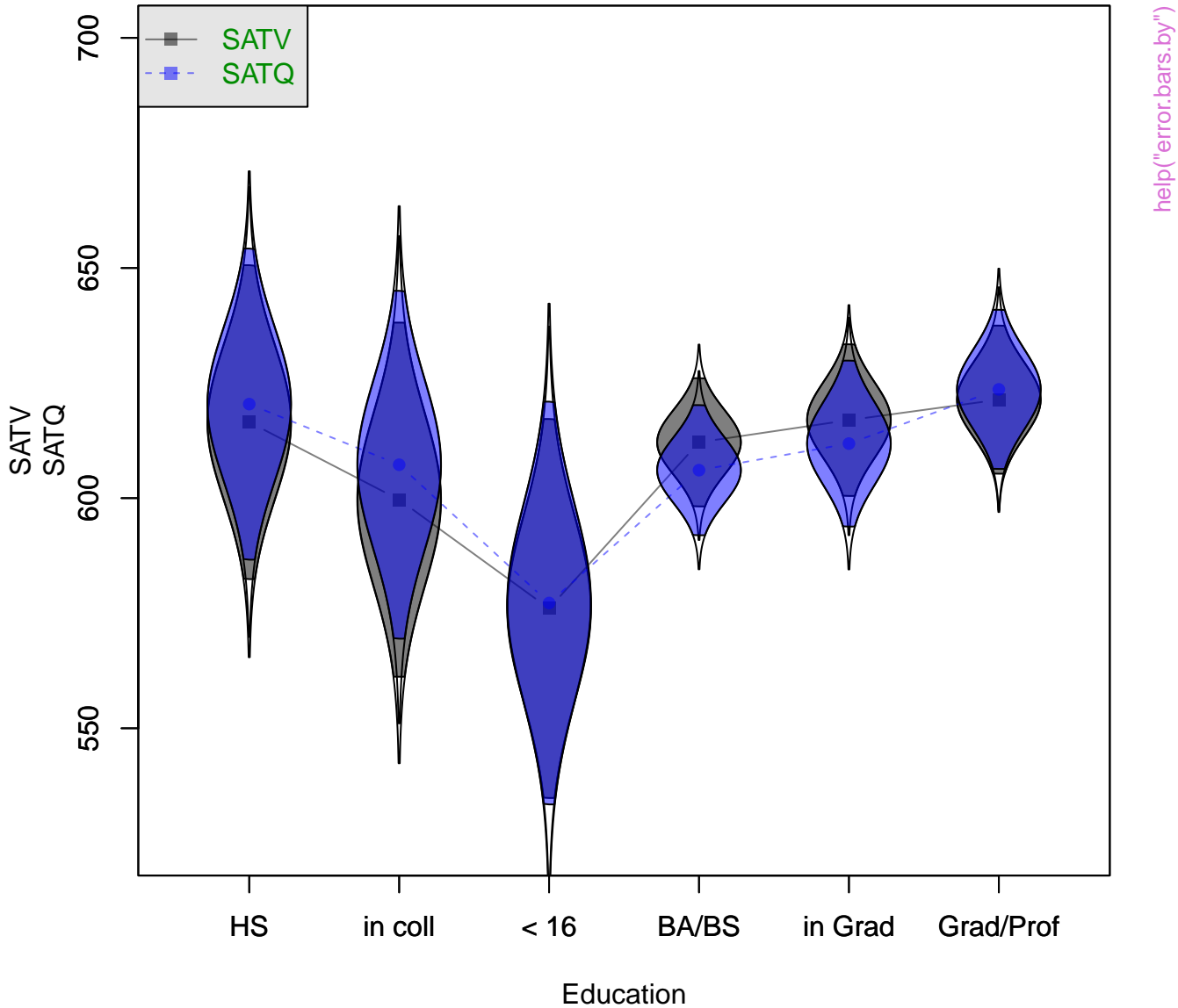

help("error.bars.by")

self reported SAT scores by education

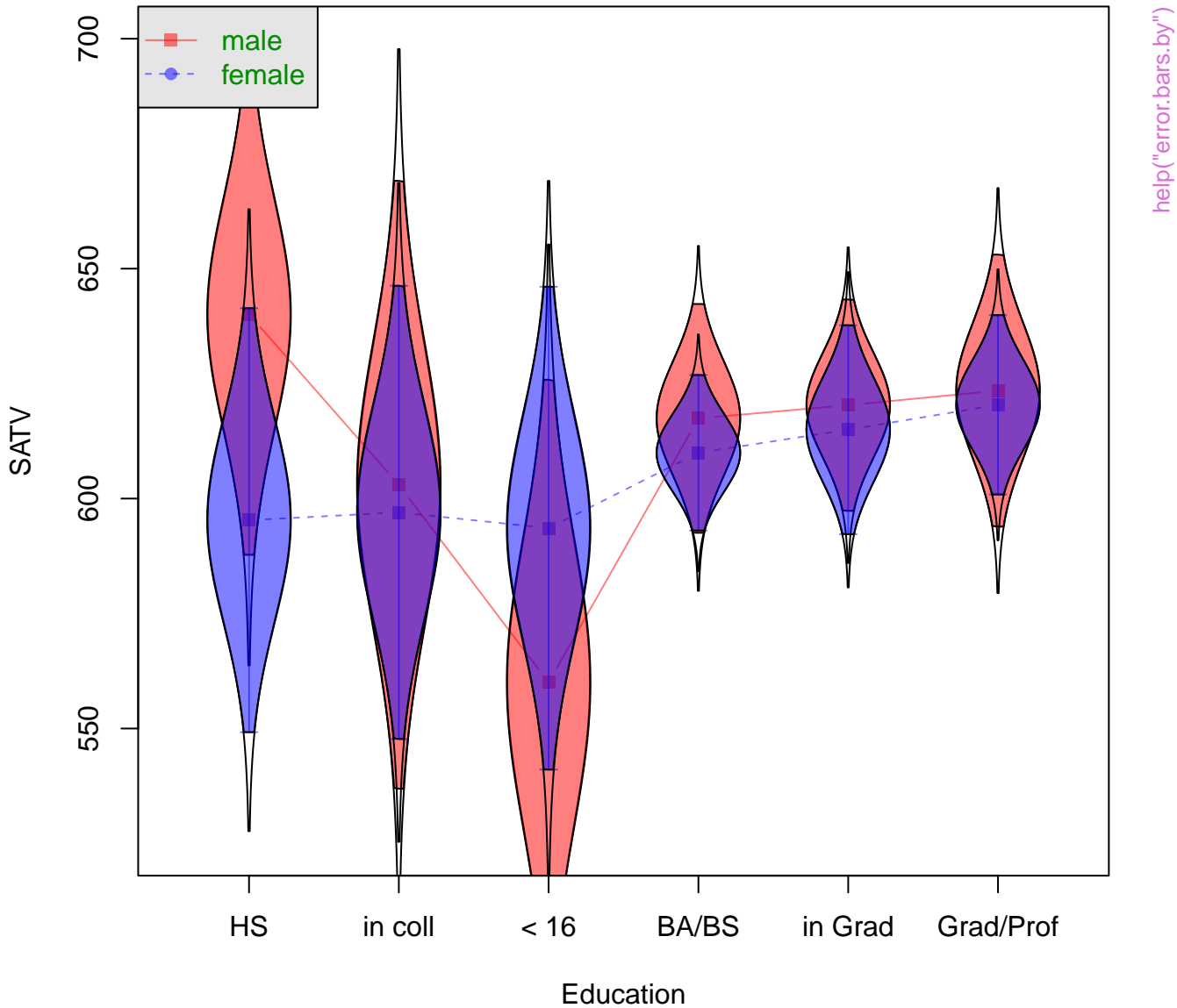

help("error.bars.by")

BFI age trends

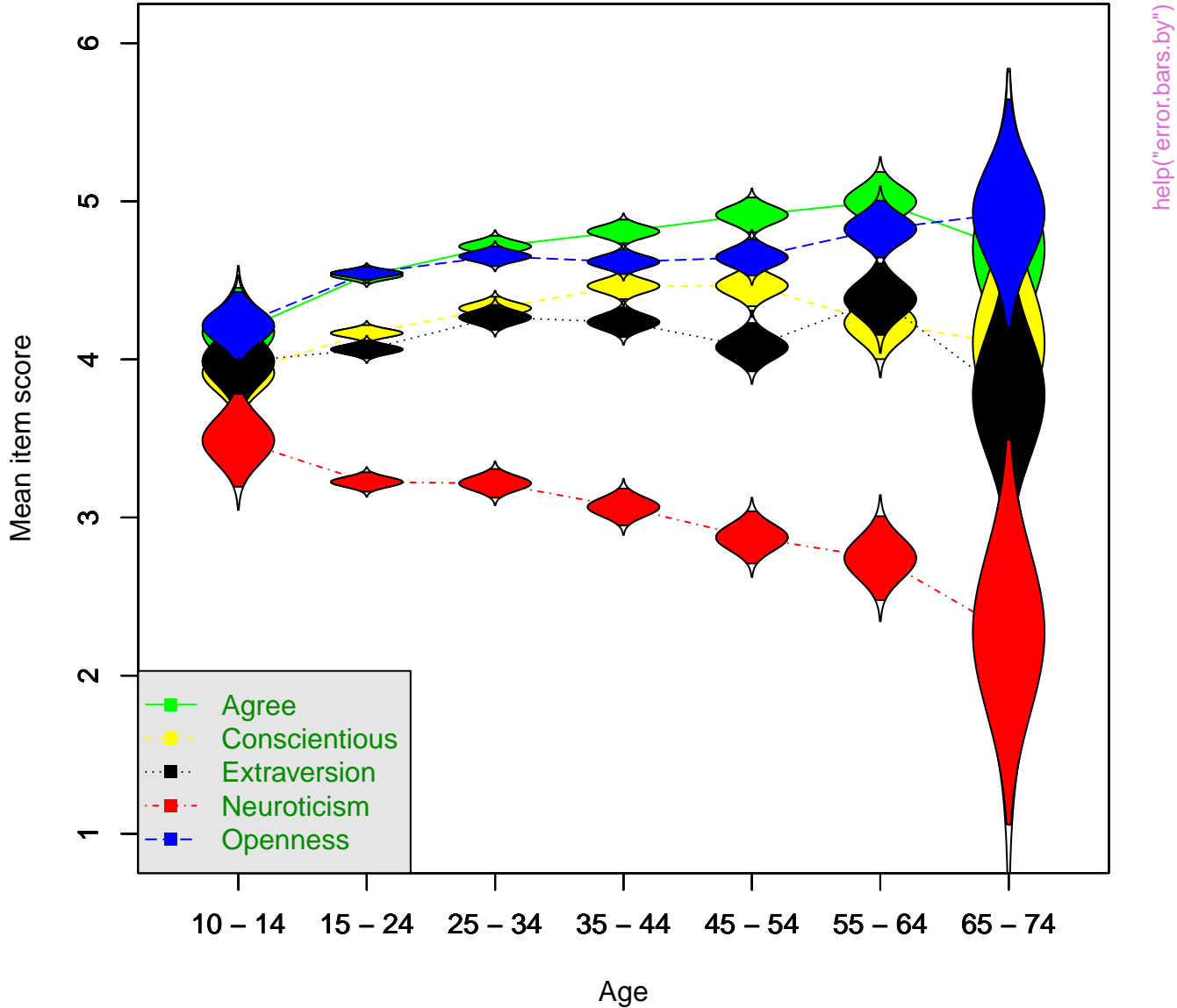

help("error.bars.by")

BFI age trends

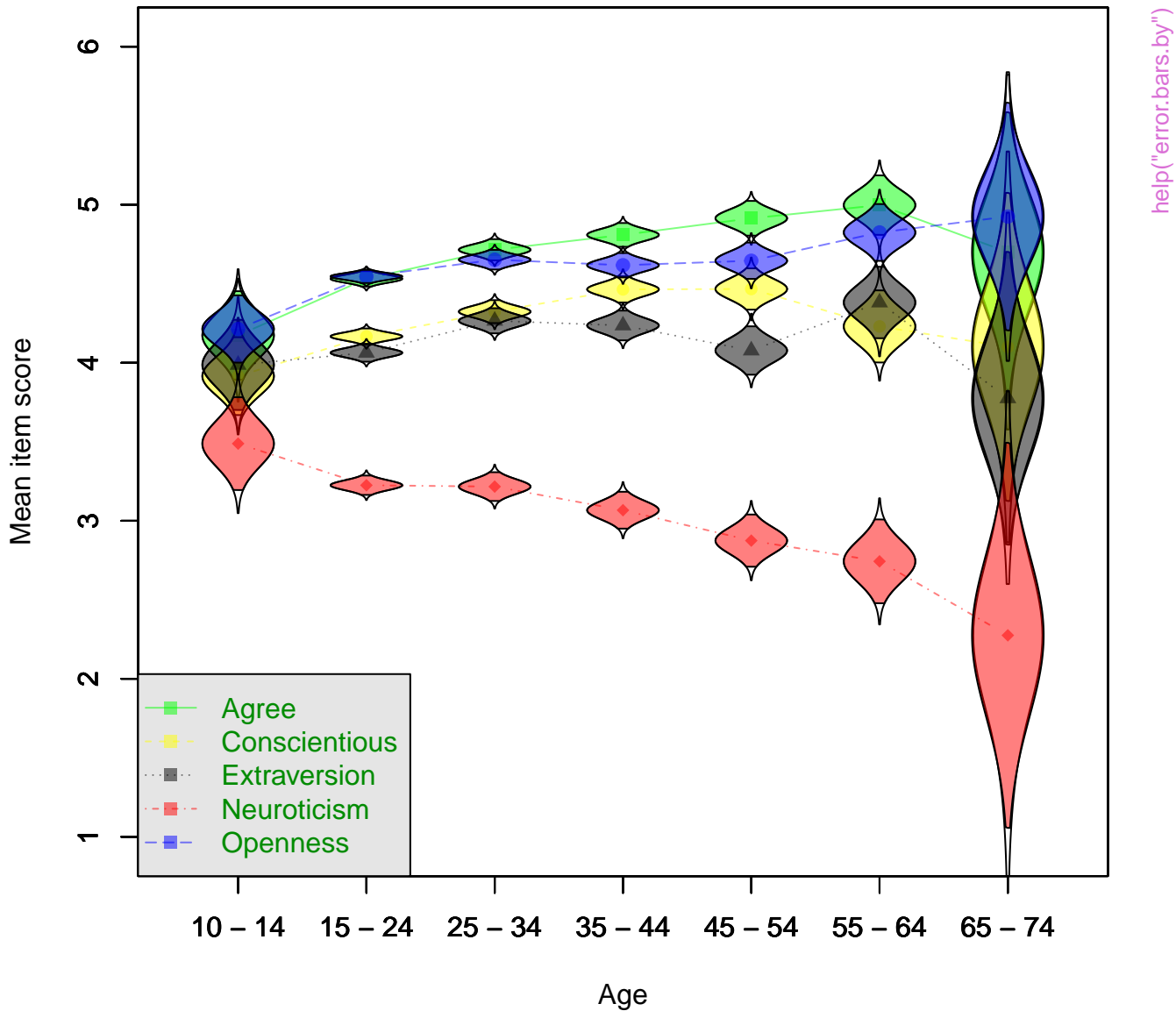

BFI scores by gender

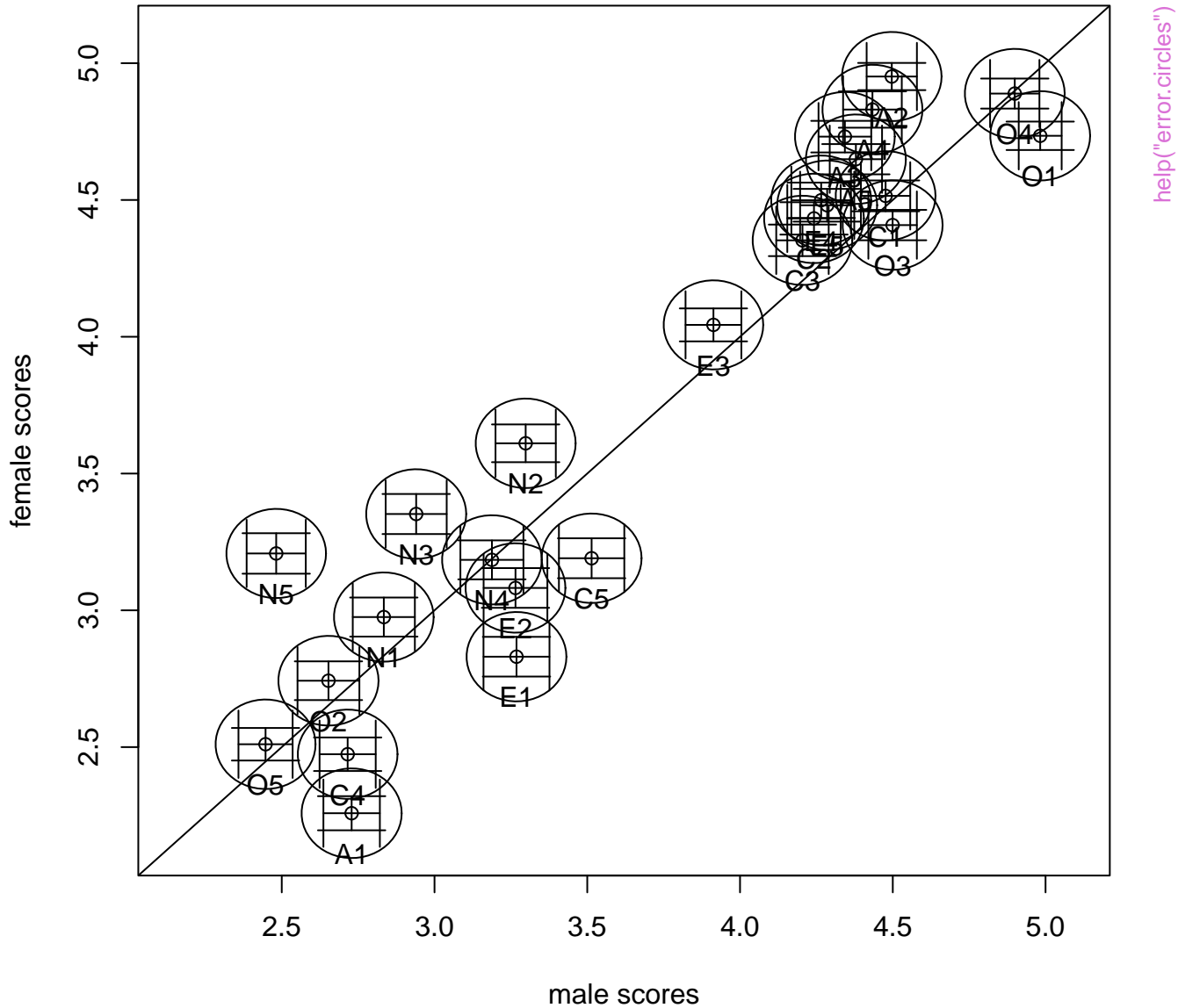

help("error.circles")

BFI scores by gender

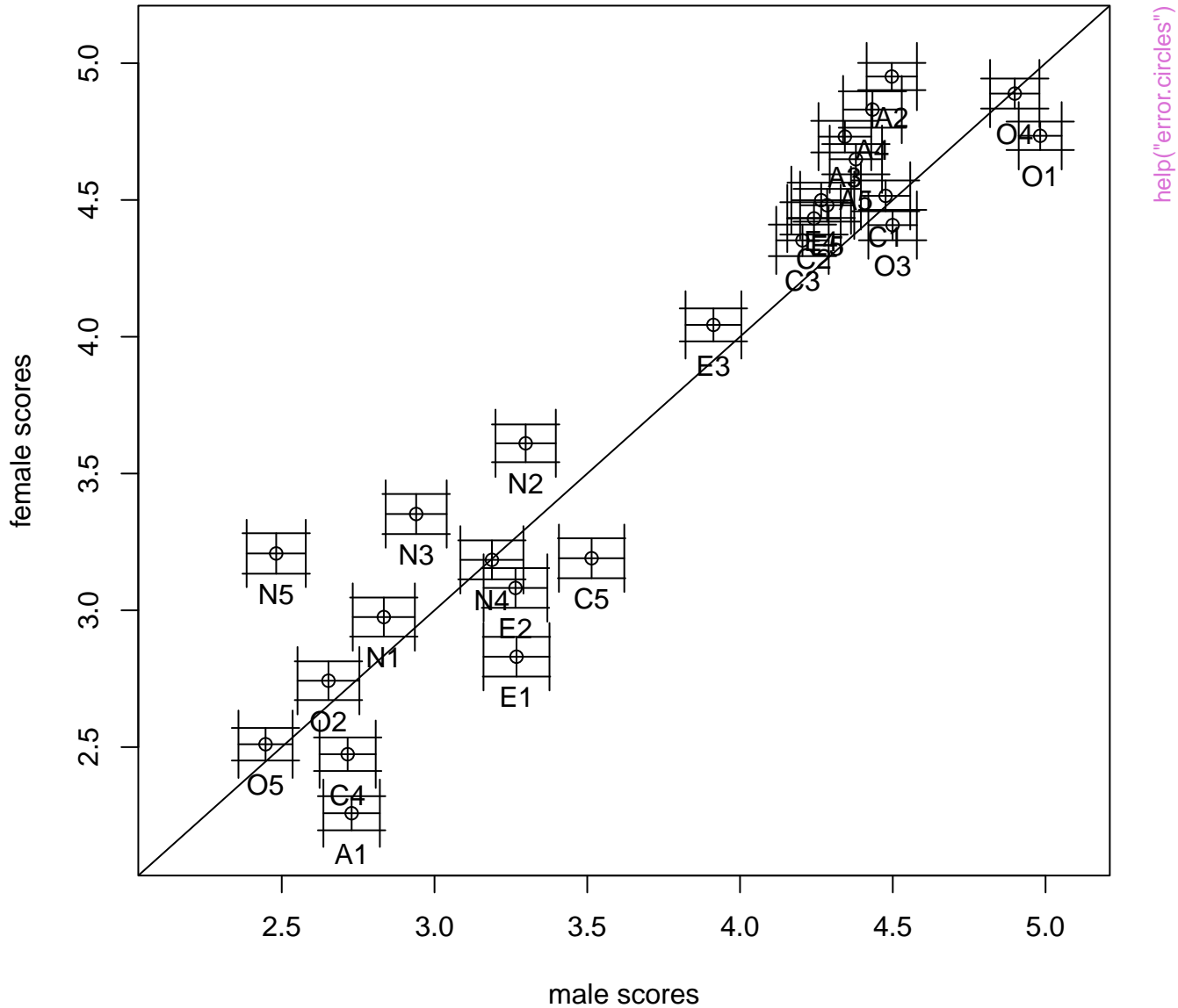

help("error.circles")

EA and TA pre and post affective movies

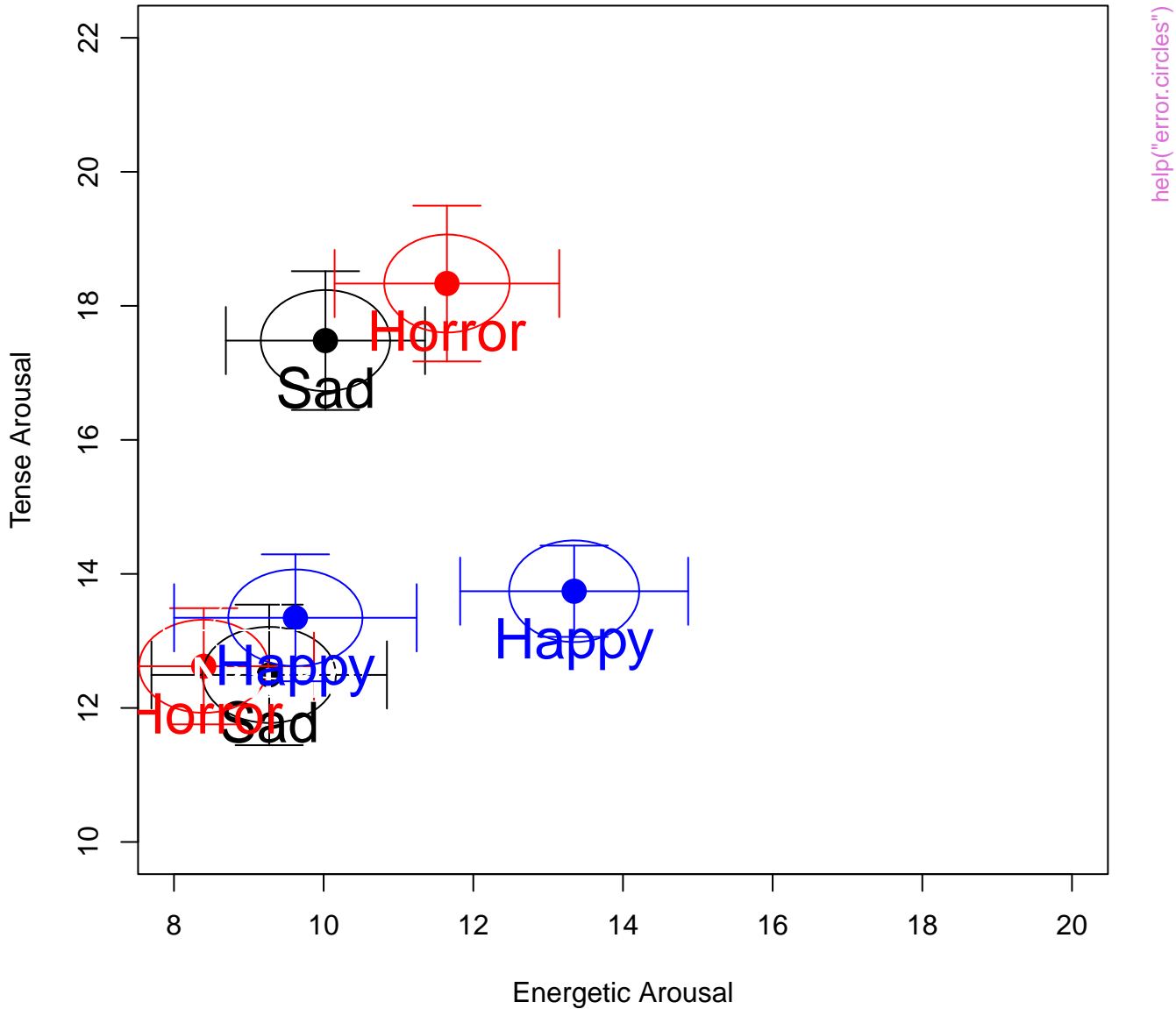

95% confidence limits

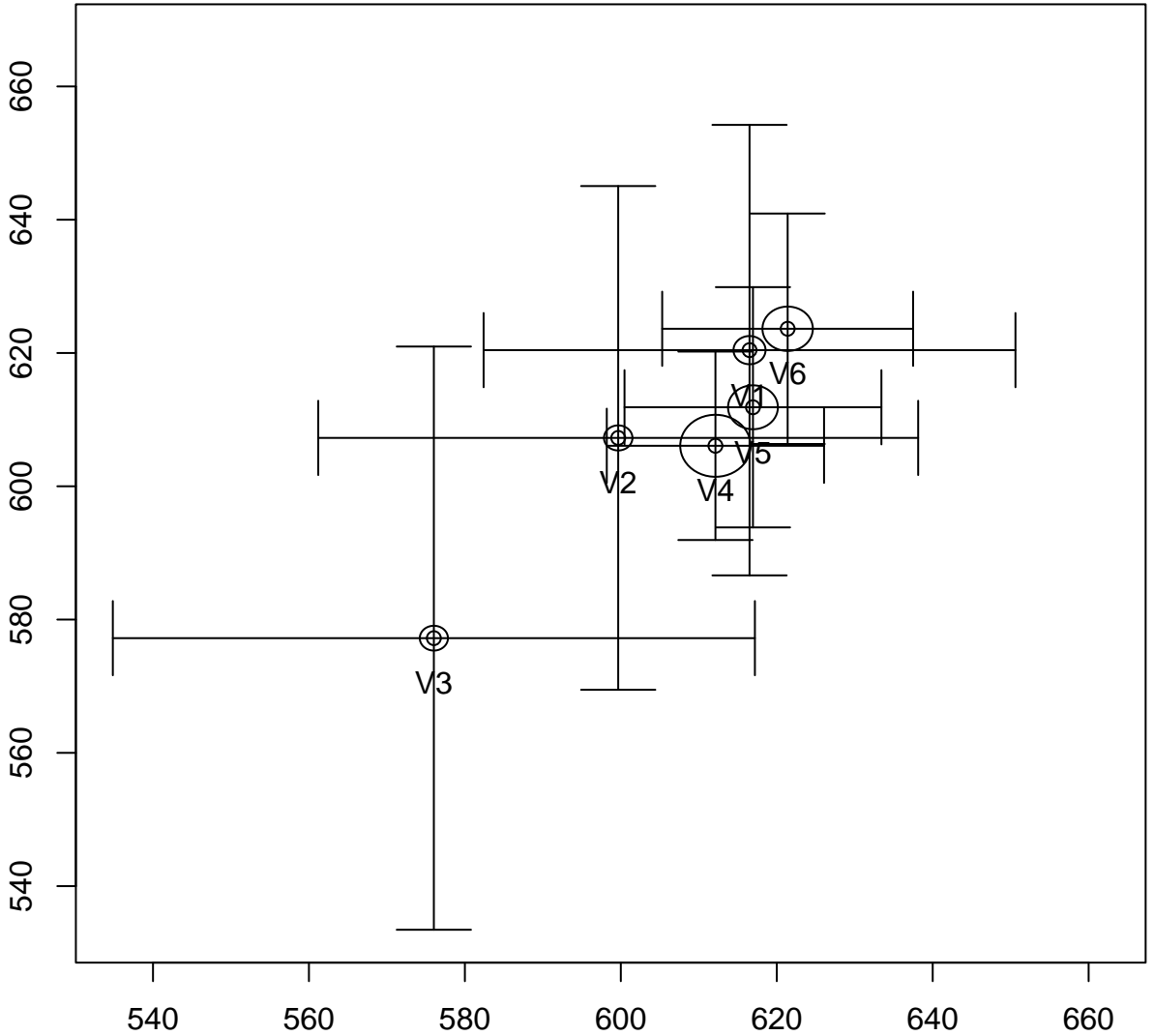

help("error.circles")

SATV by education

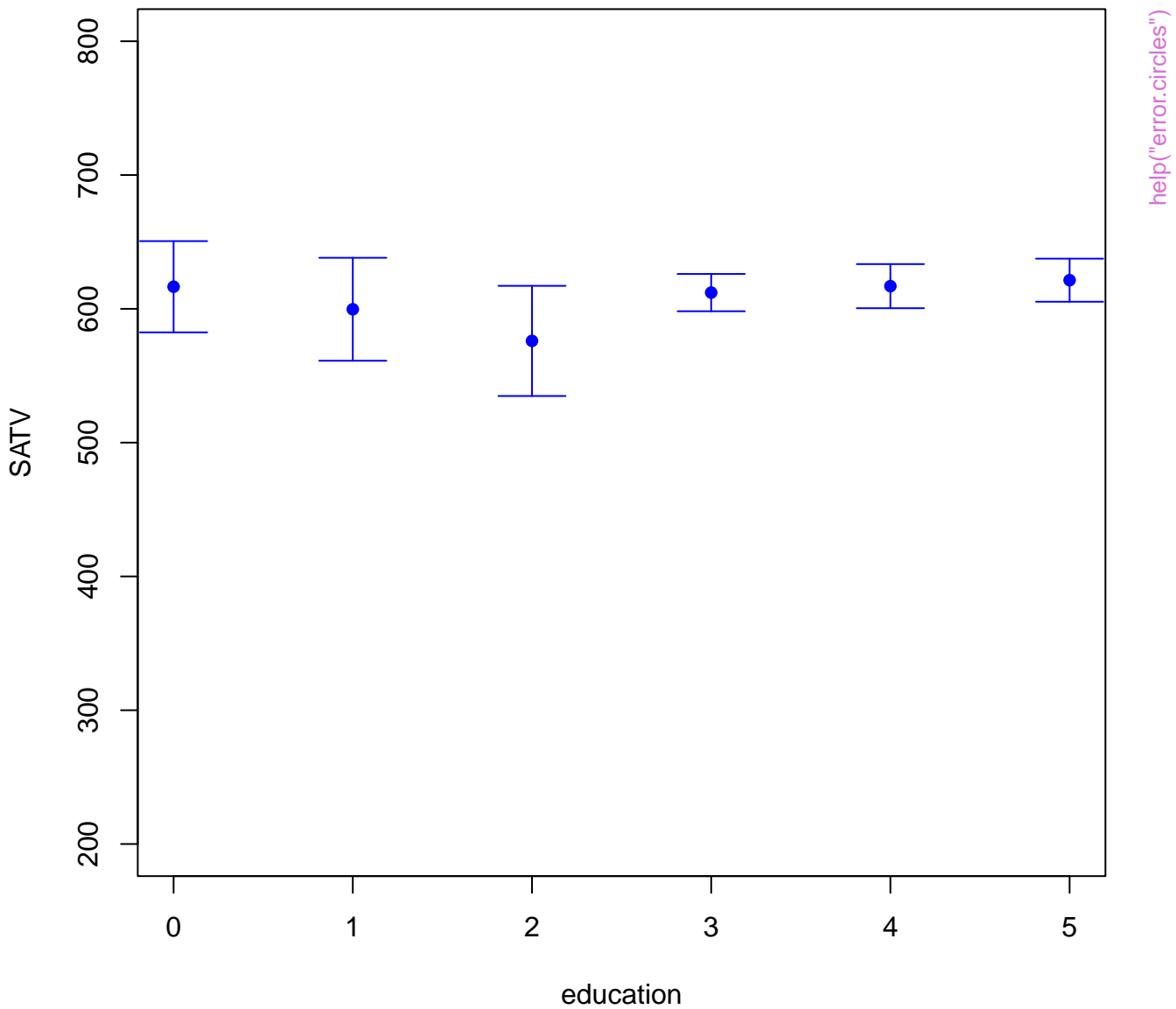

95% confidence limits

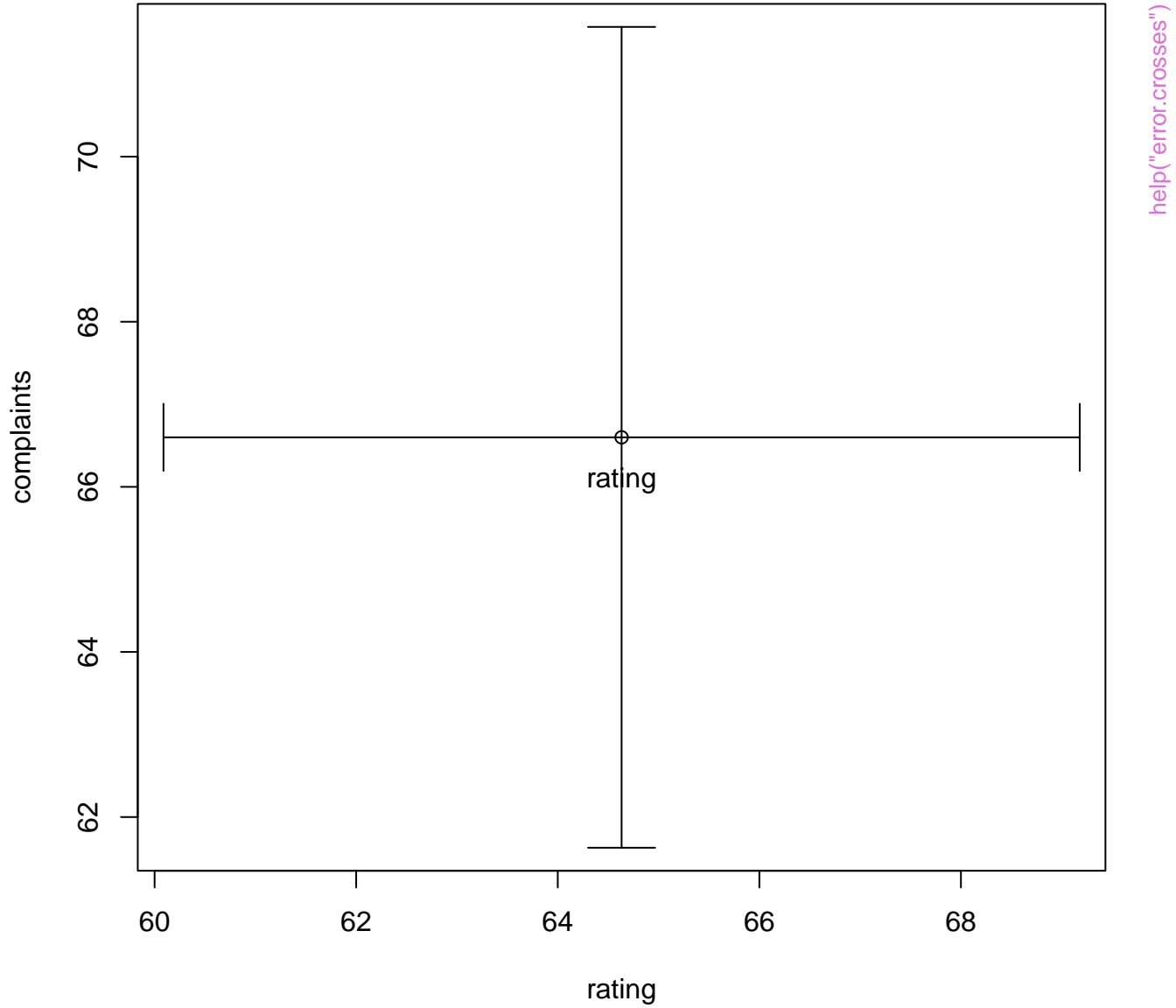

help("error.crosses")

BFI scores by gender

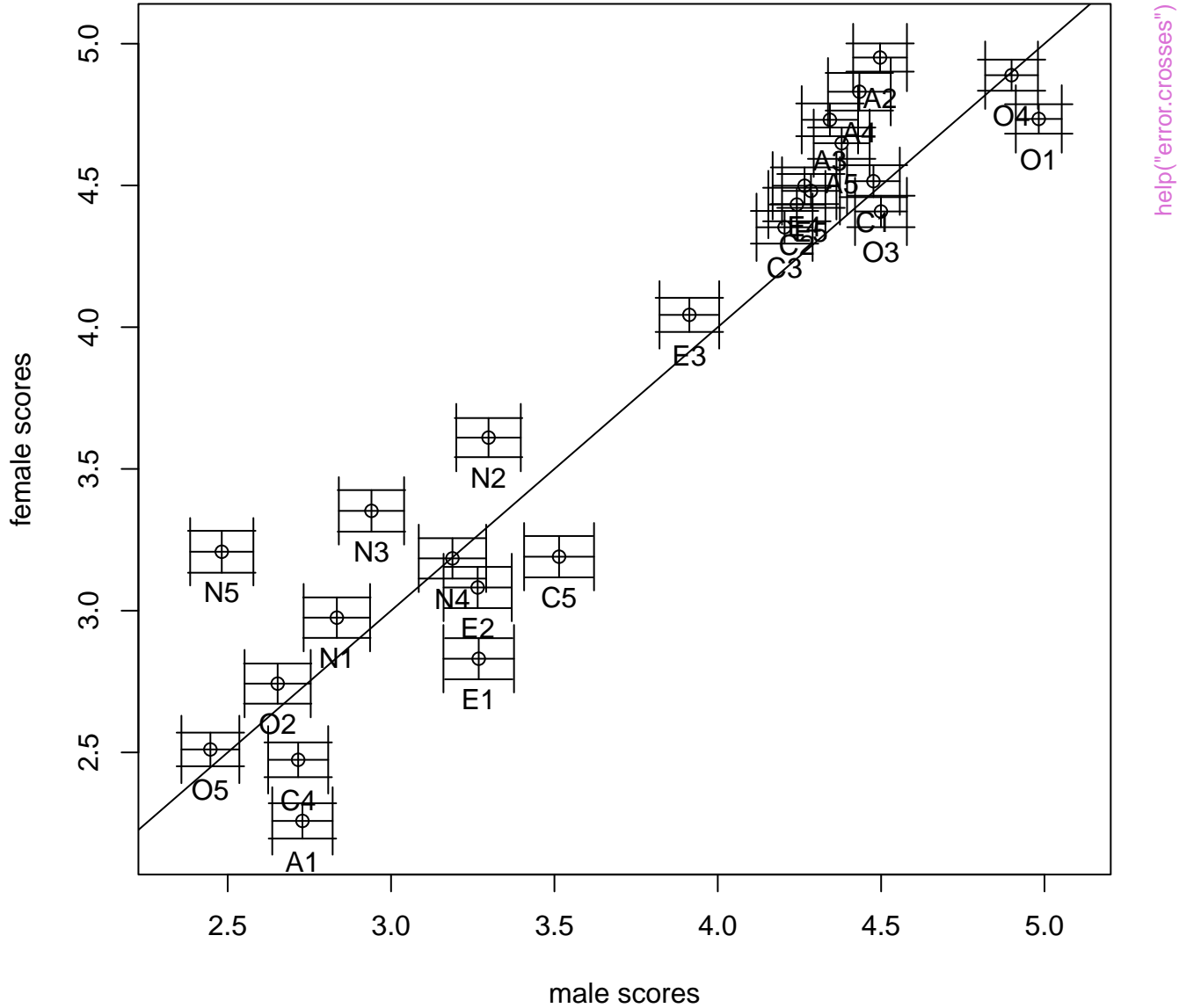

help("error.crosses")

95% confidence limits

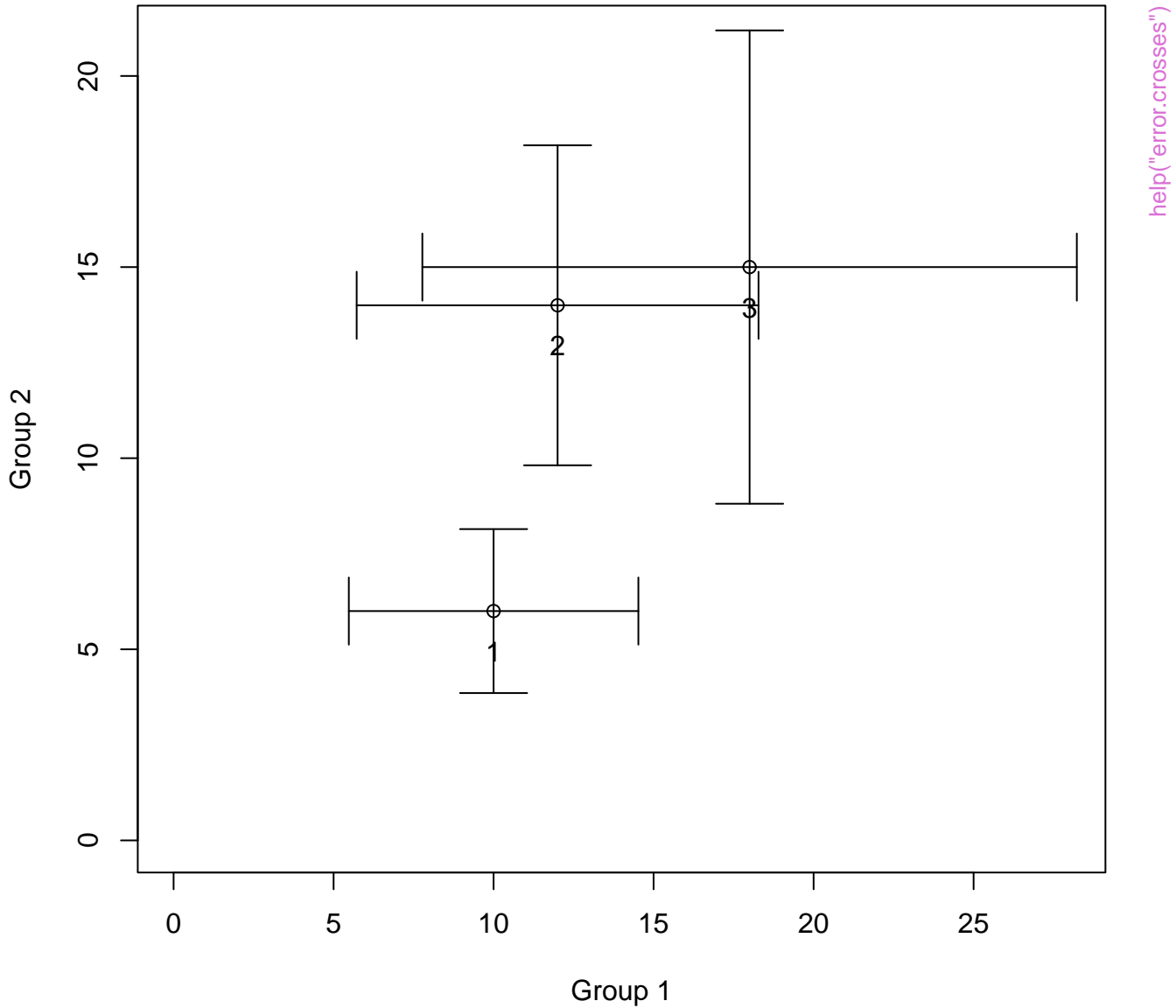

help("error.crosses")

Means and standard deviations

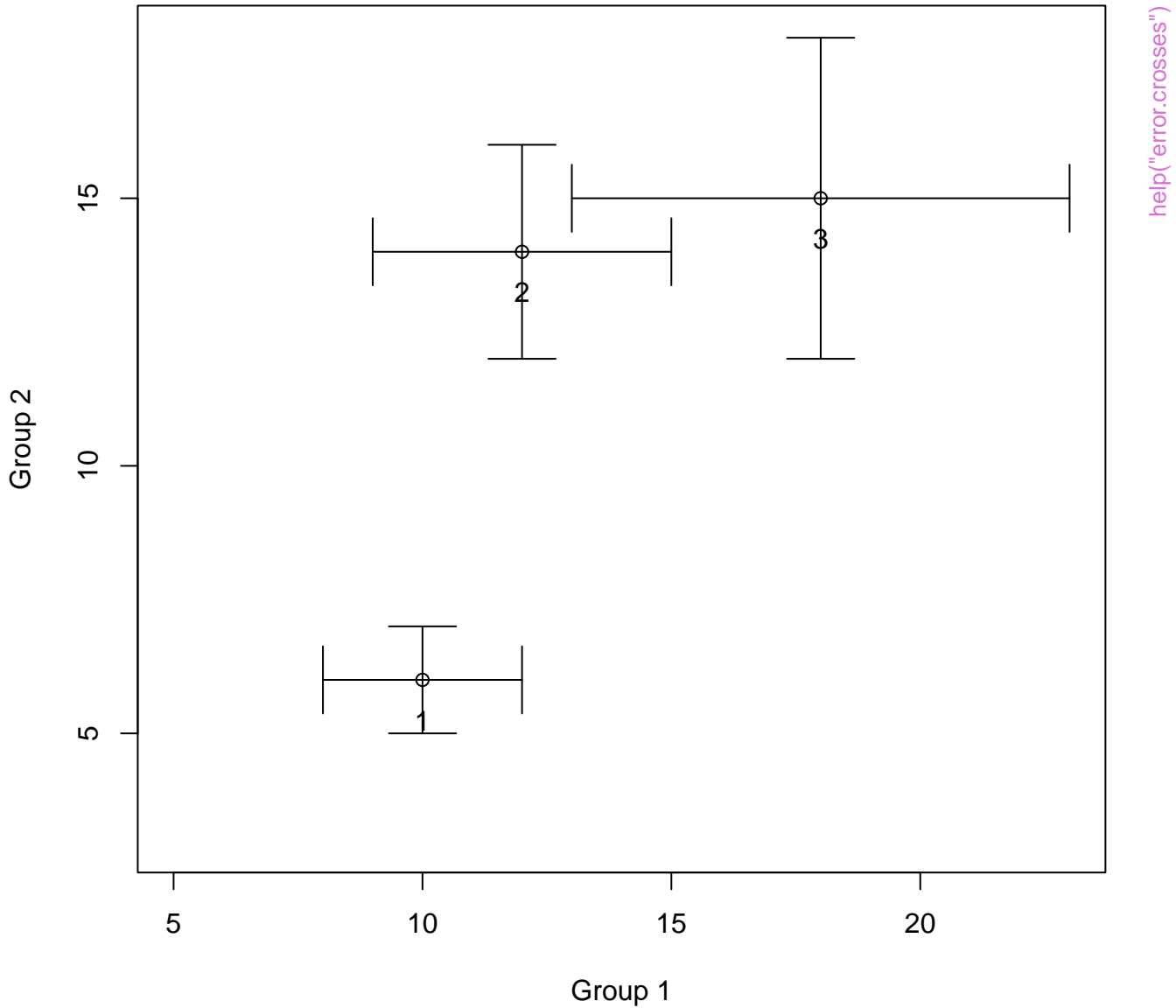

help("error.crosses")

95% confidence limits

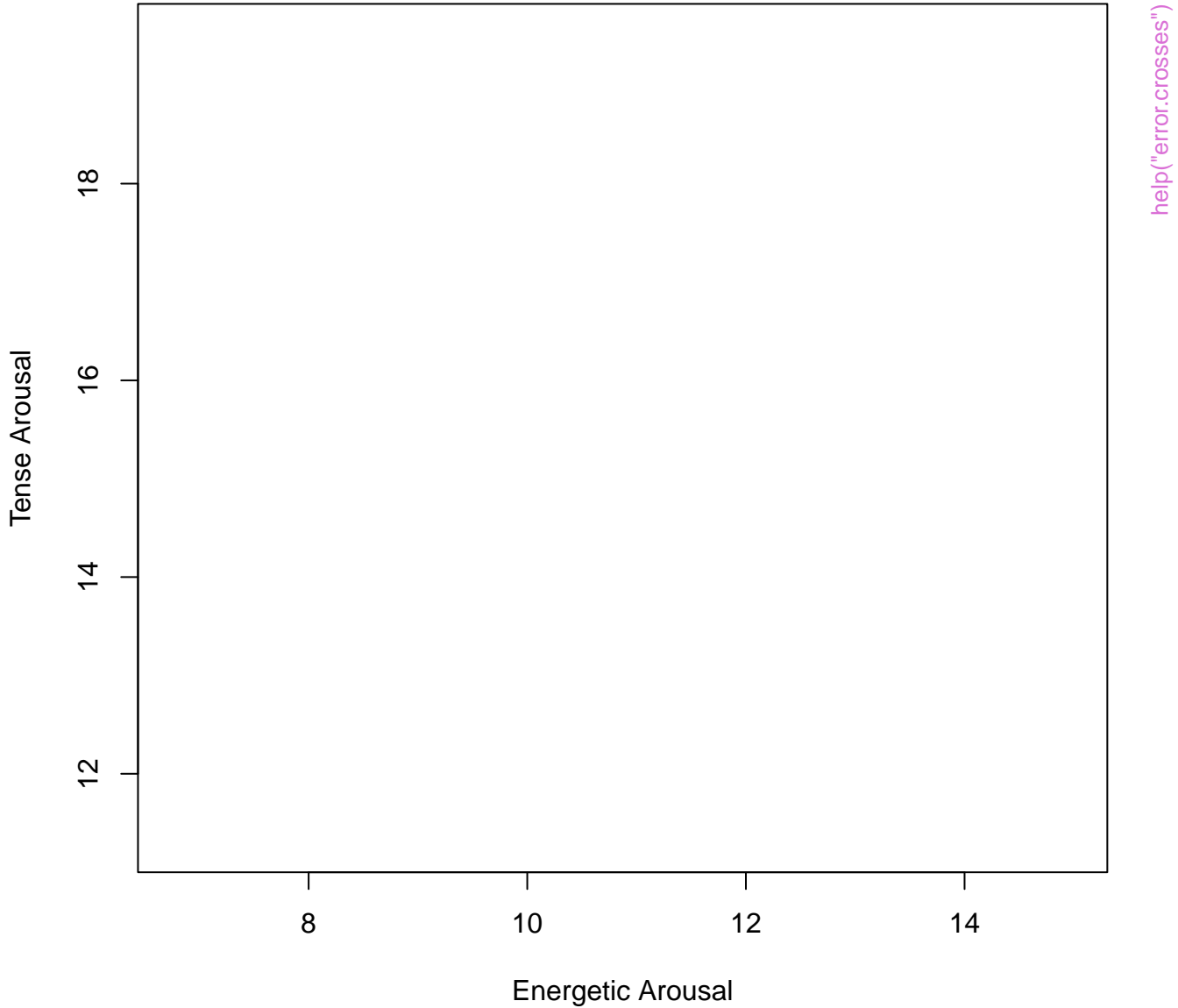

help("error.crosses")

Confidence Intervals around the mean

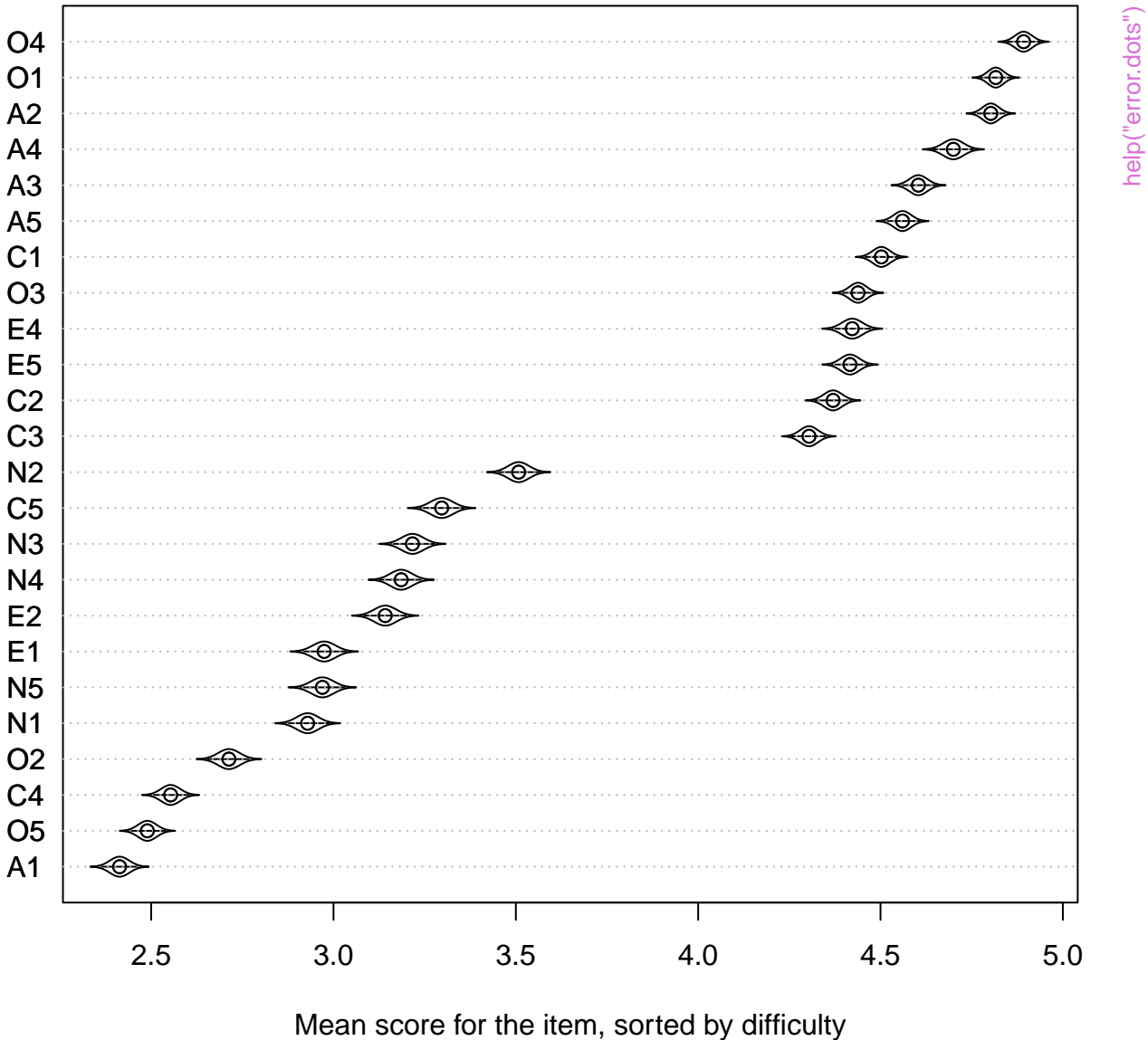

Confidence Intervals around the mean

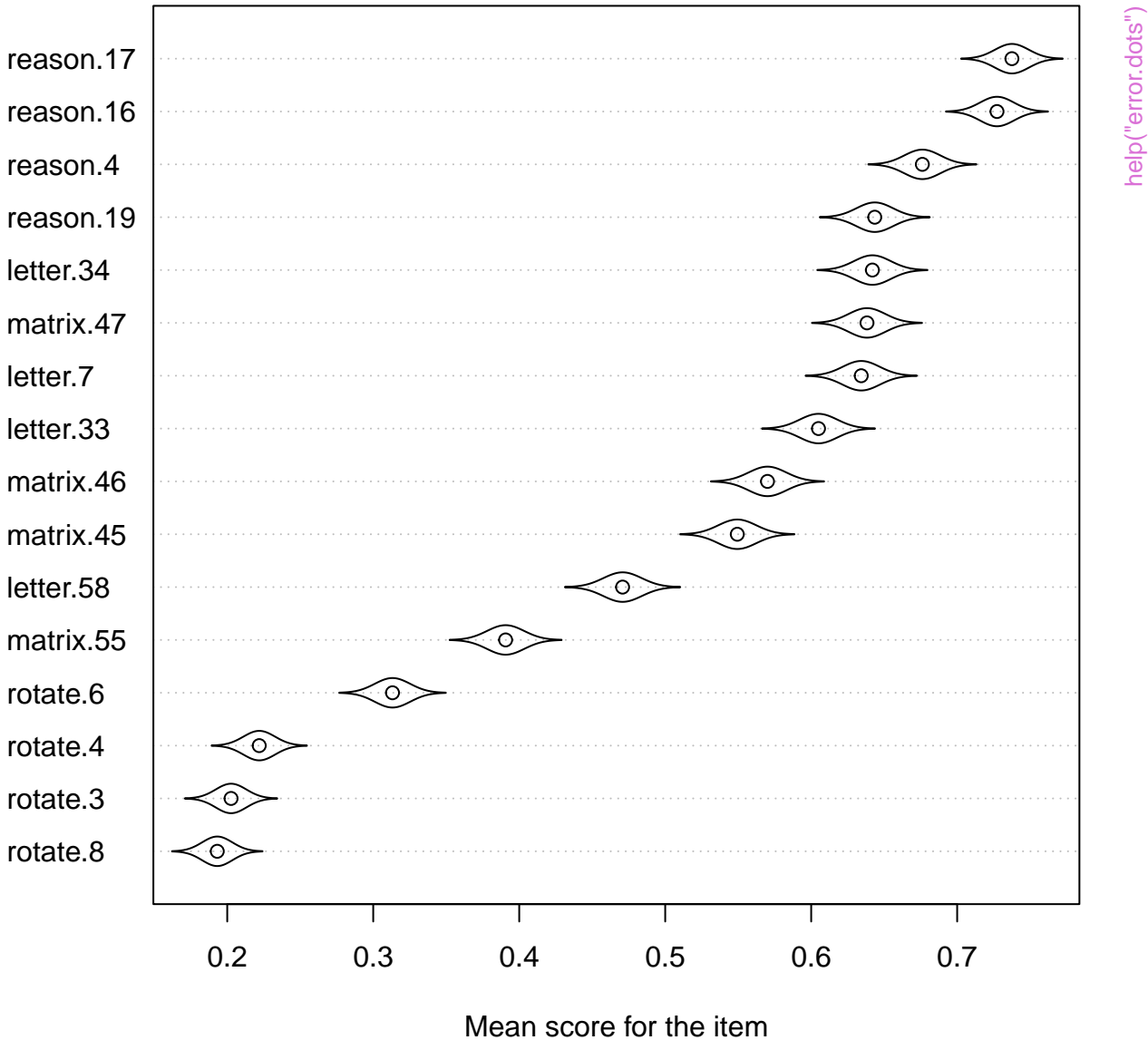

Cohen d and confidence intervals of BFI by gender

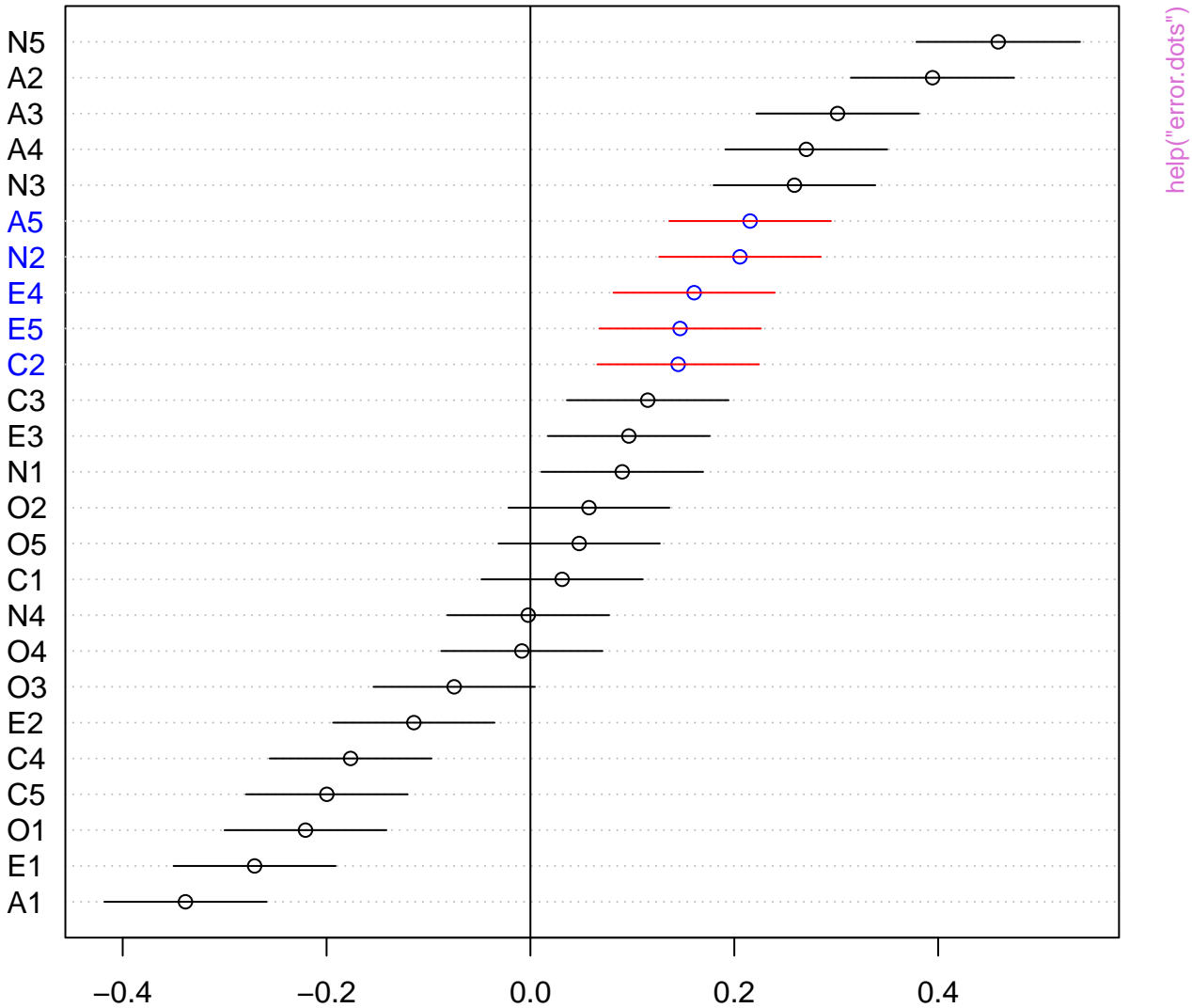

Exploratory Structural Model

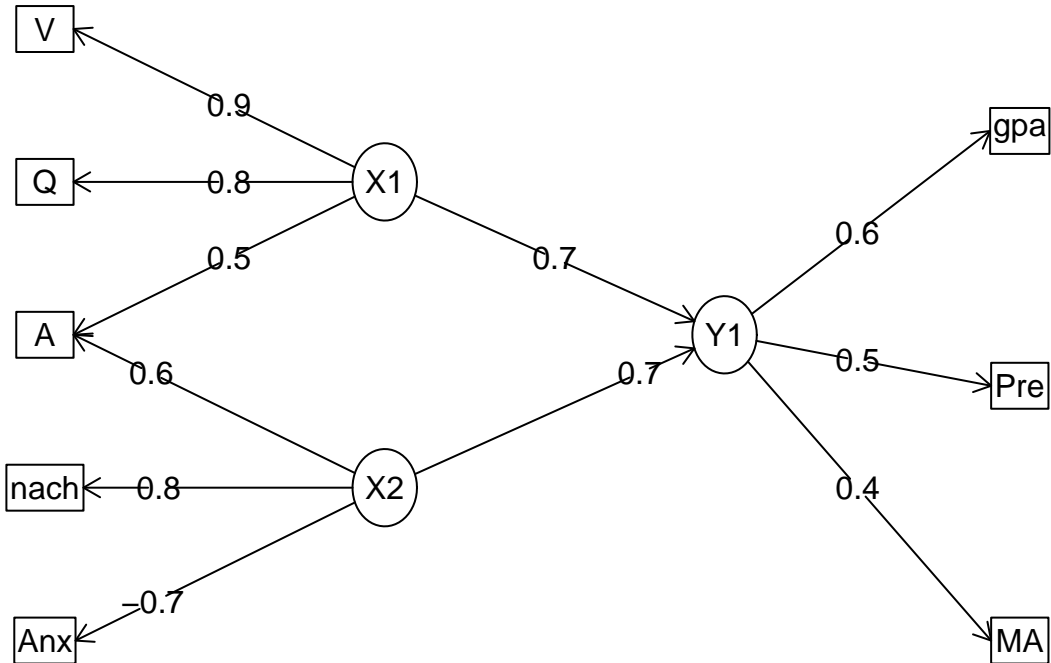

Exploratory Structural Model

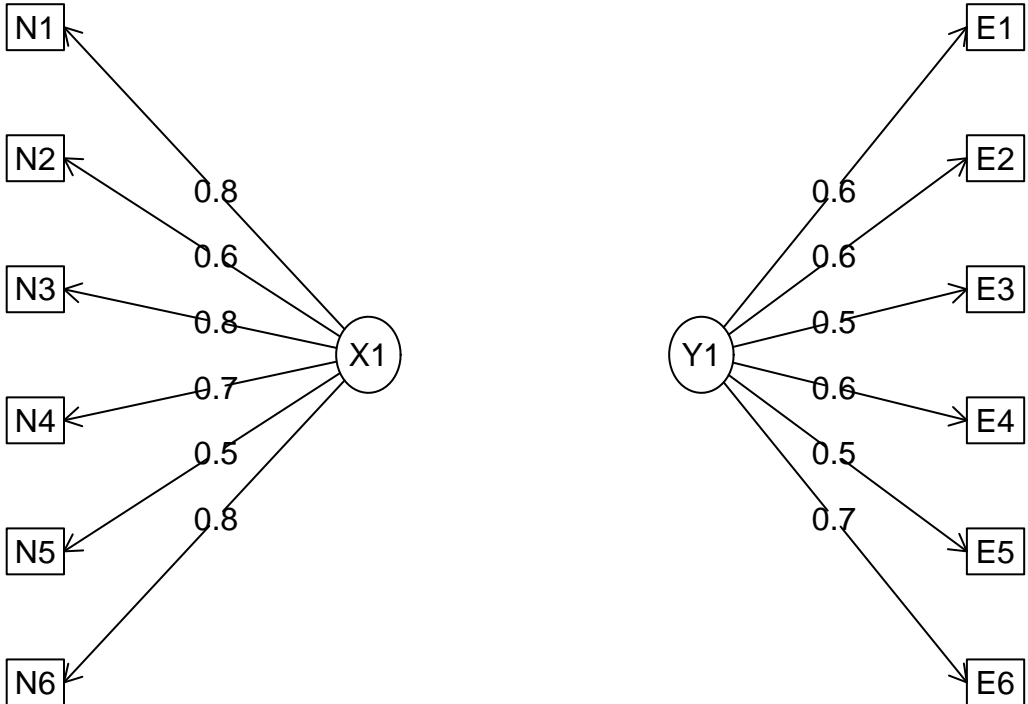

Factor Analysis

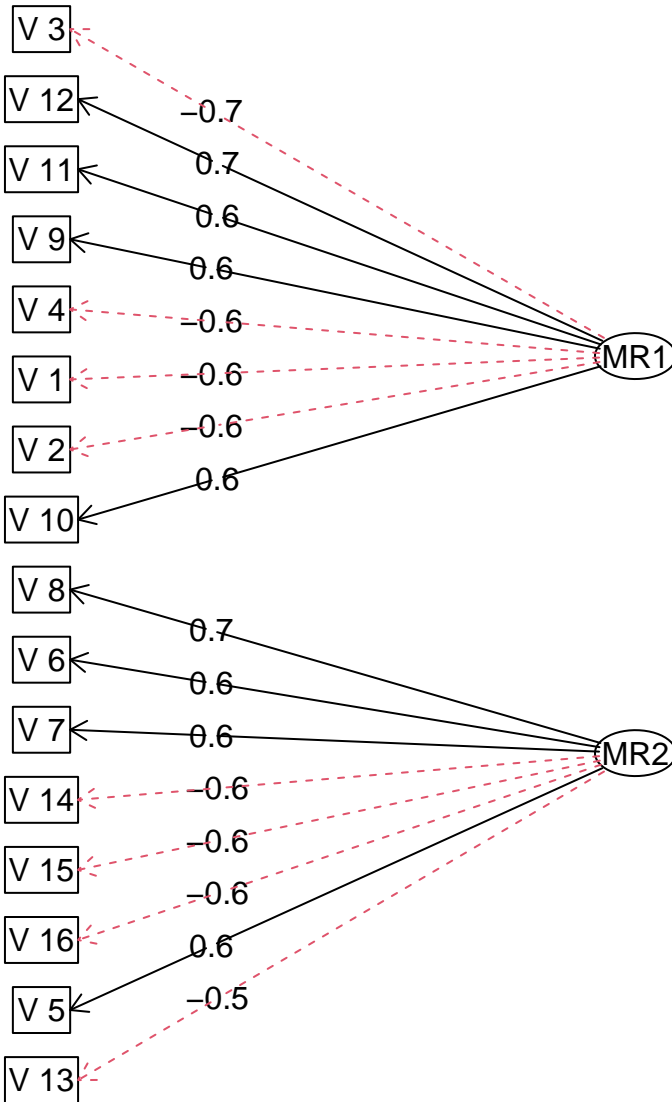

Factor Analysis

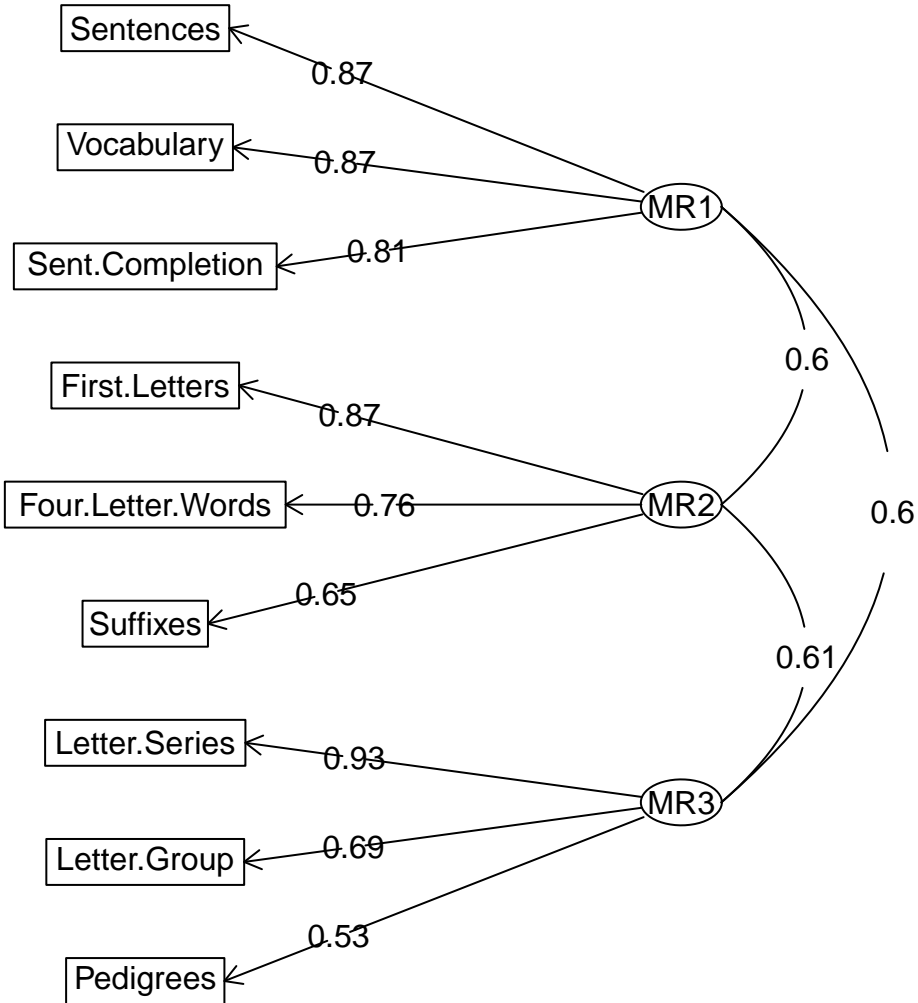

input from a matrix

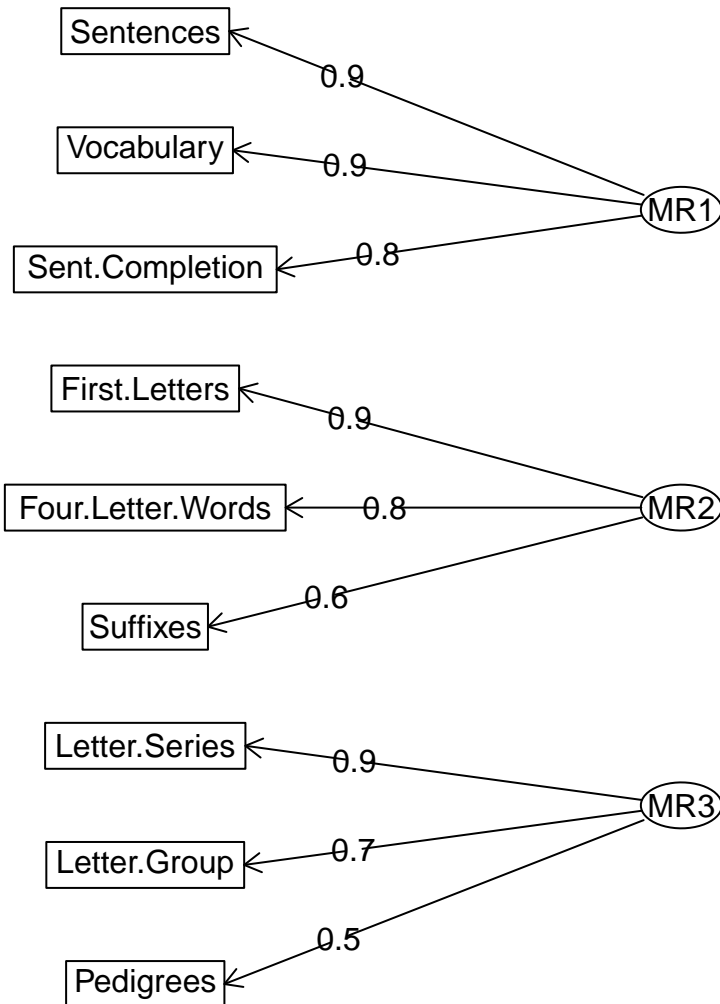

Input from a matrix

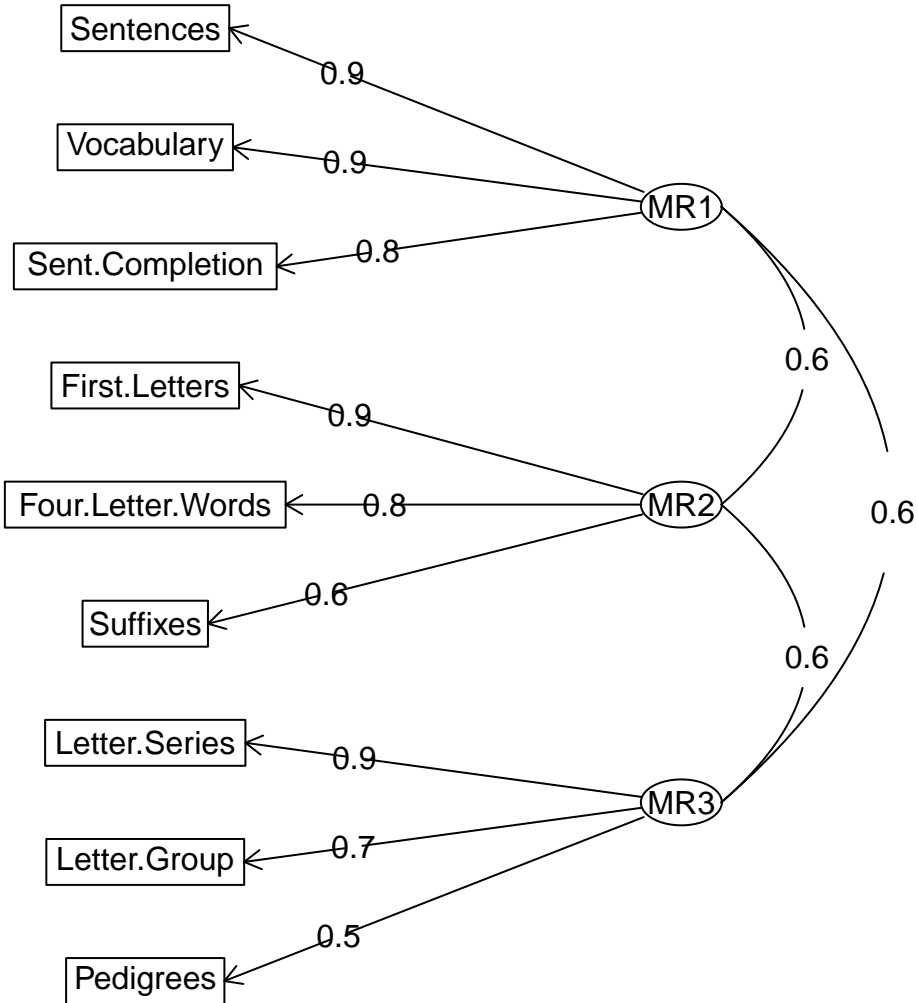

Two cluster solution of Thurstone

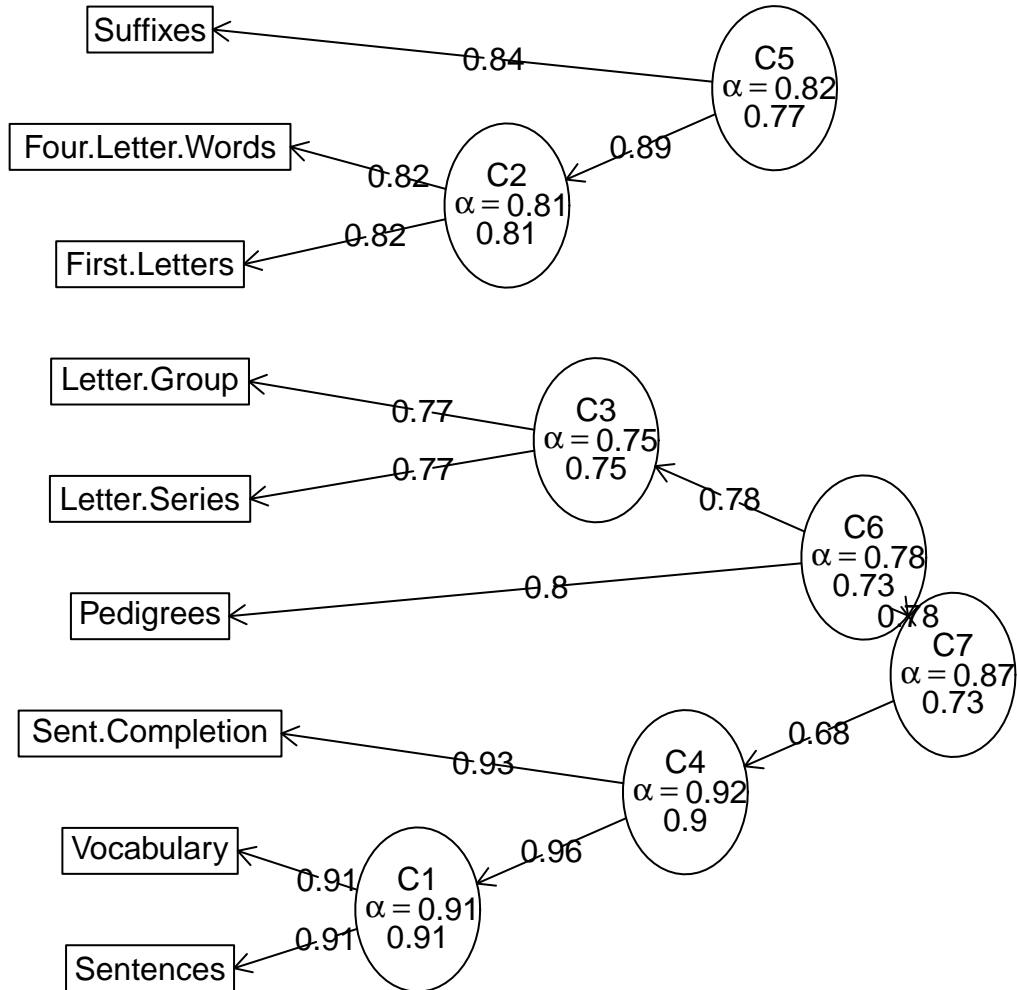

Input from ICLUST

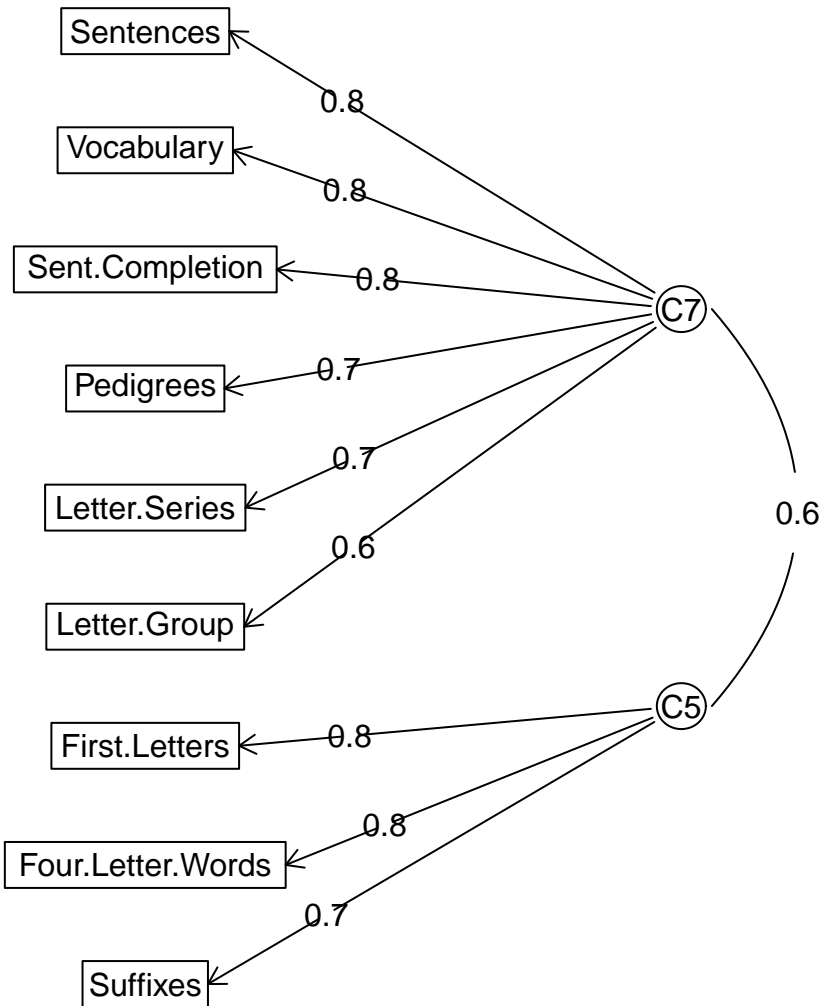

Heterarchy diagram

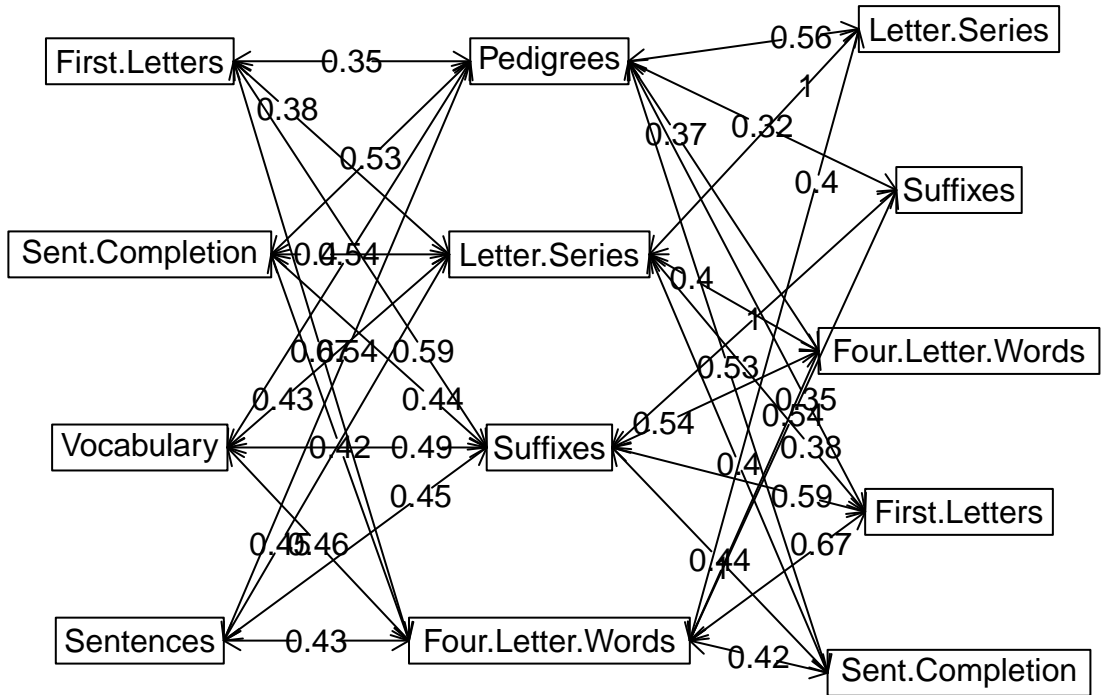

Factor analysis and extension

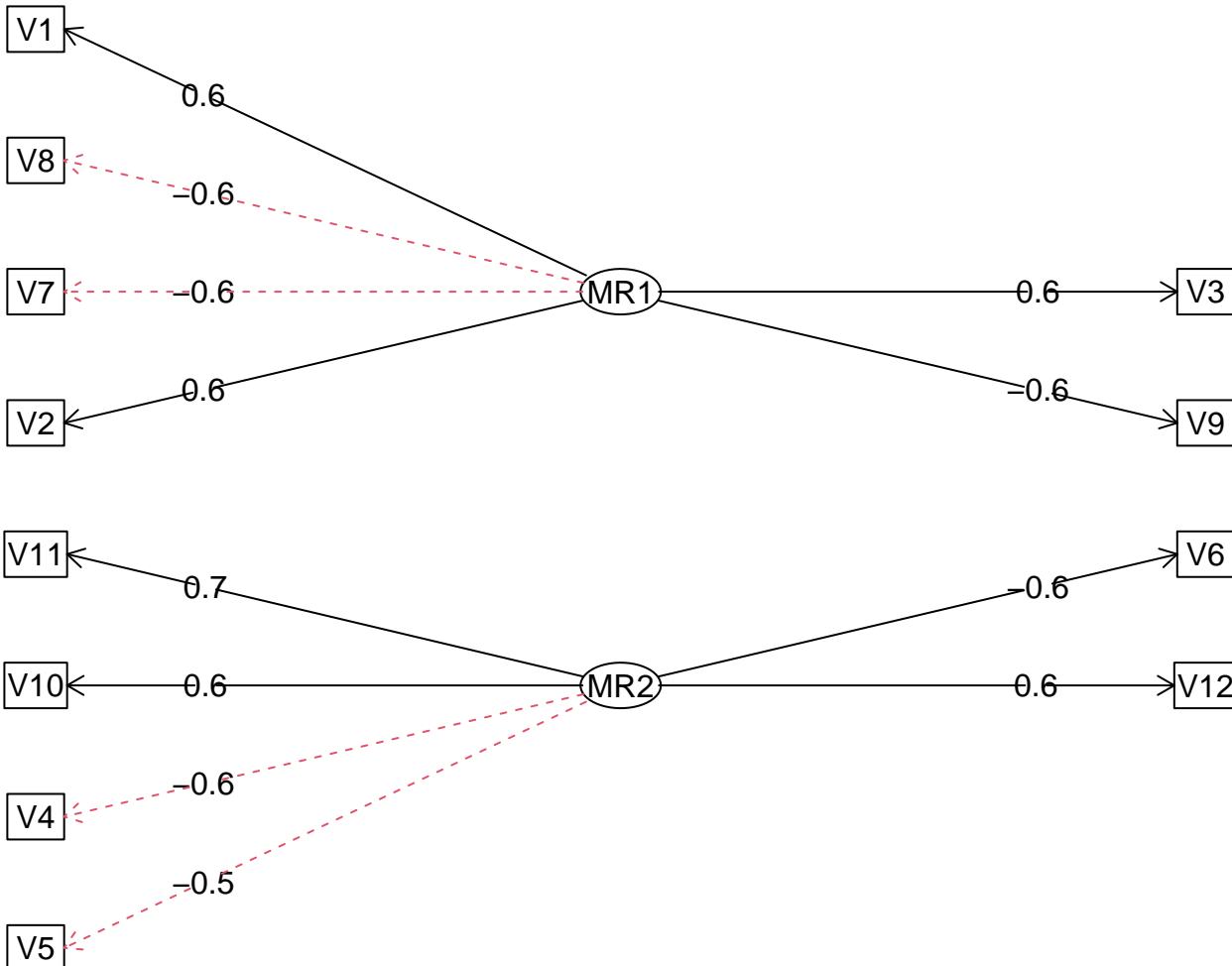

Factor analysis and extension

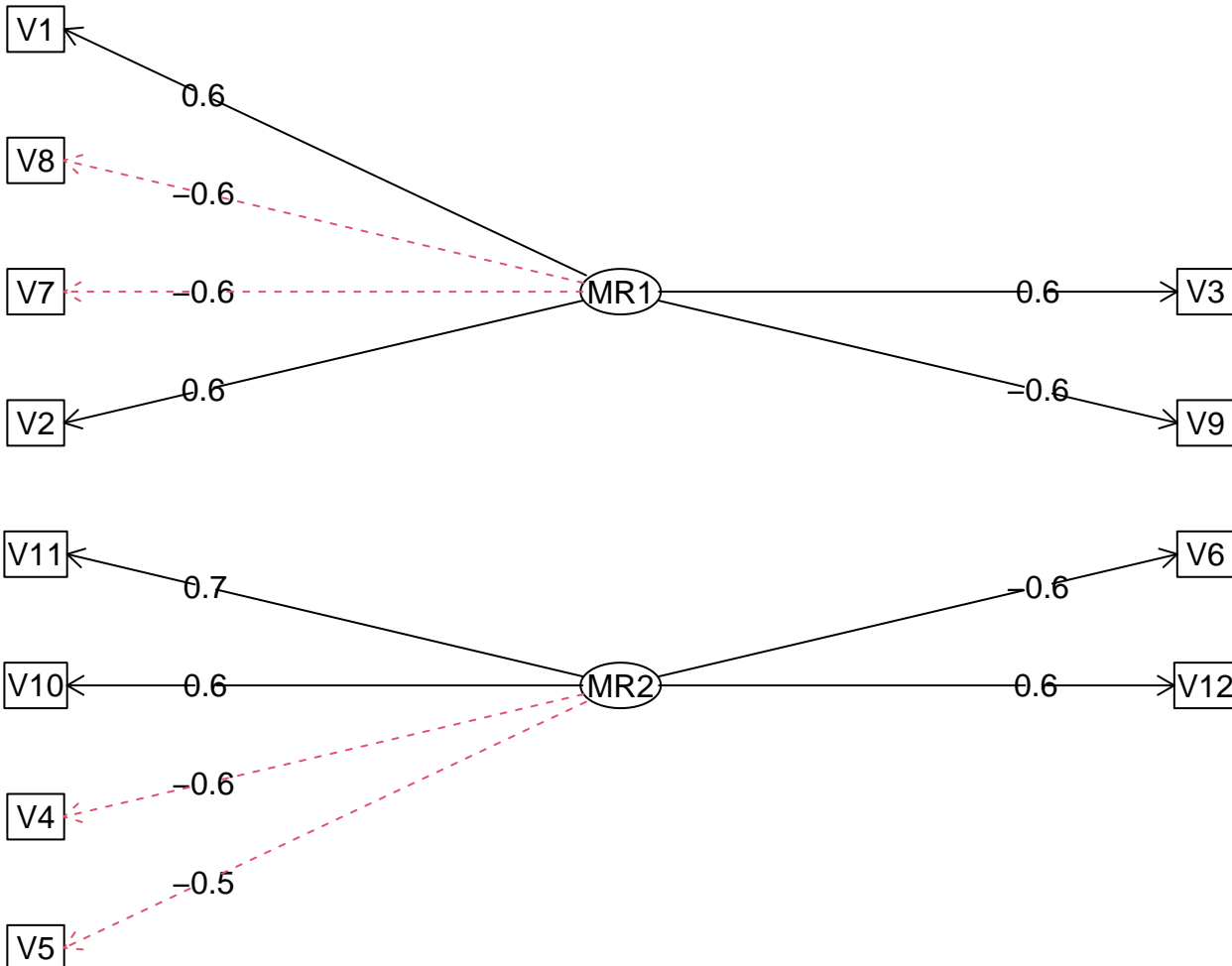

Factor analysis and extension

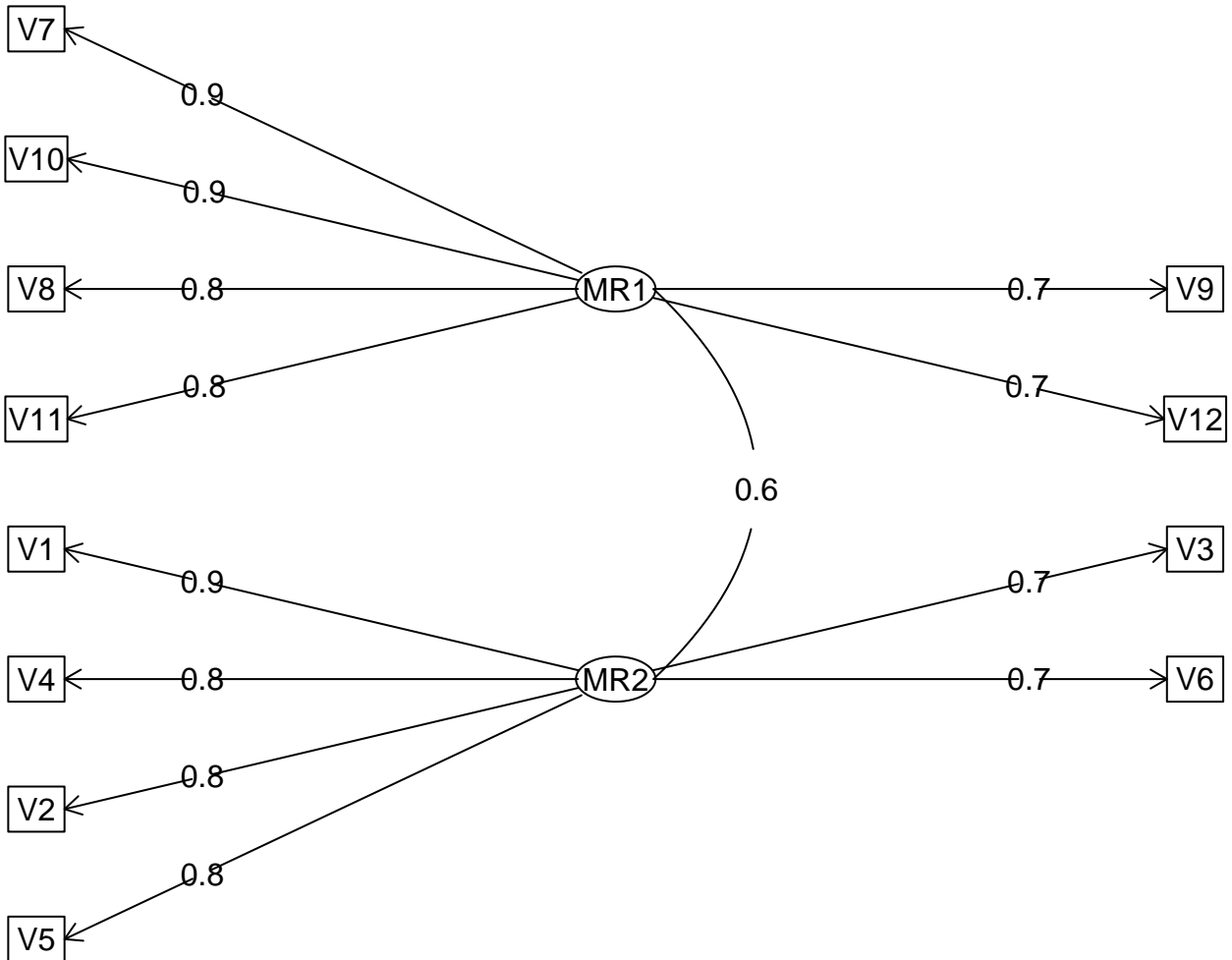

factor analysis with extension variables

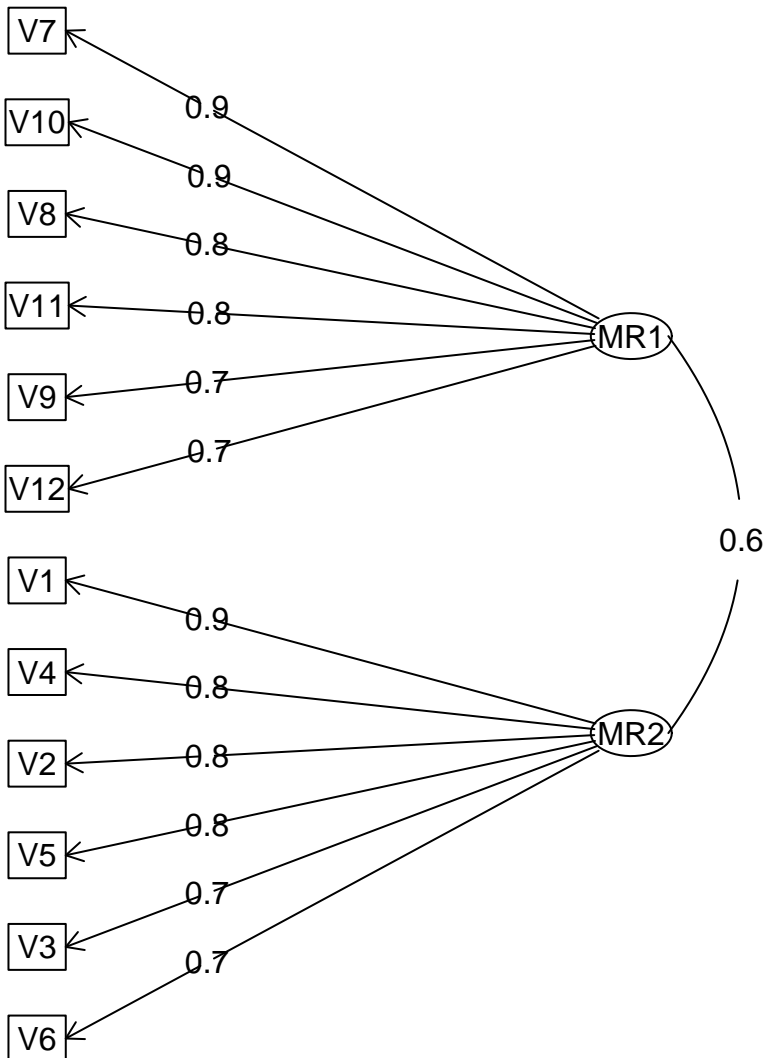

Omega

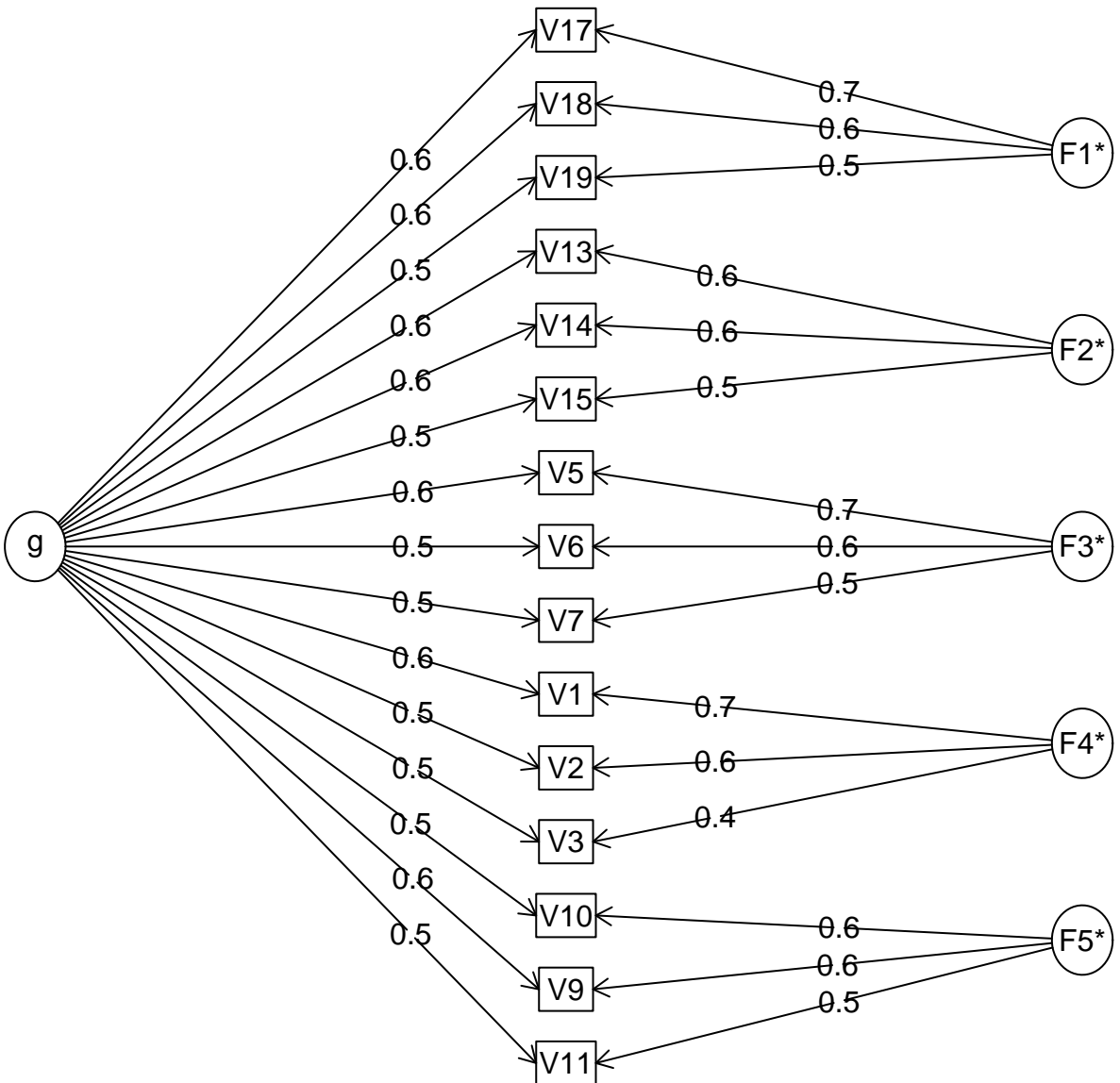

Extended Omega

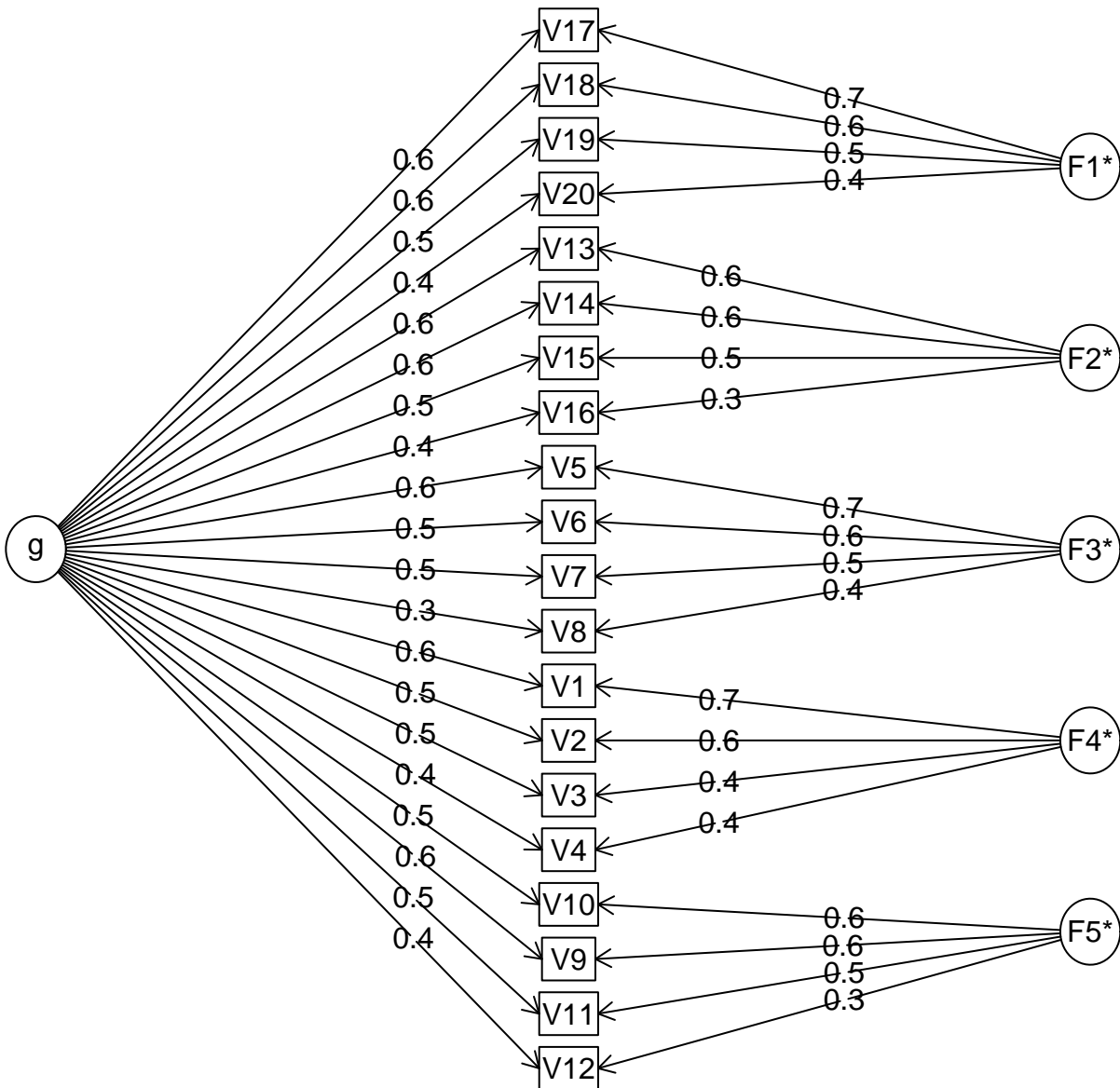

Parallel Analysis Scree Plots

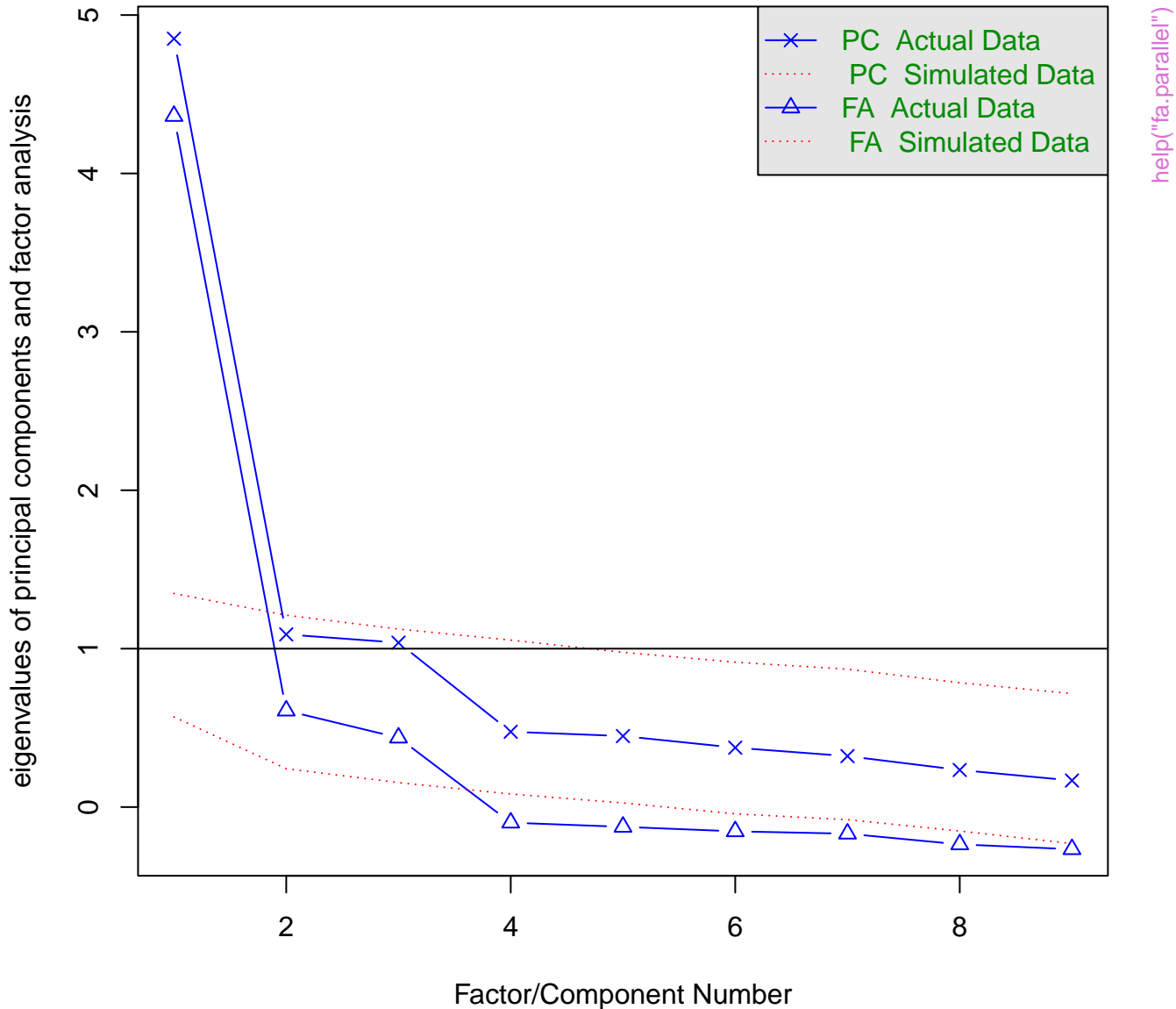

Hierarchical (multilevel) Structure

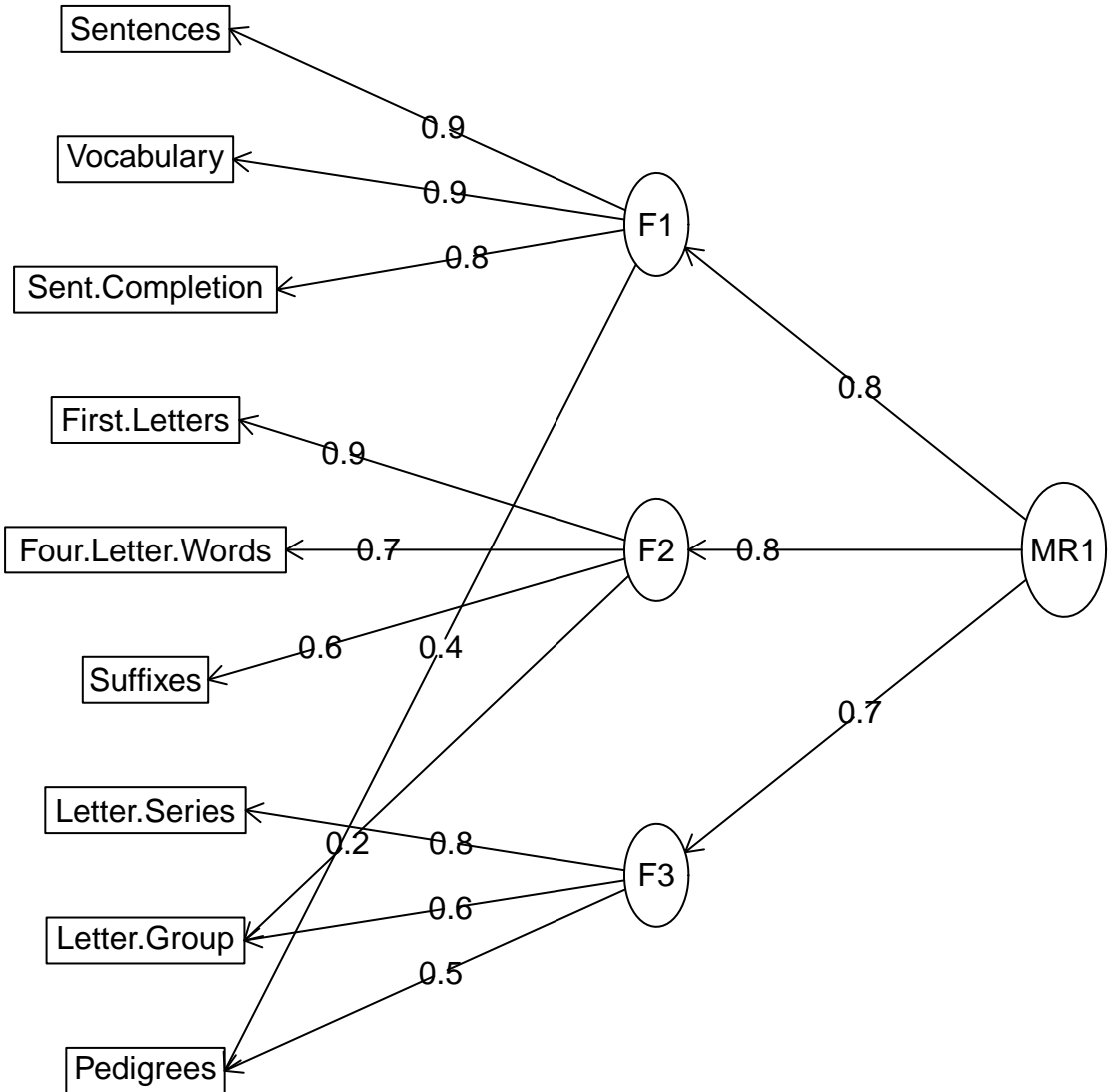

Unrotated

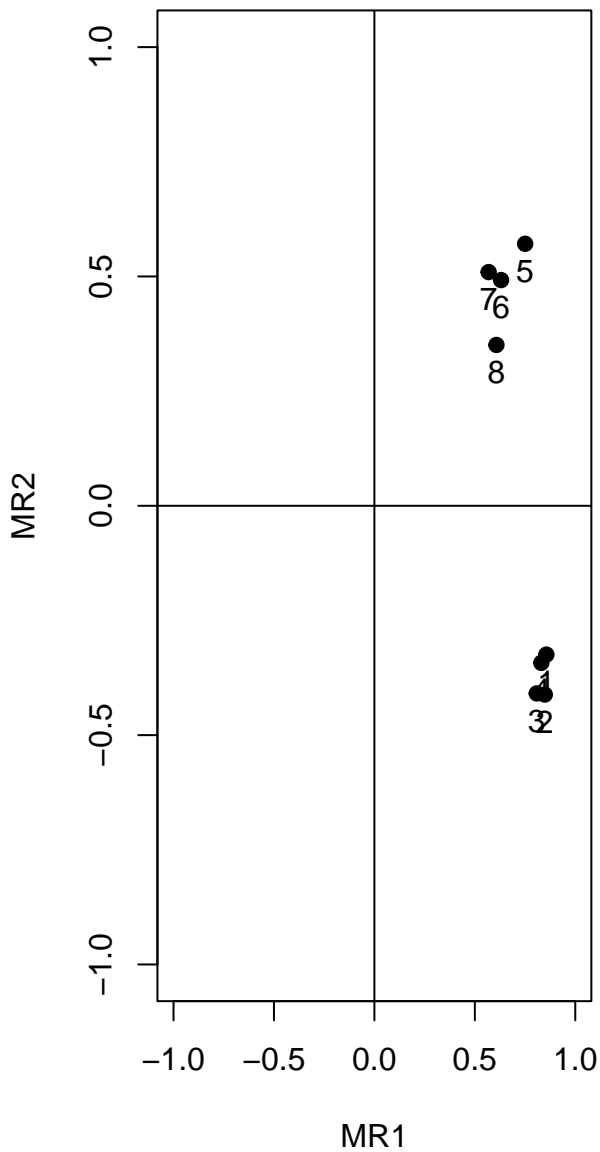

rotated -33 degrees

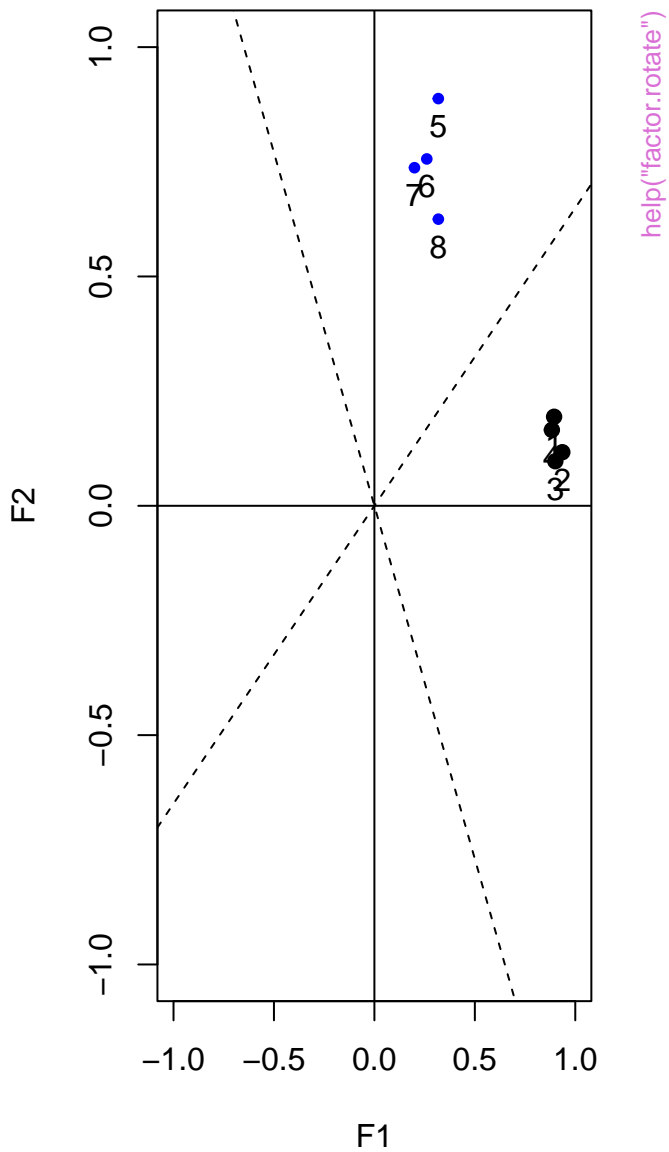

help("factor.rotate")

ICLUST

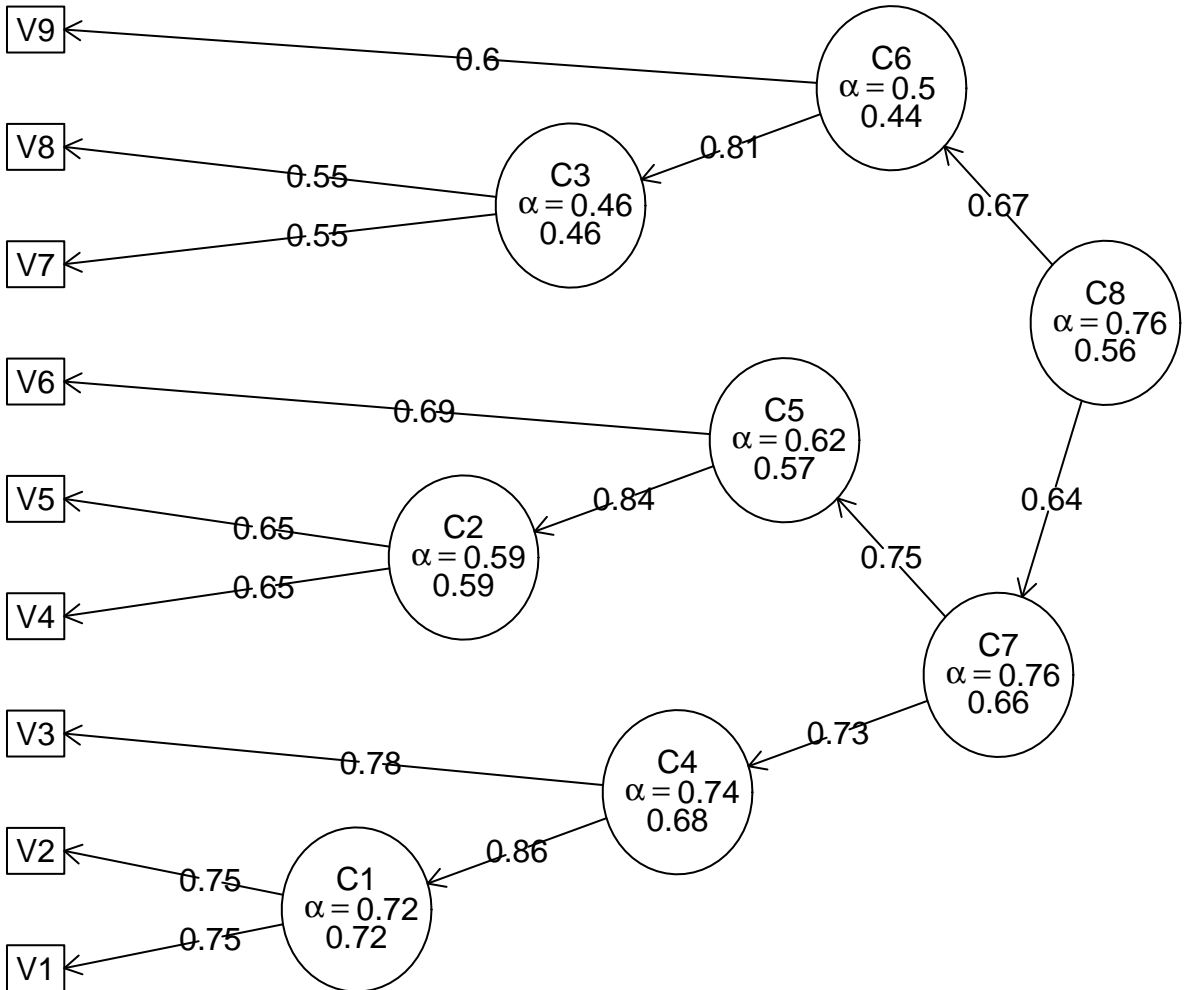

ICLUST

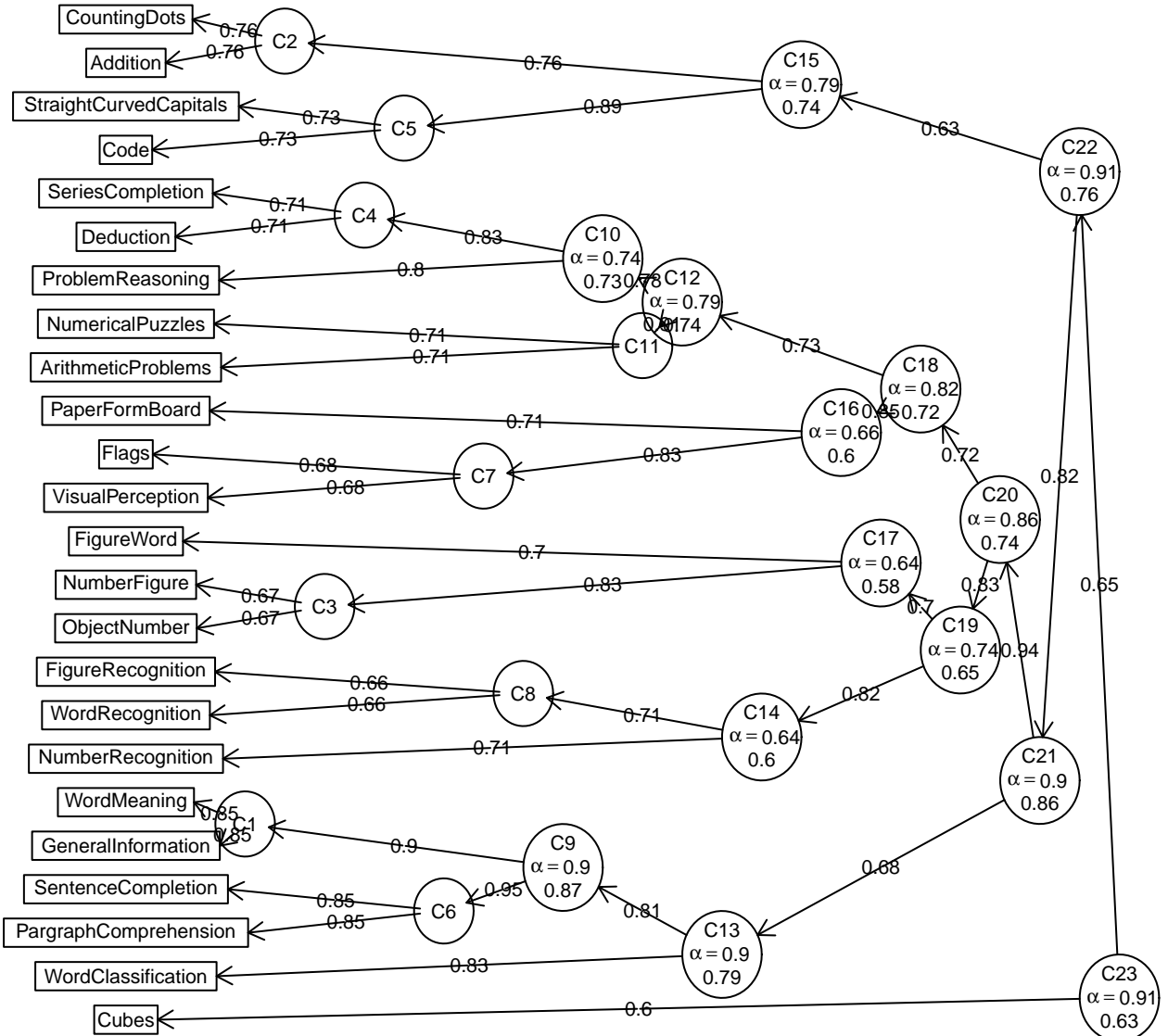

ICLUST

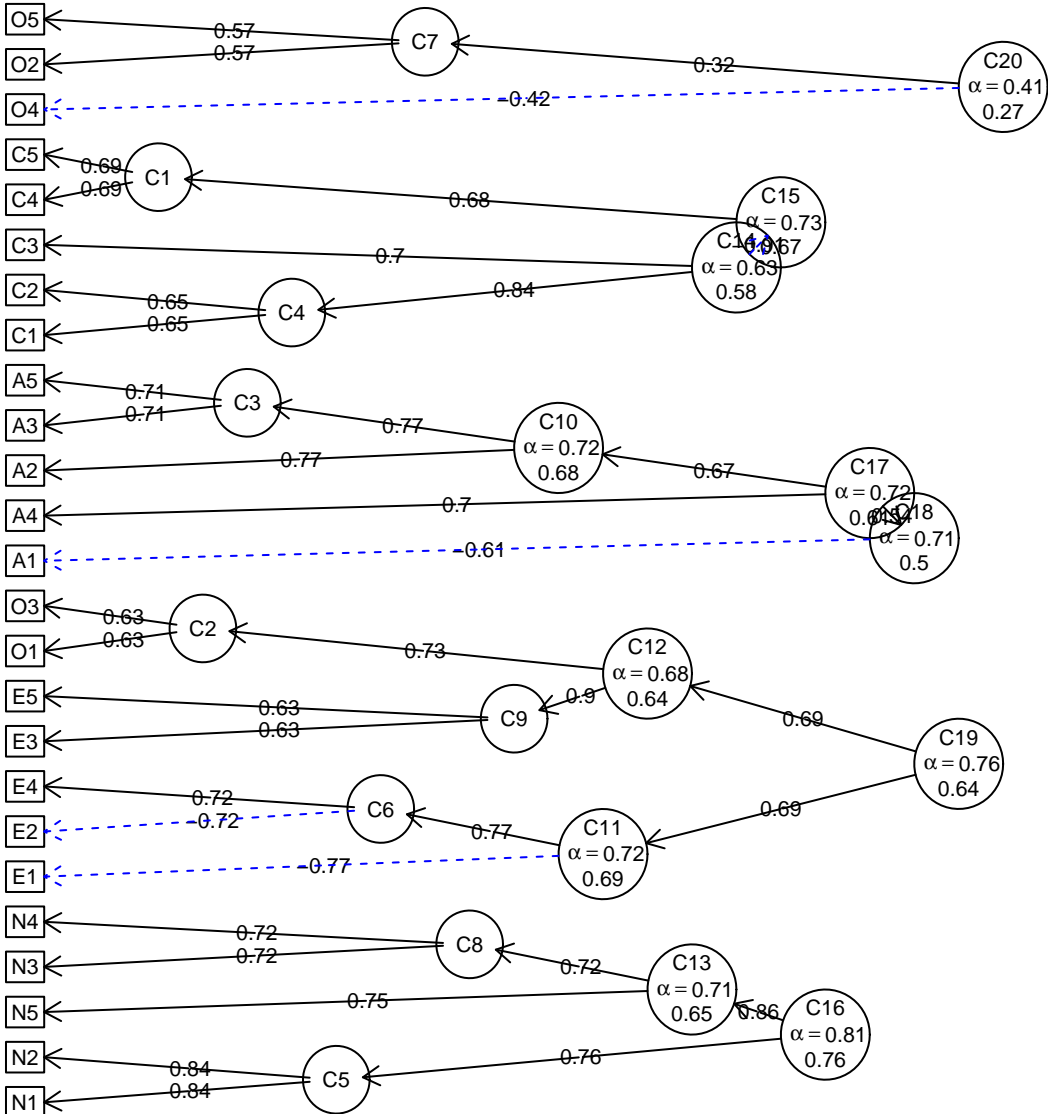

ICLUST diagram

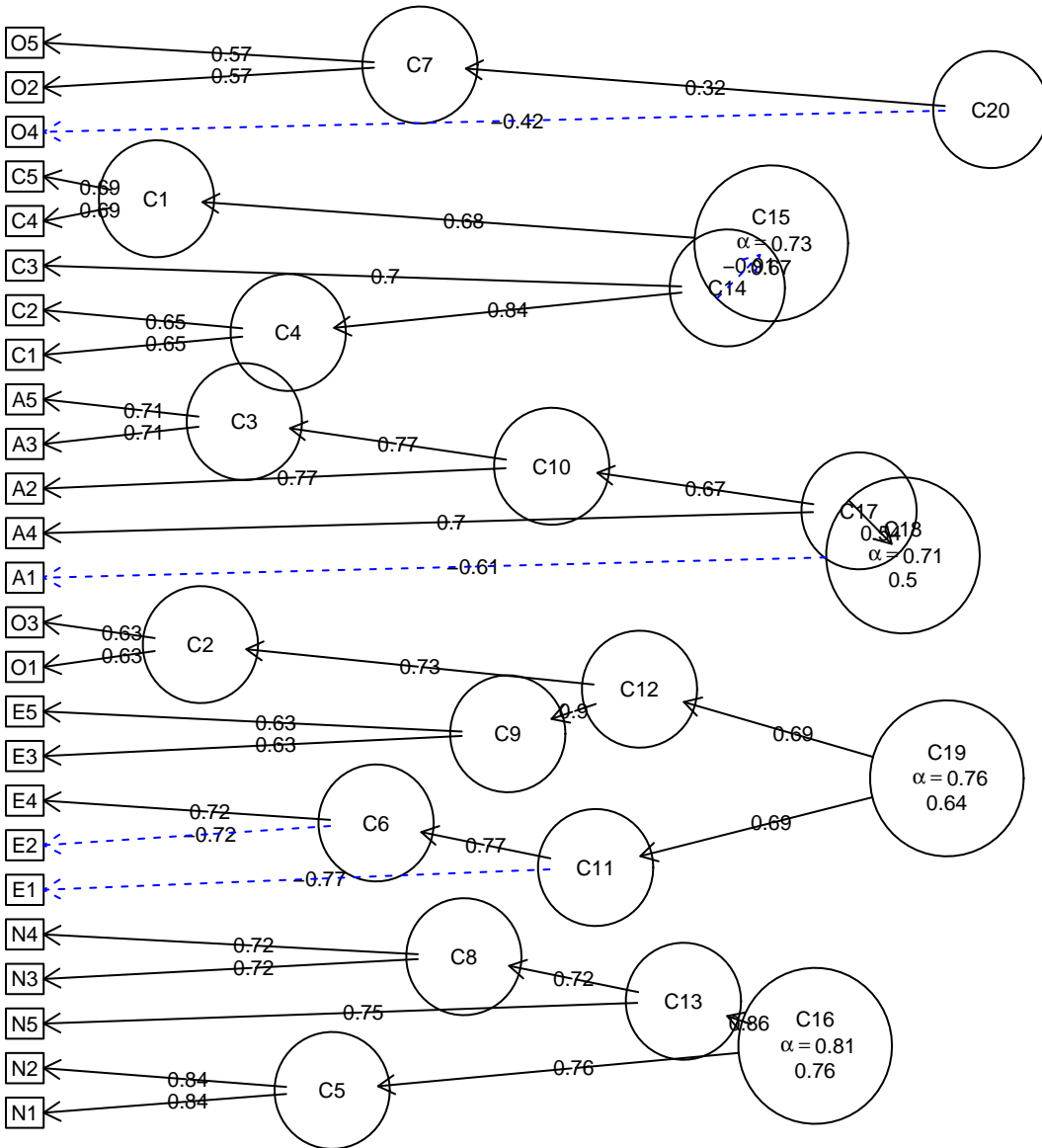

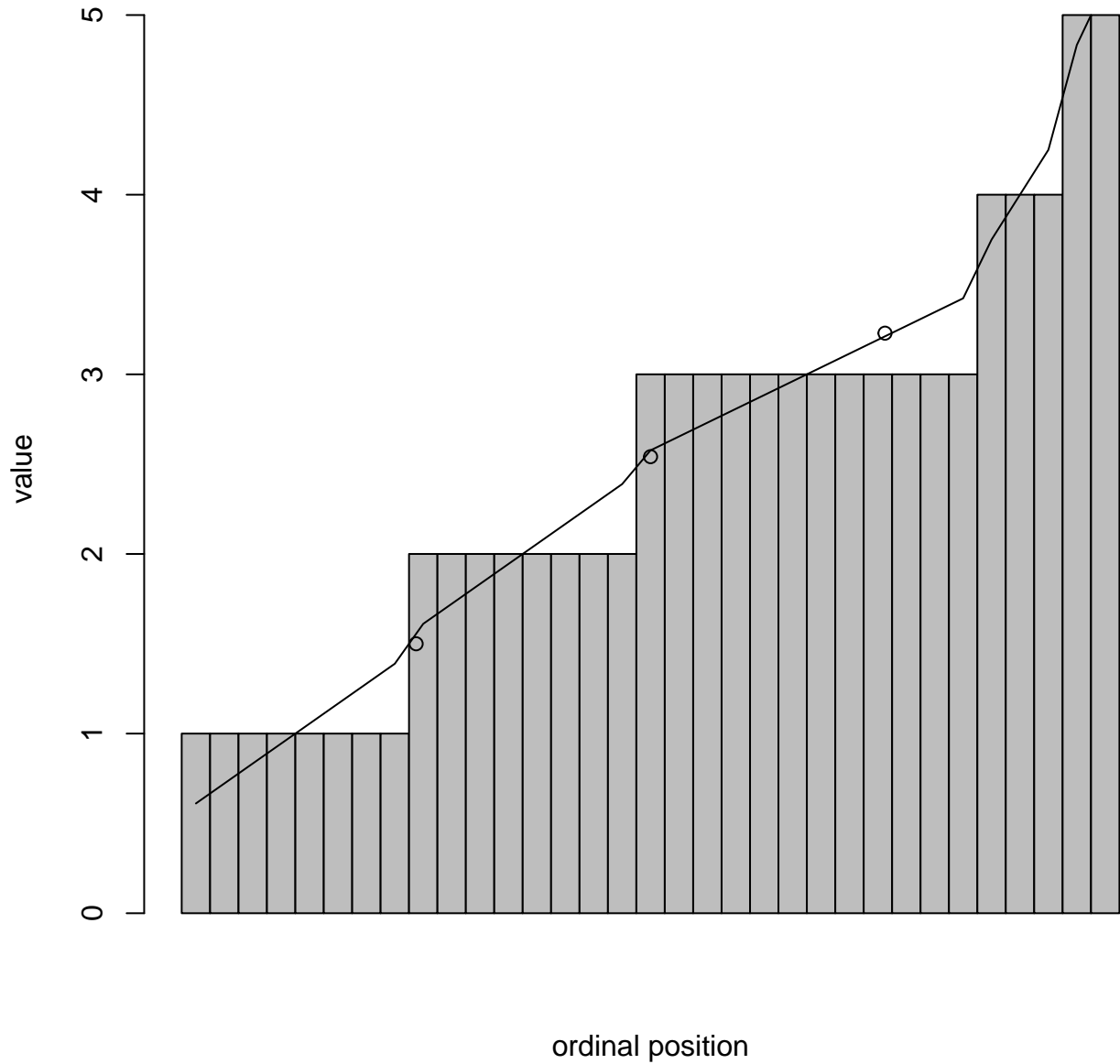

help("interp.median")

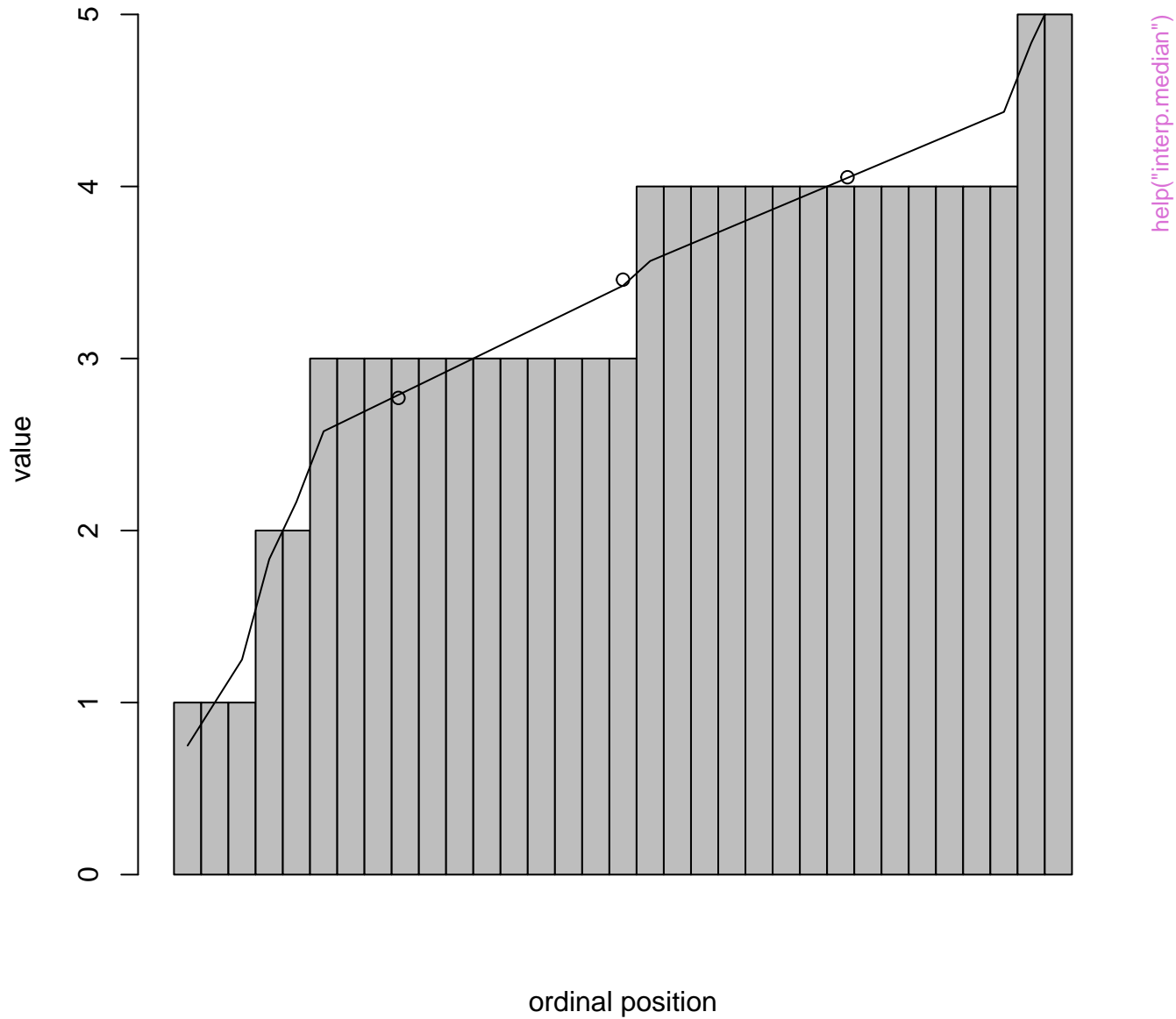

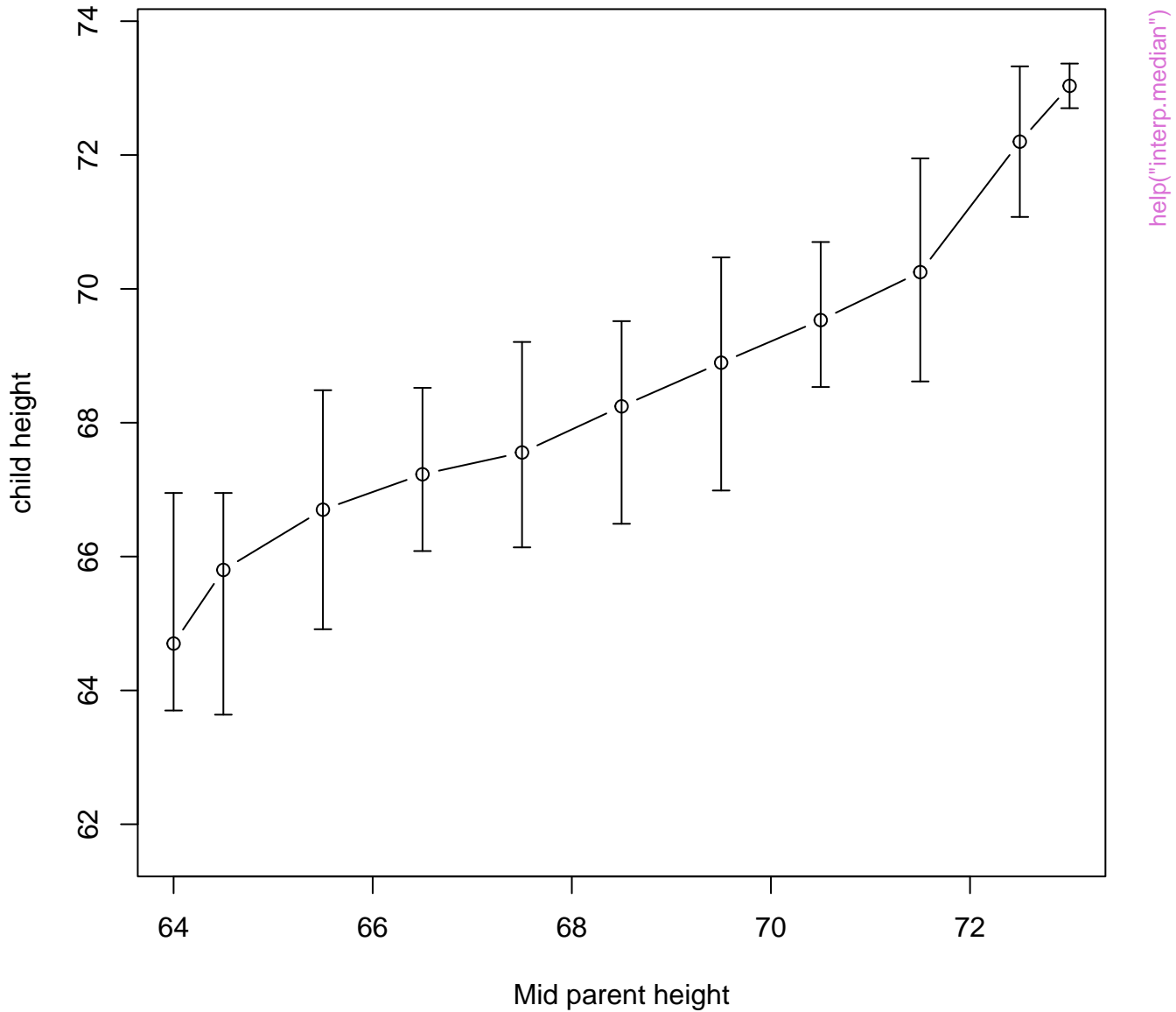

Item information from factor analysis

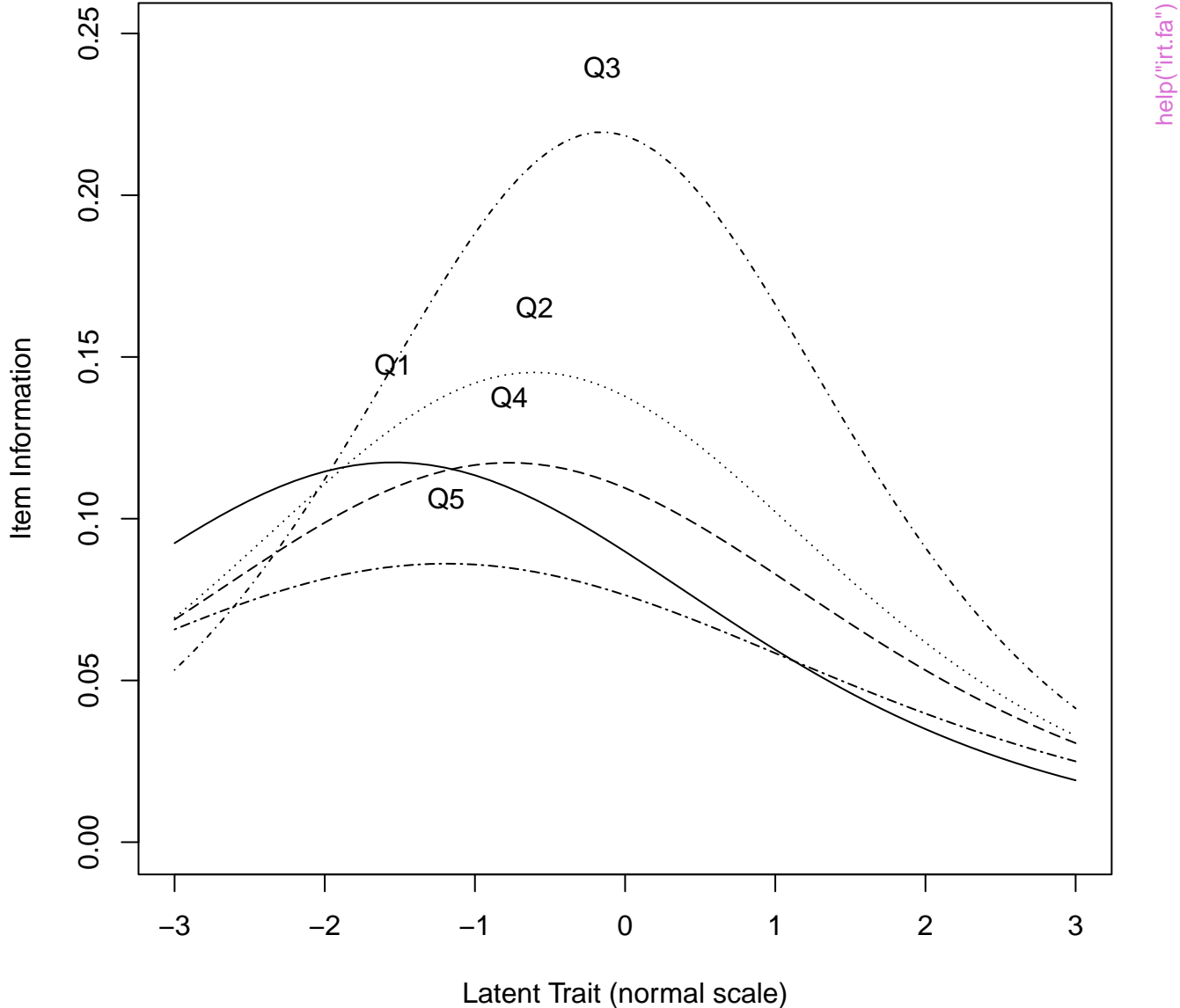

help("irt.fa")

reason.4

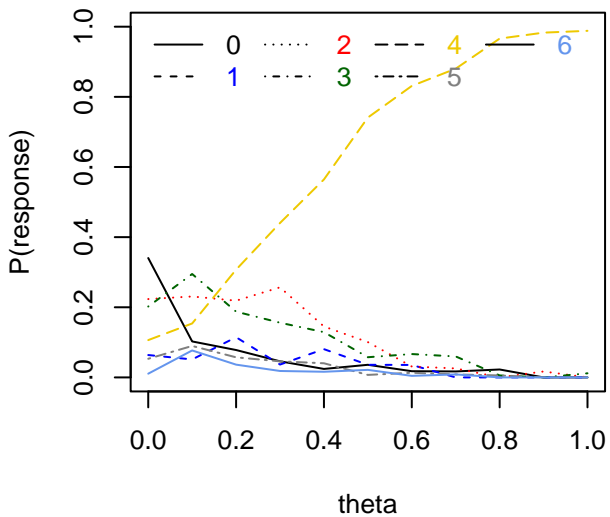

reason.16

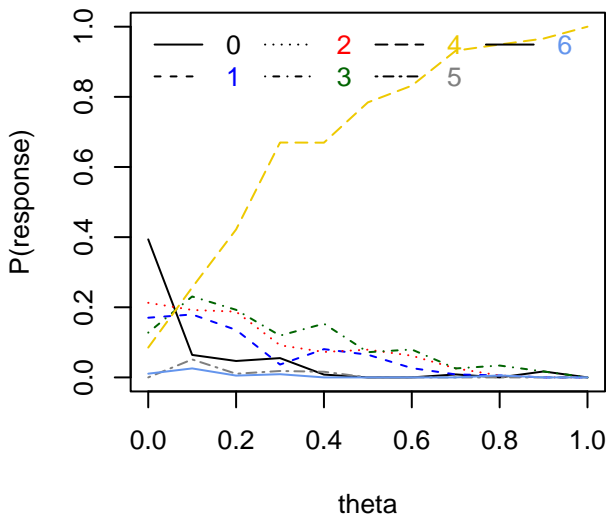

reason.17

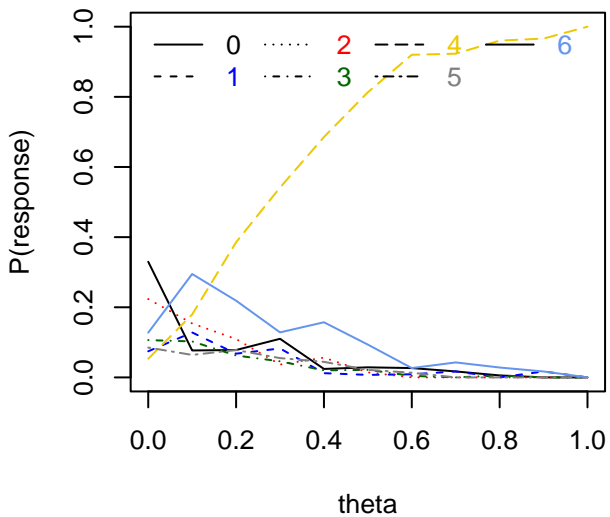

reason.19

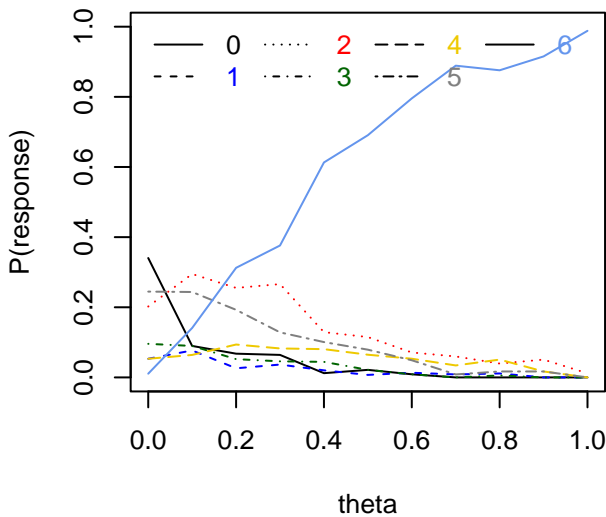

help("irt.responses")

Logistic transform of x

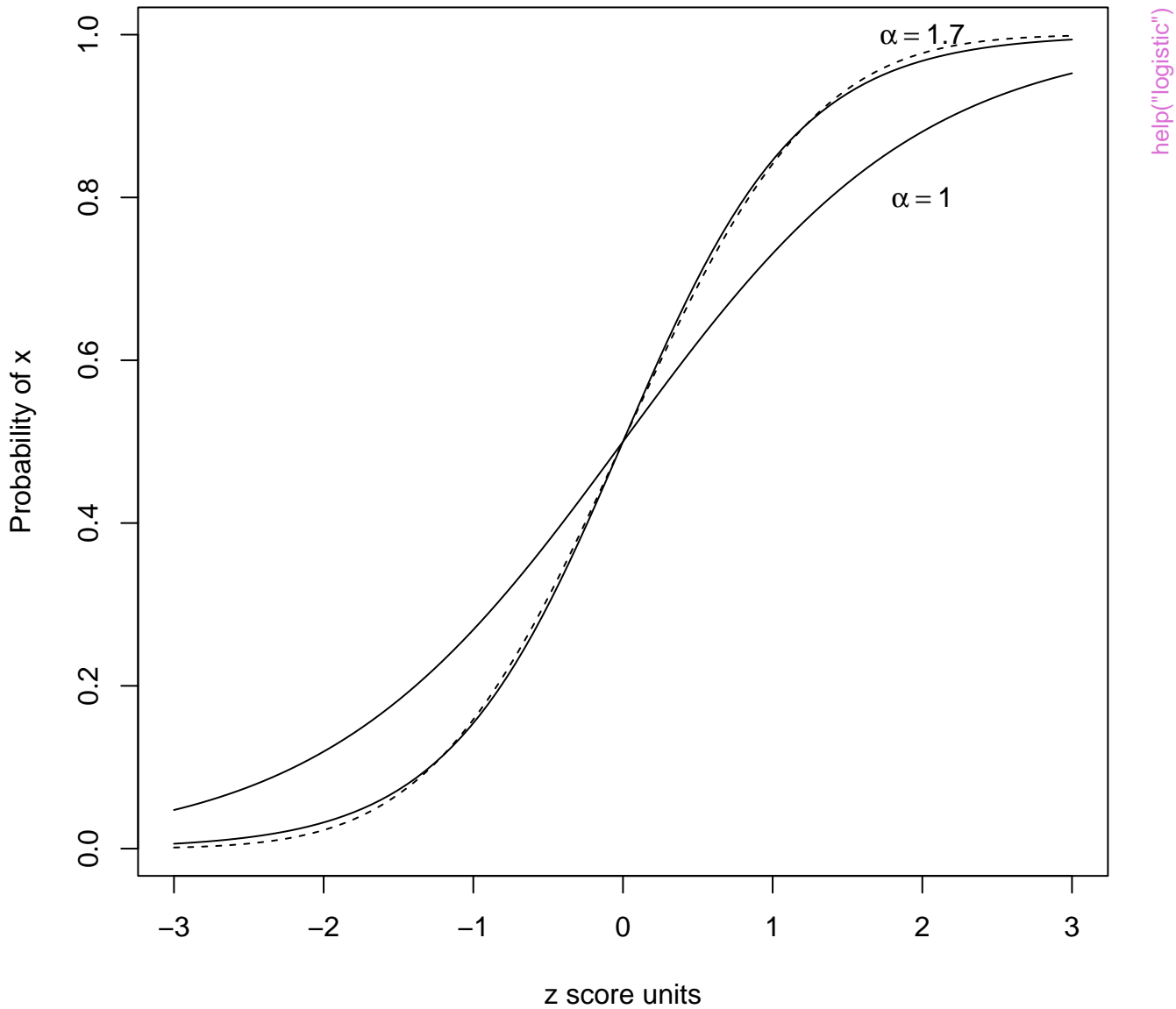

help("logistic")

Logistic transform of x in logit units

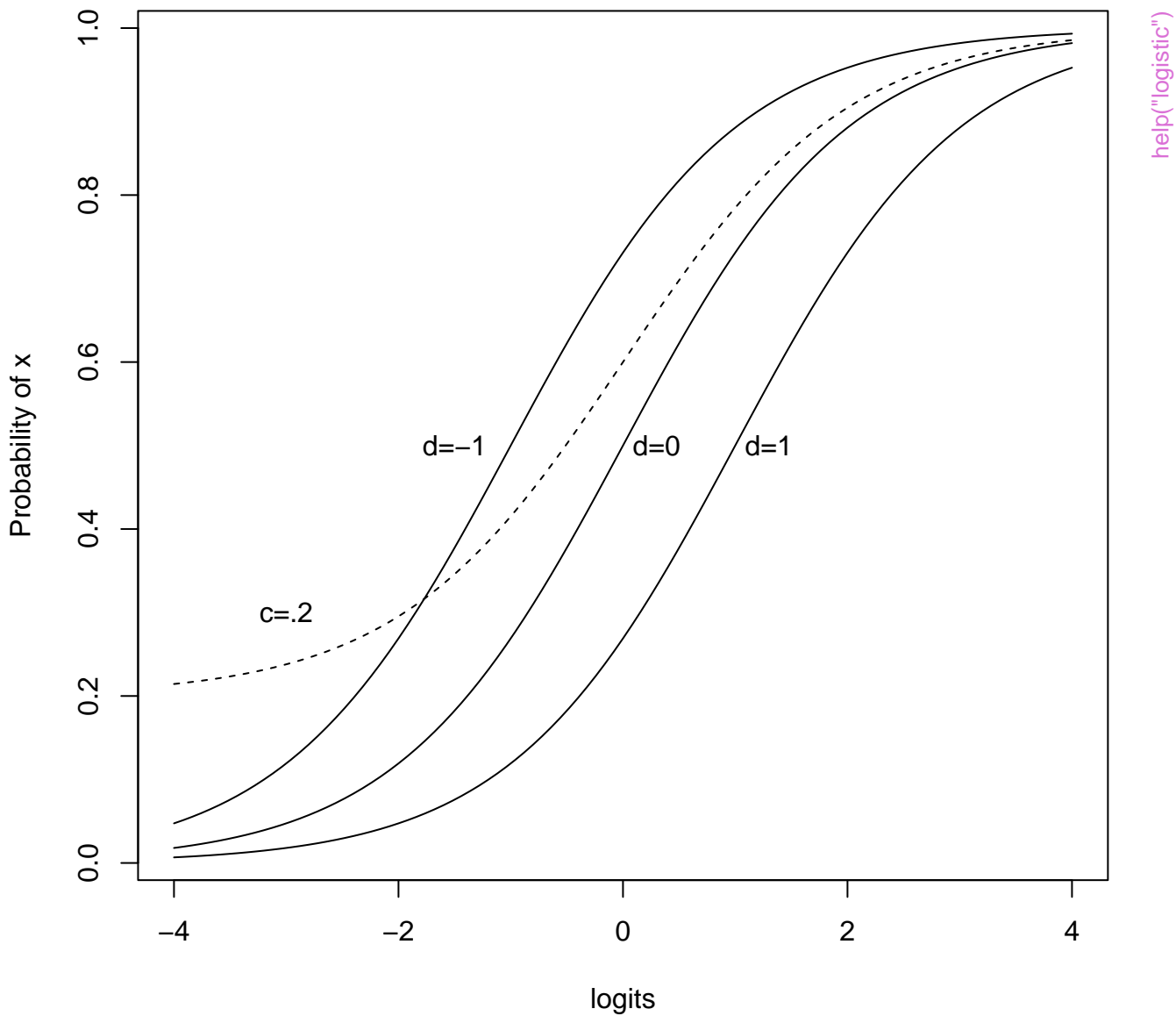

Five level response scale

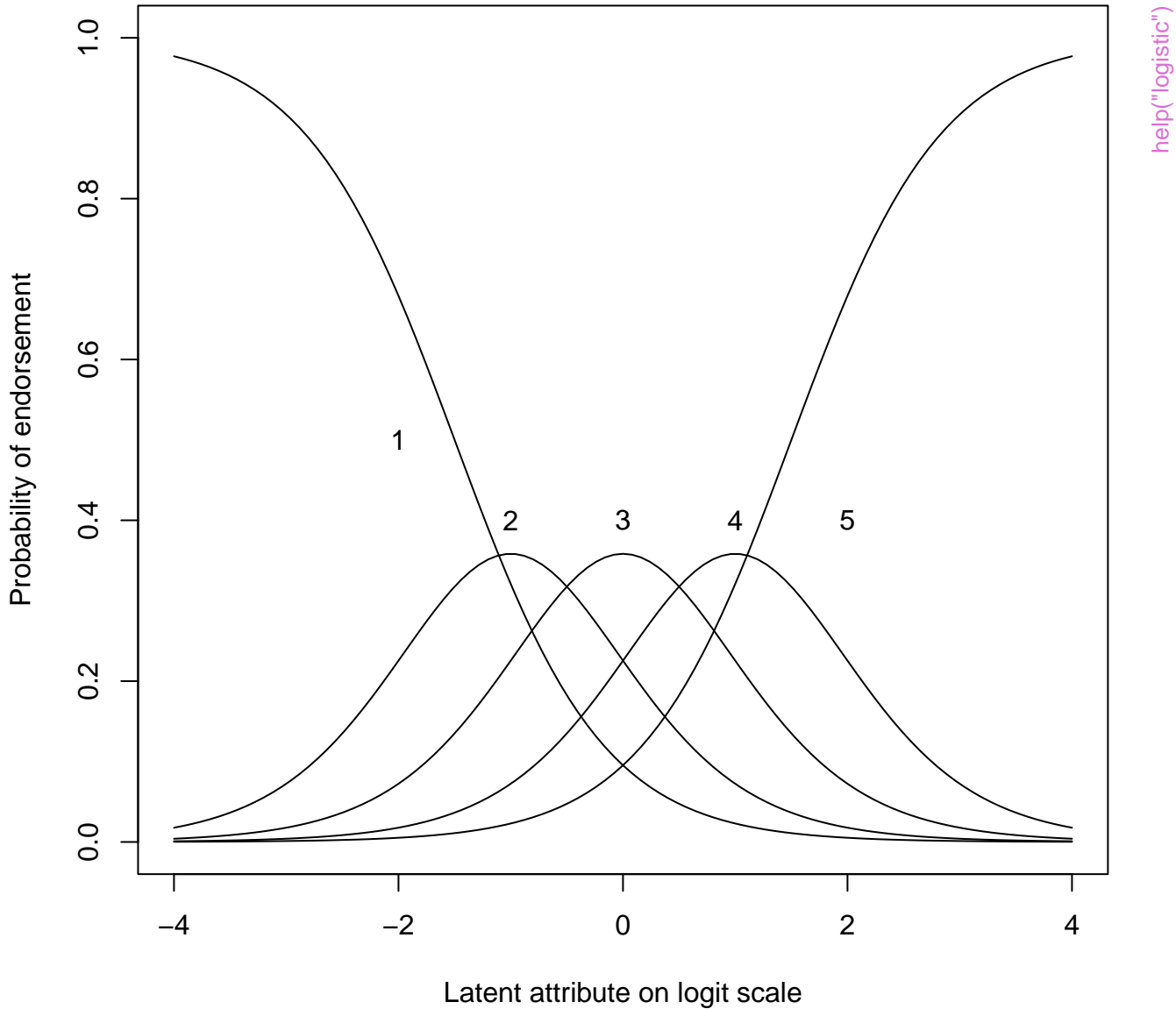

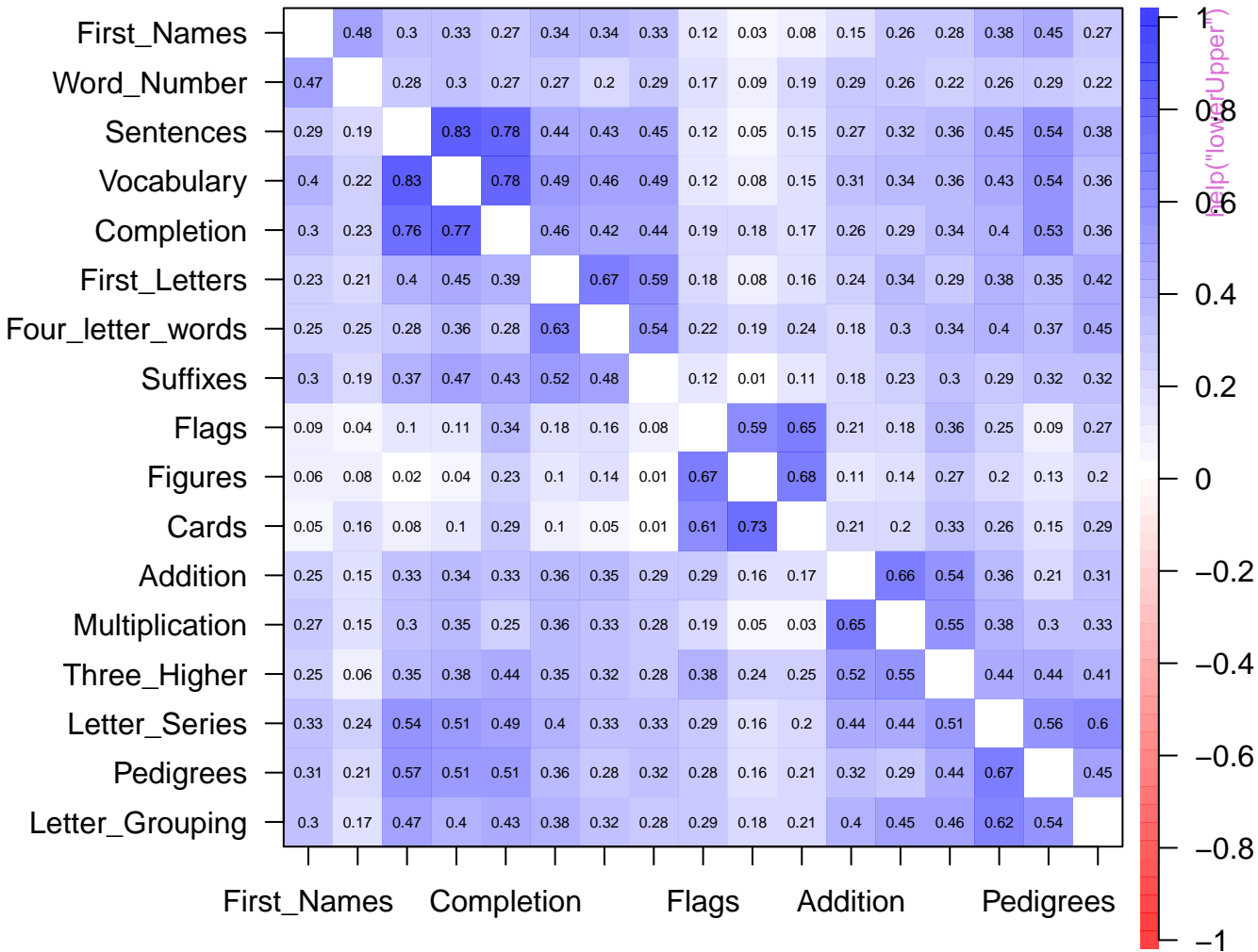

Bechtoldt1 and the differences from Bechtoldt2

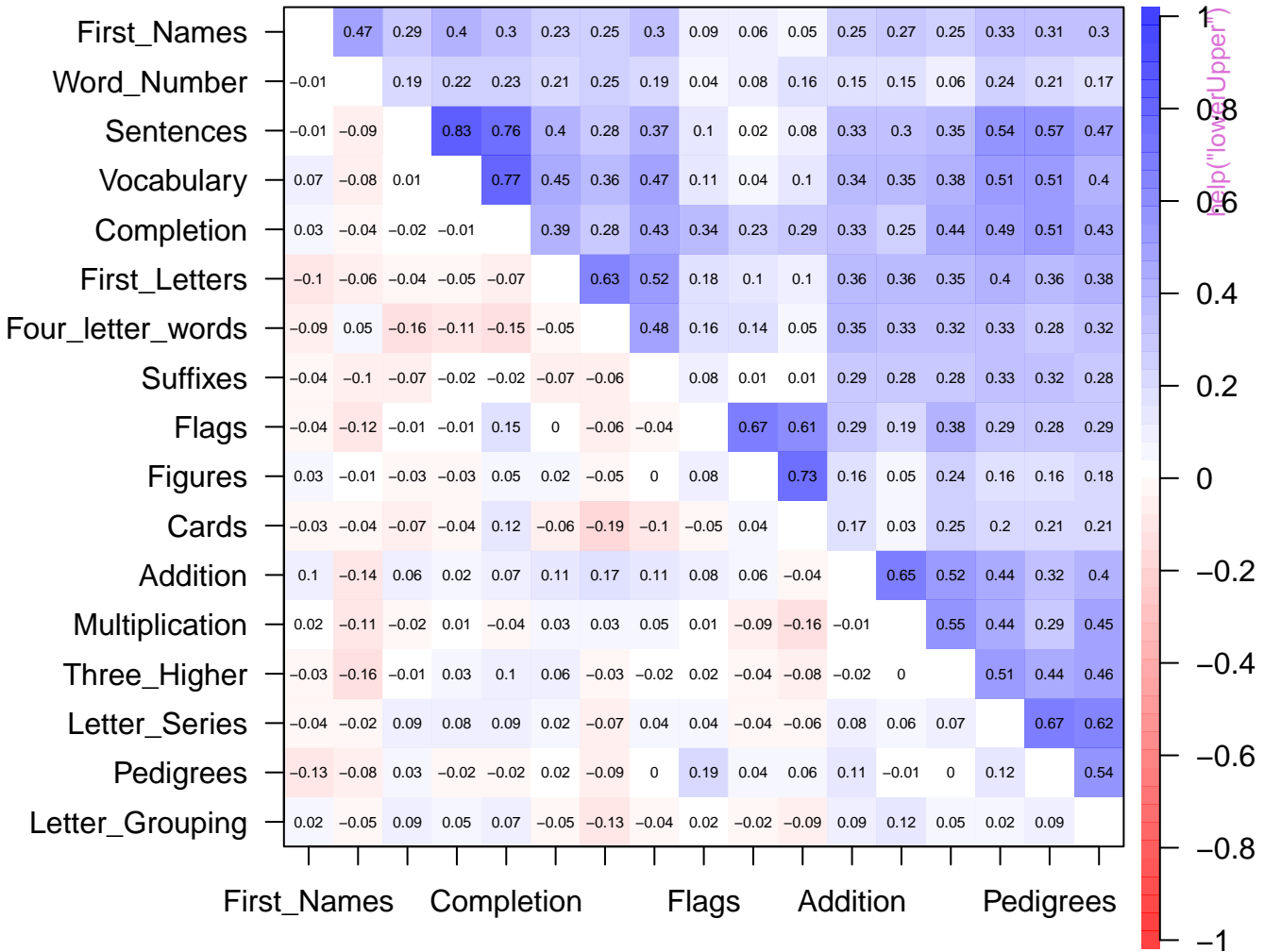

r and partial r for the sat.act data set

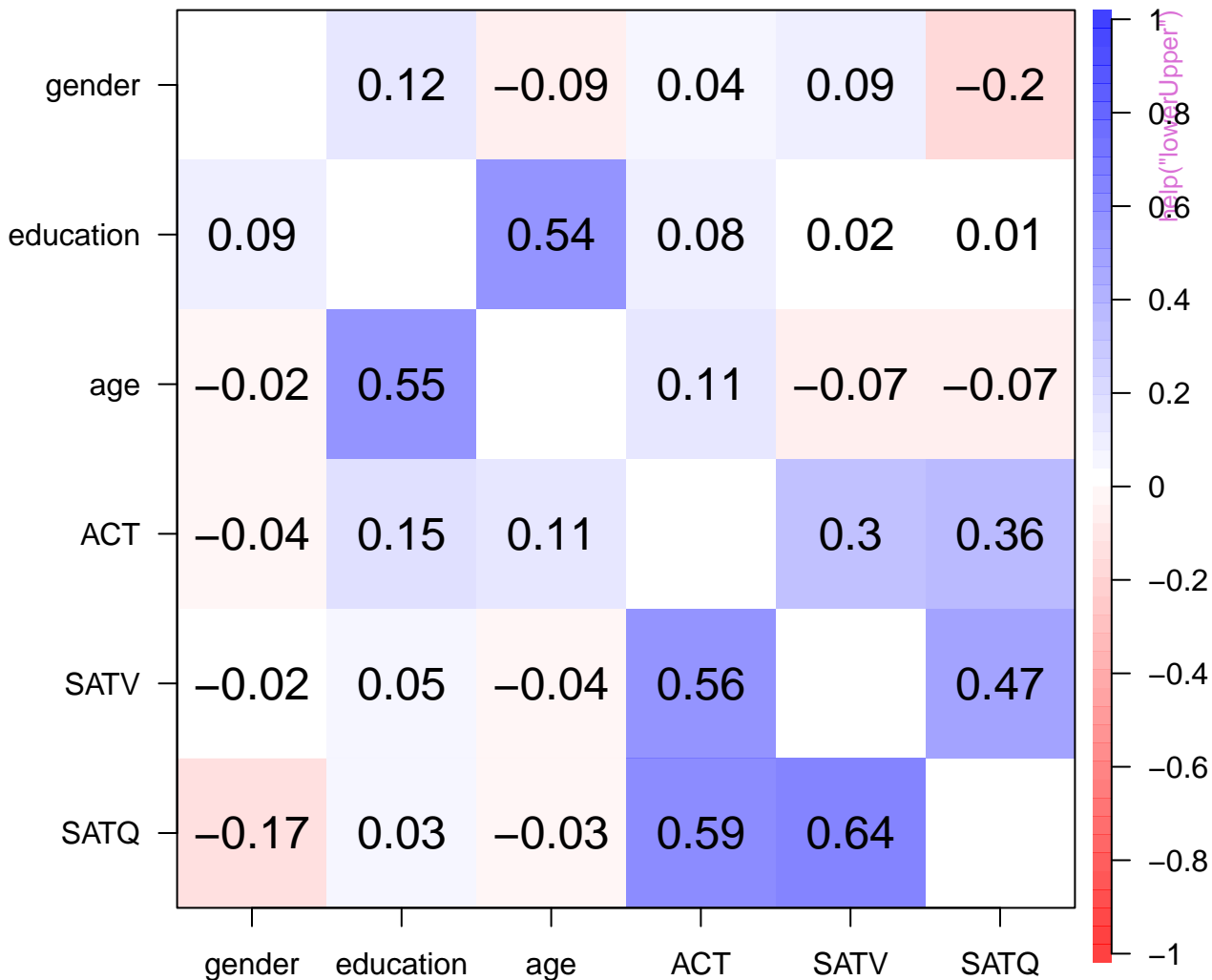

Differences between r and partial r for the sat.act data se

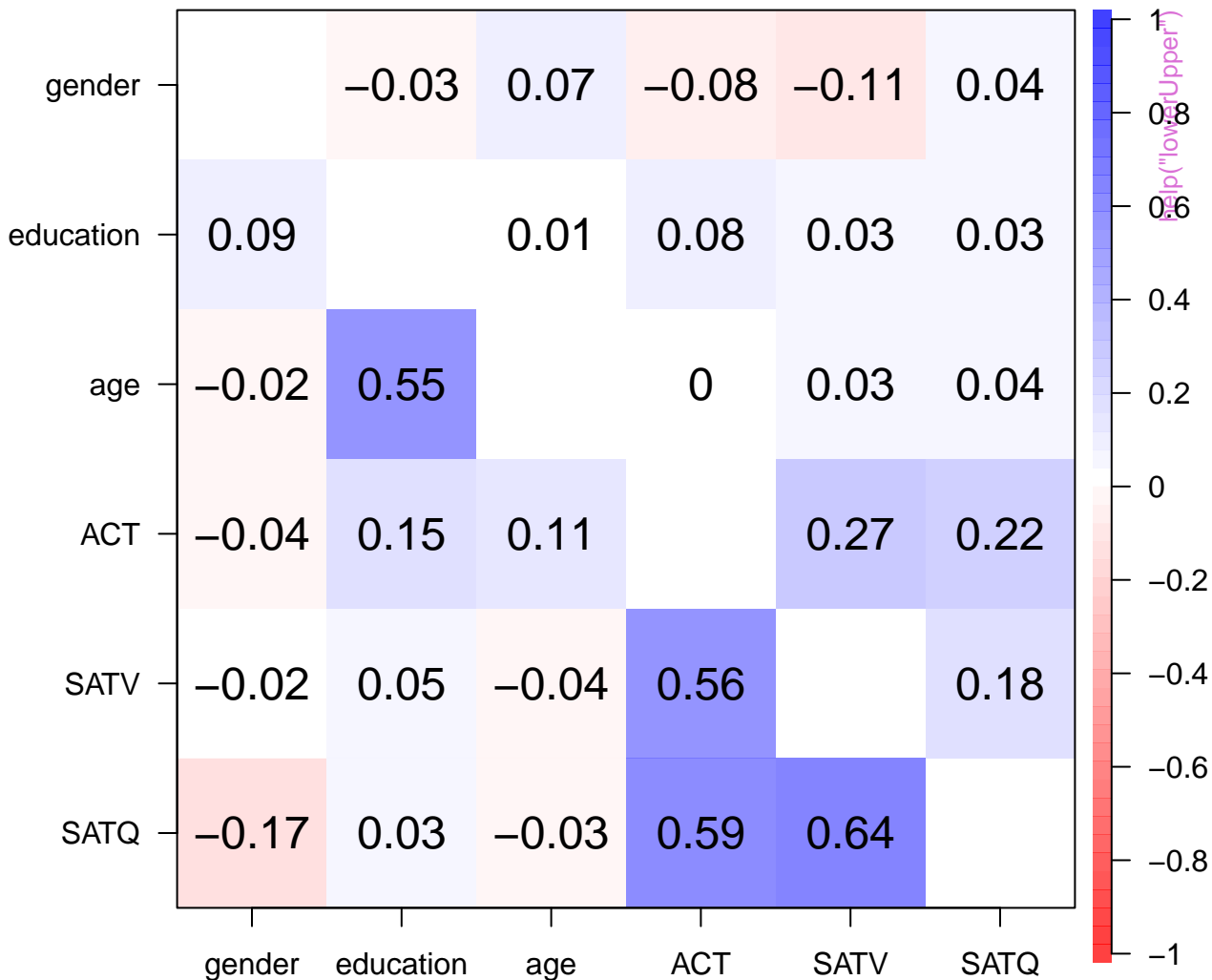

Manhattan Plot of gender

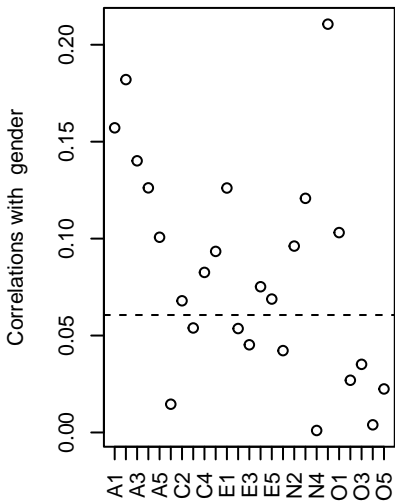

Manhattan Plot of education

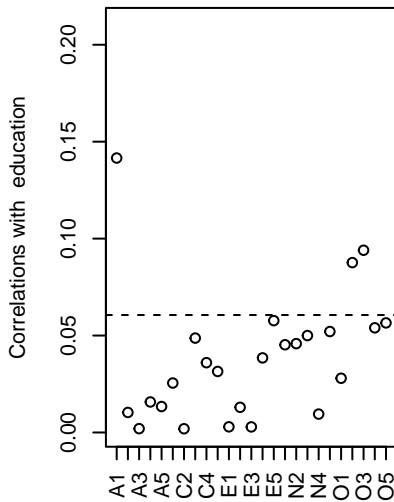

Manhattan Plot of age

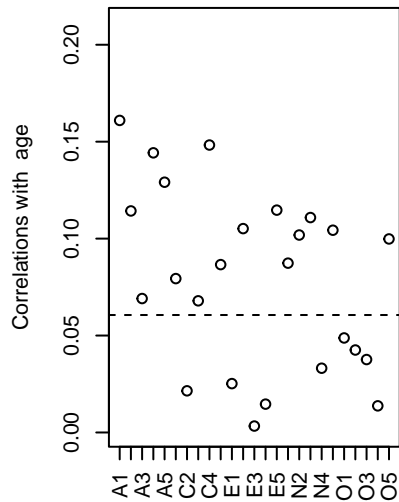

Manhattan Plot of gender

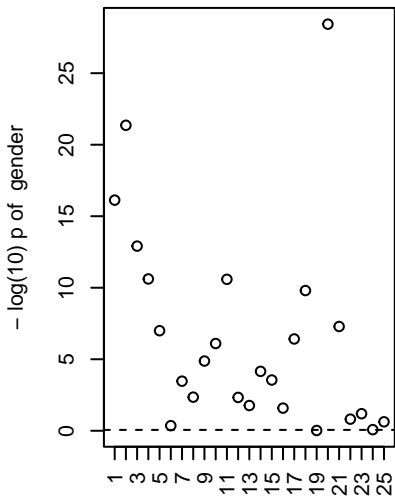

Manhattan Plot of education

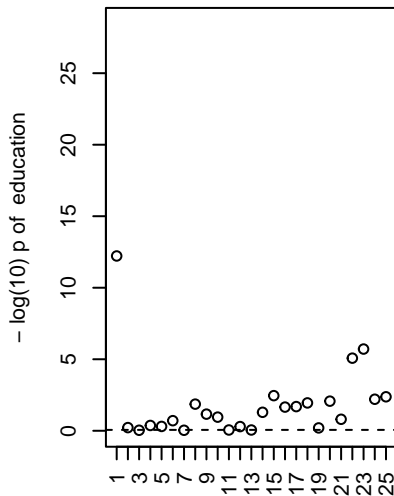

Manhattan Plot of age

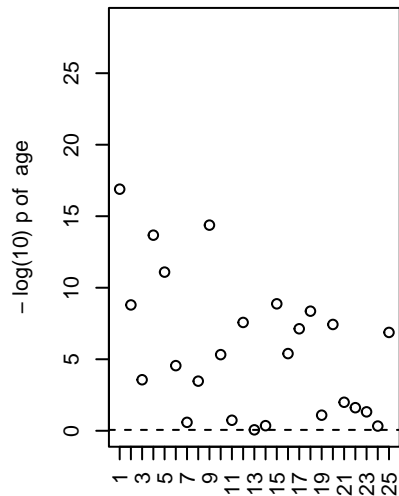

help("manhattan")

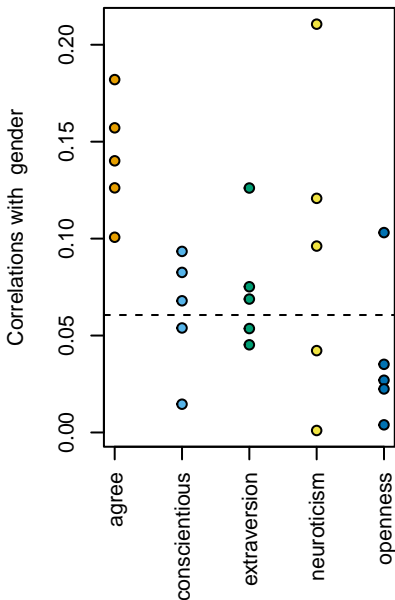
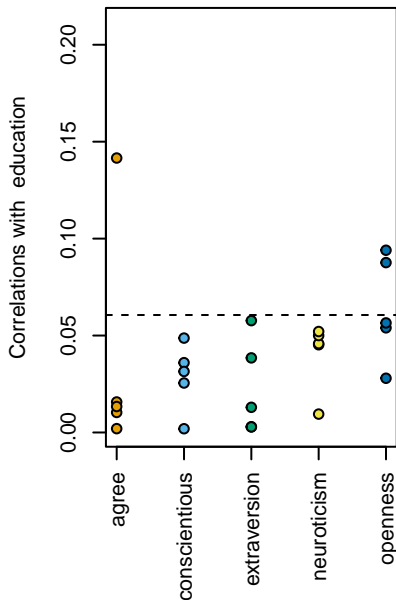
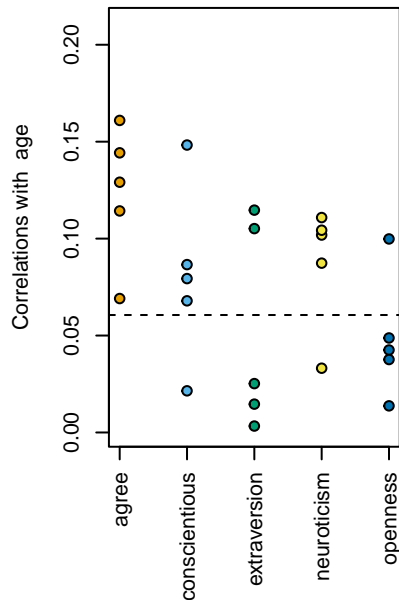
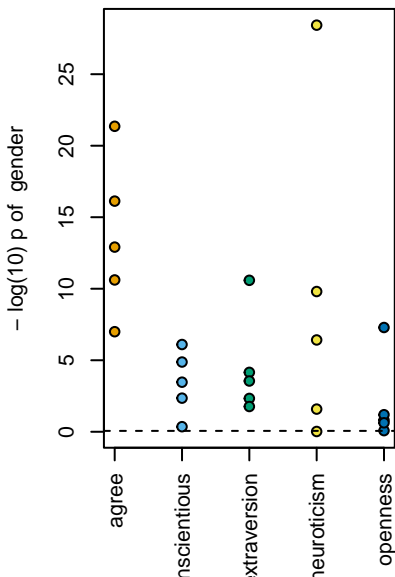
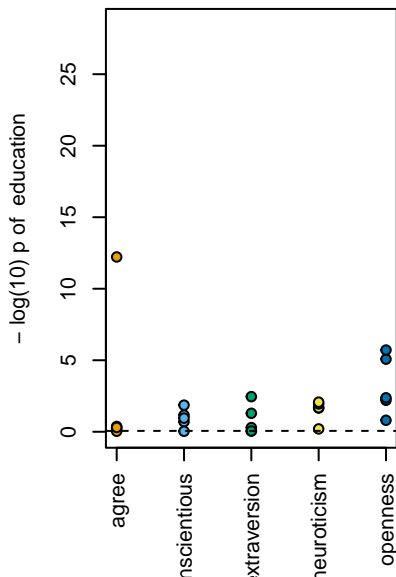
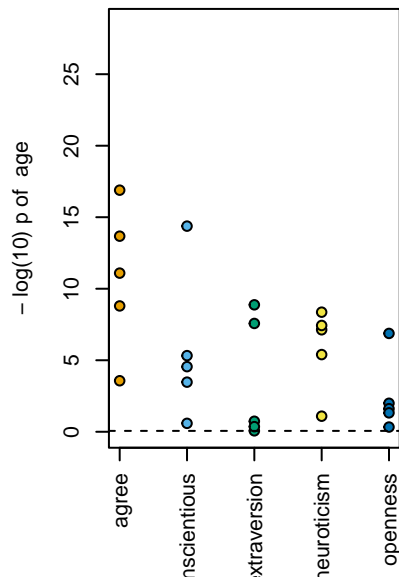
Manhattan Plot of gender**Manhattan Plot of education****Manhattan Plot of age****Manhattan Plot of gender****Manhattan Plot of education****Manhattan Plot of age**

help("manhattan")

Manhattan Plot of gender

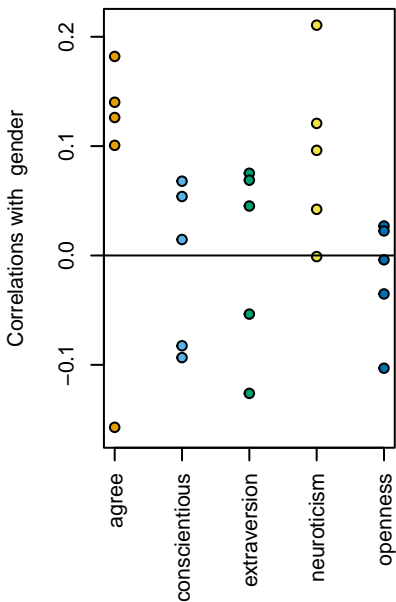

Manhattan Plot of education

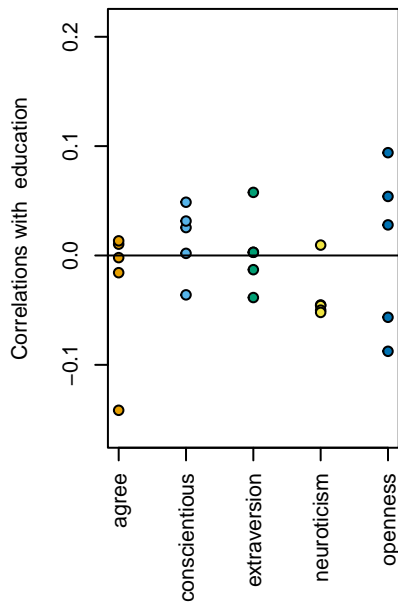

Manhattan Plot of age

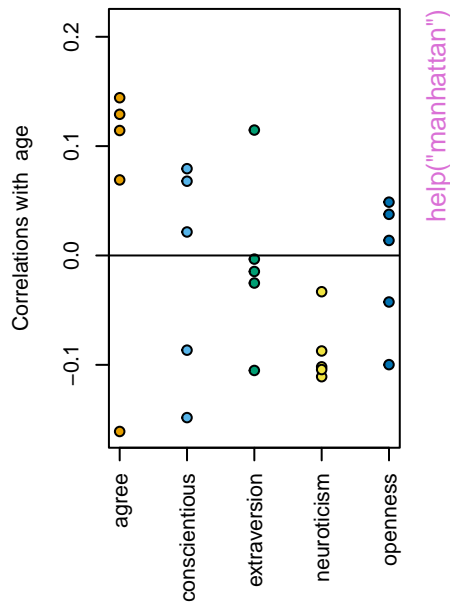

help("manhattan")

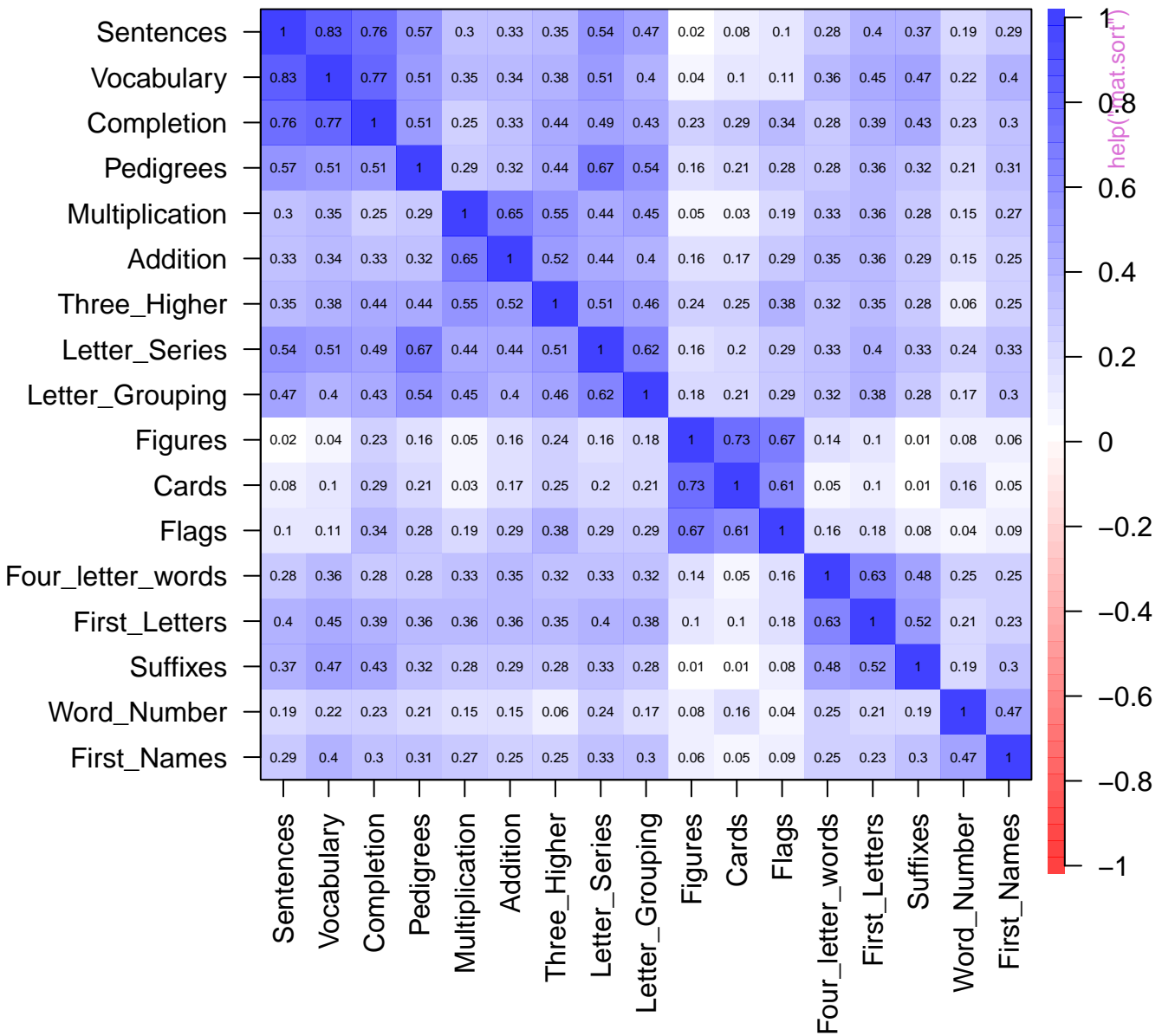

Mediation

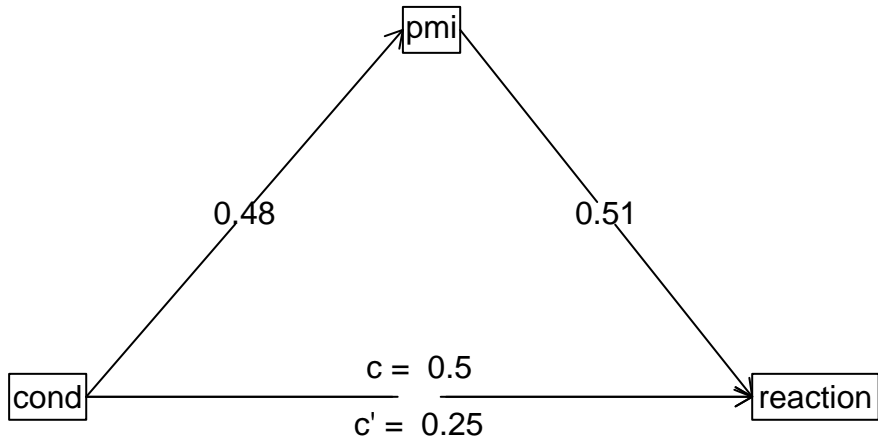

Mediation

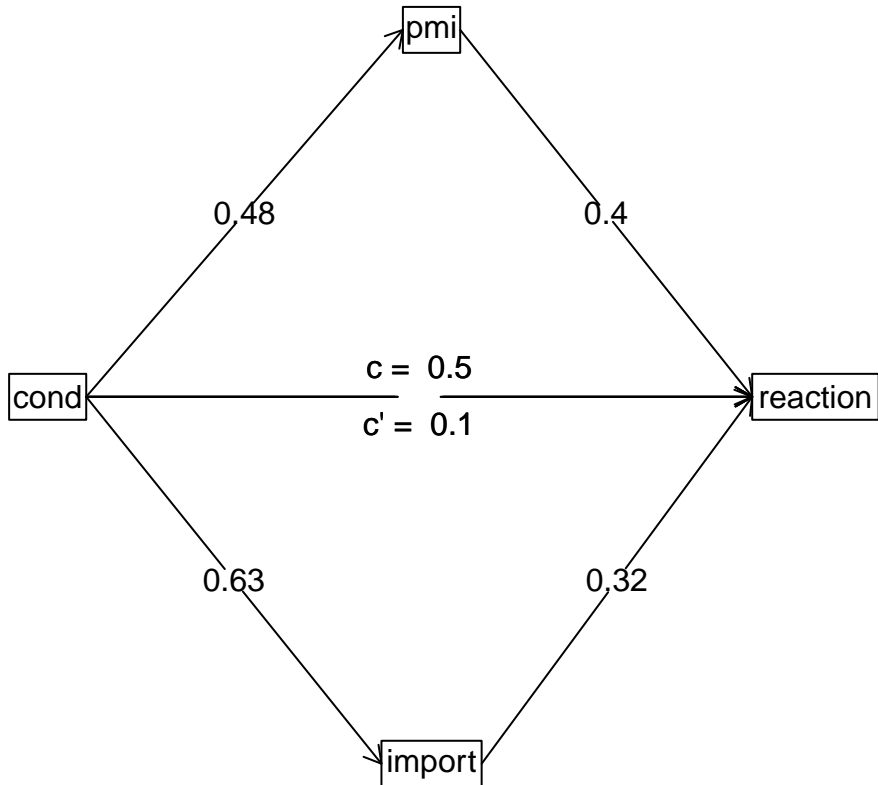

Moderation model

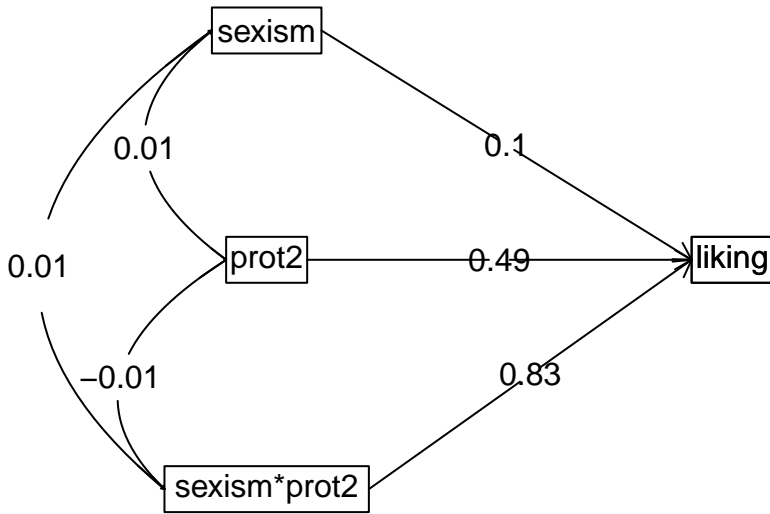

Mediation

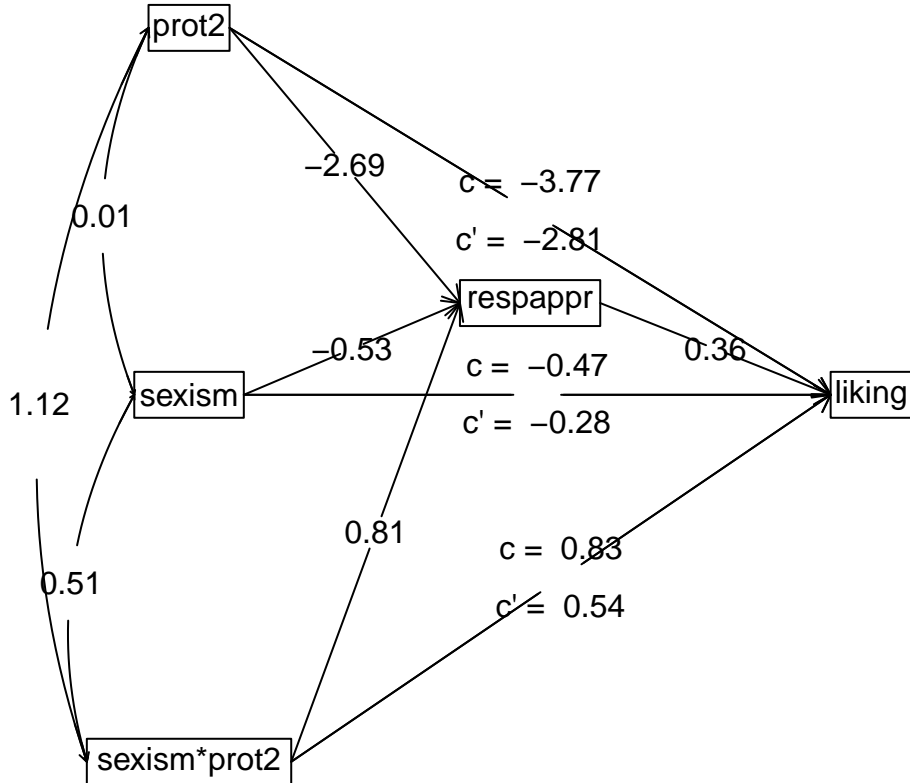

Mediation

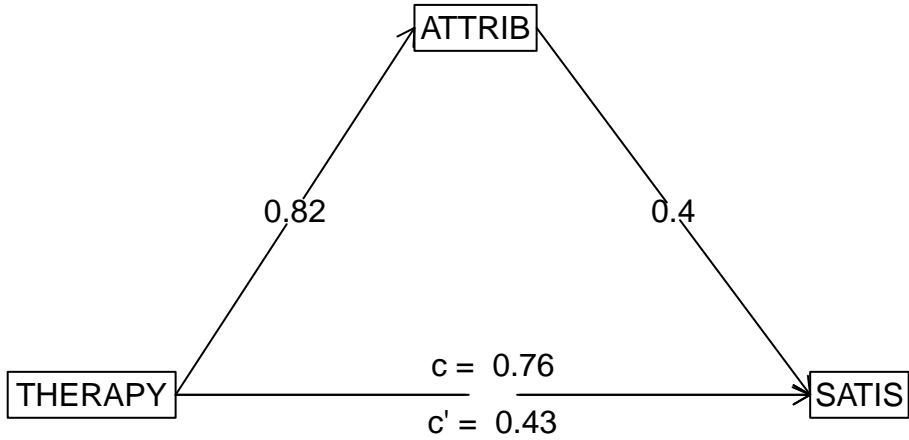

Mediation

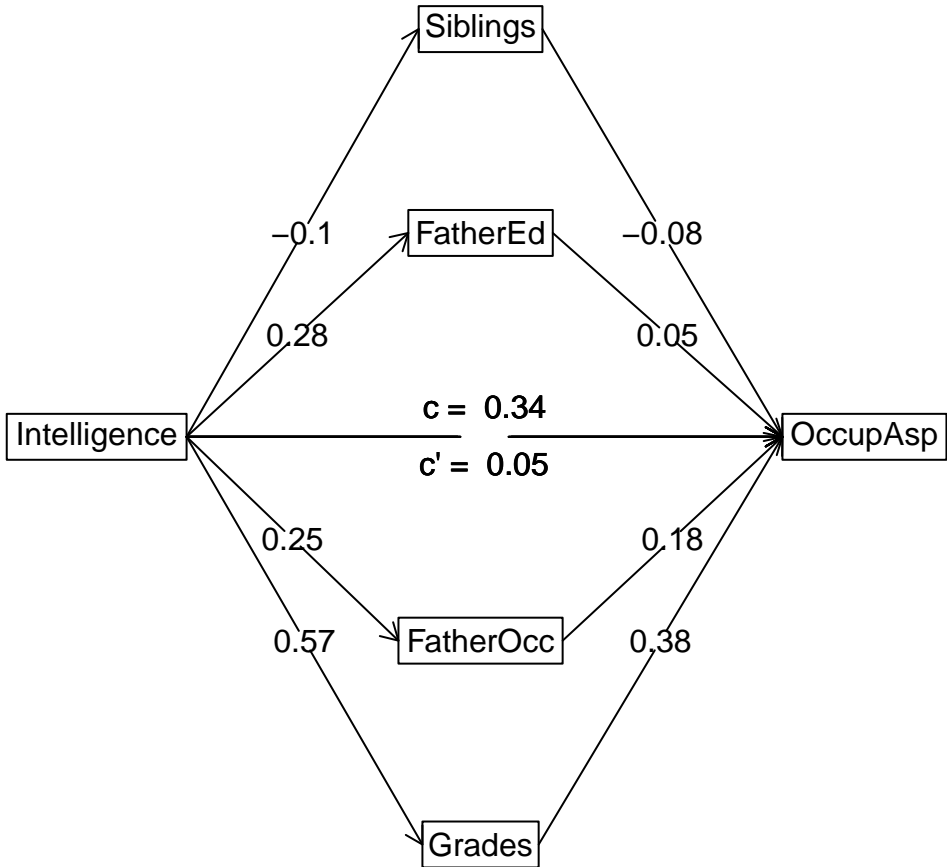

Mediation model

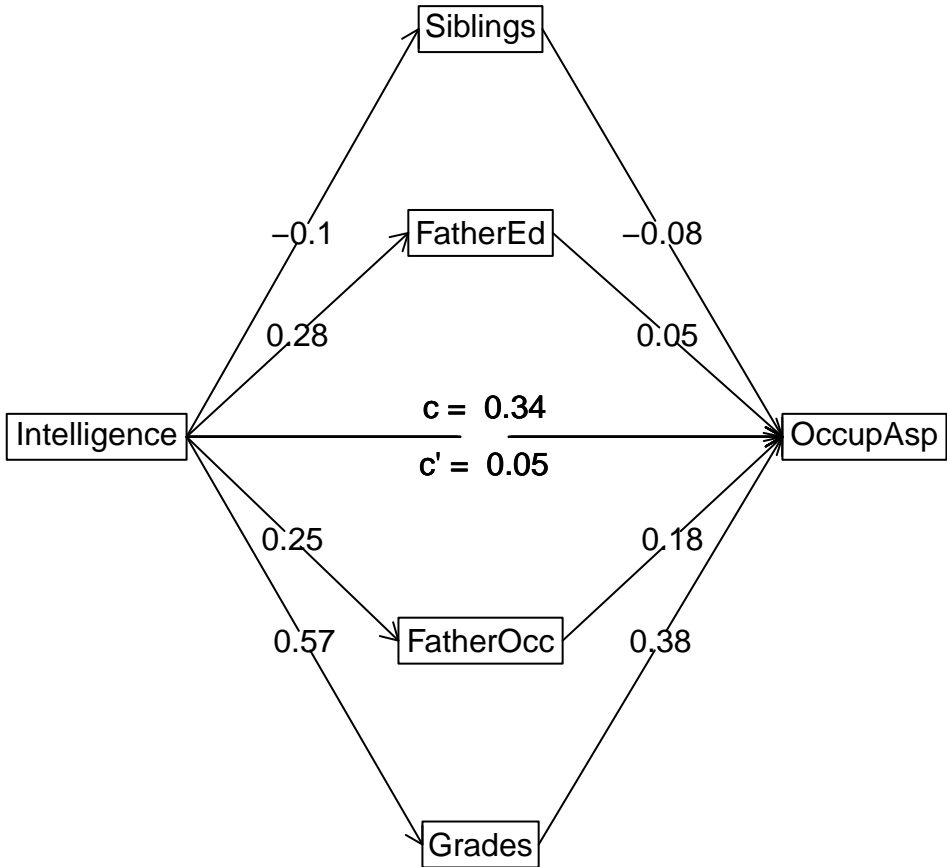

Mediation

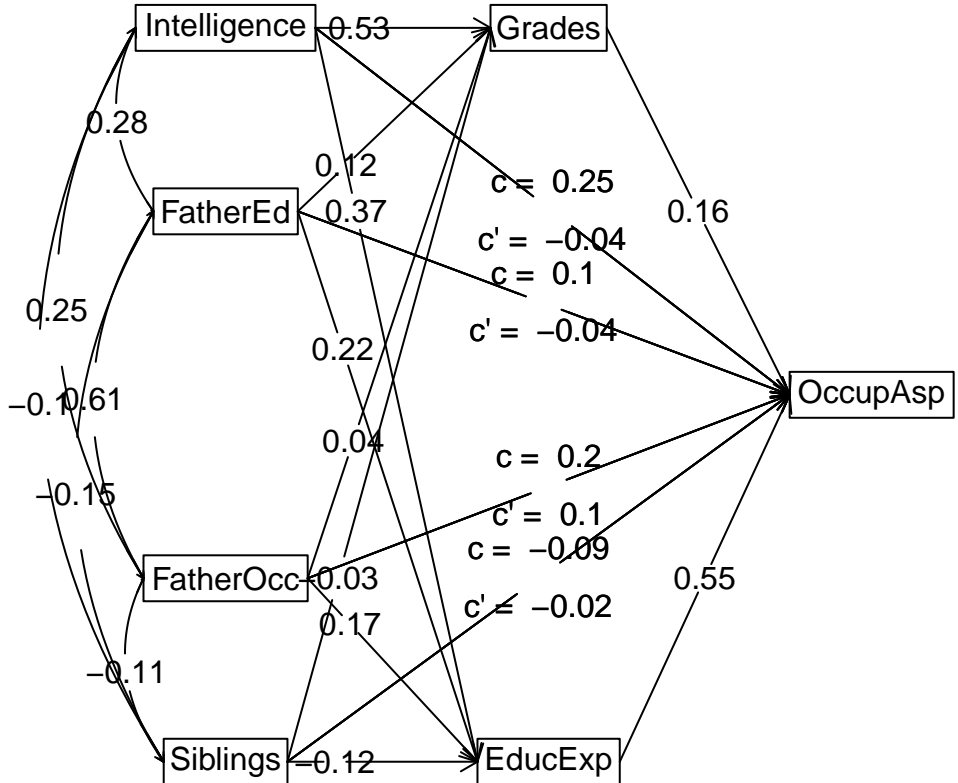

Mediation model

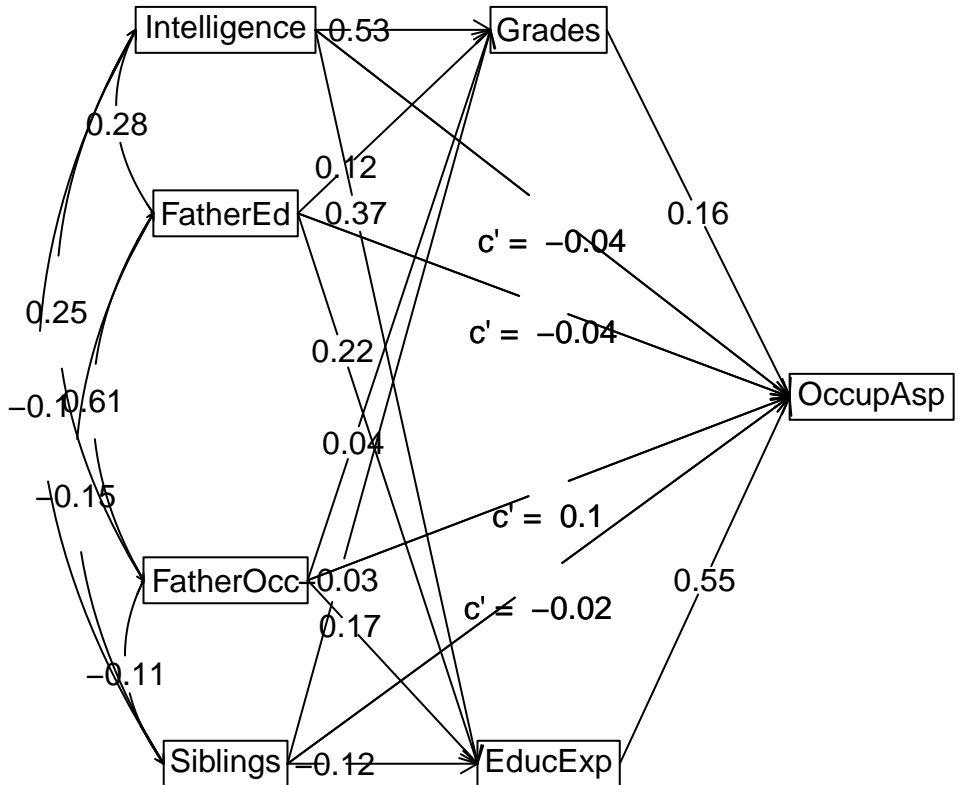

Mediation

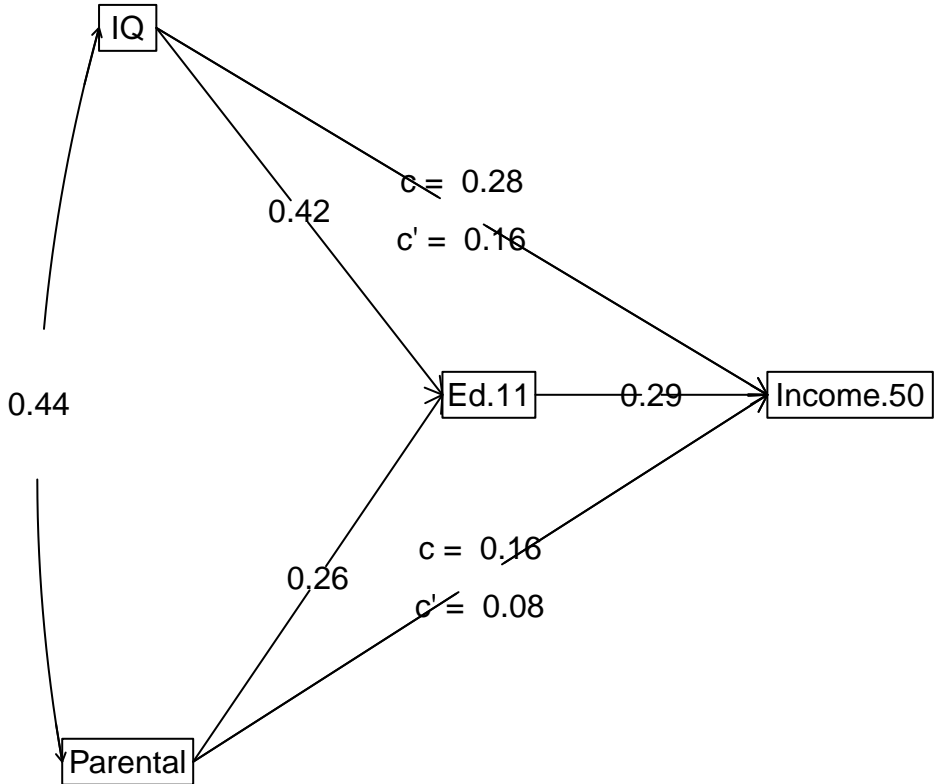

Mediation

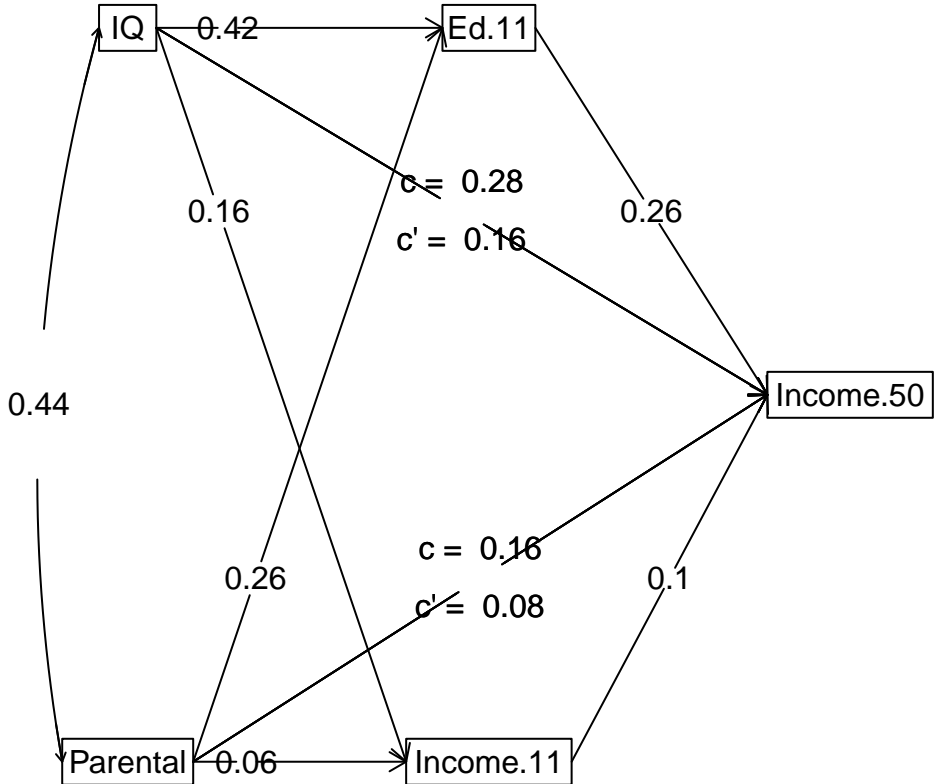

gender

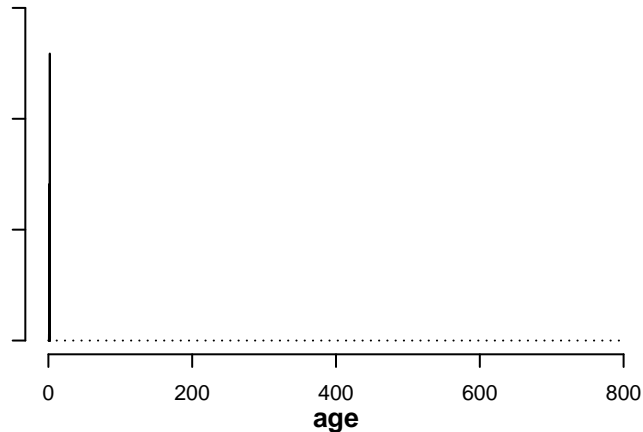

education

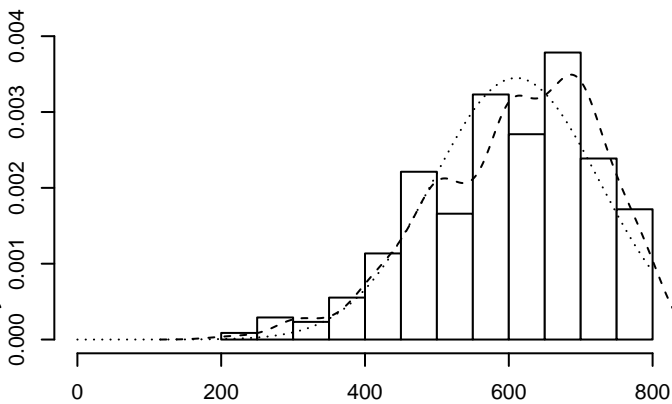
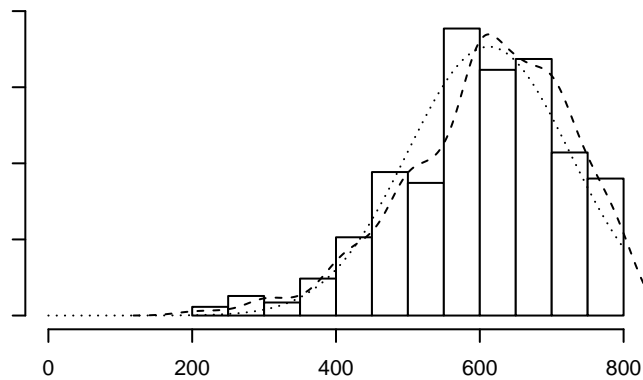
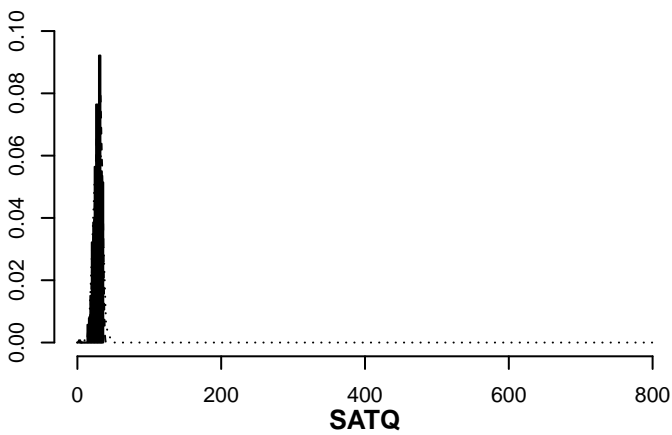
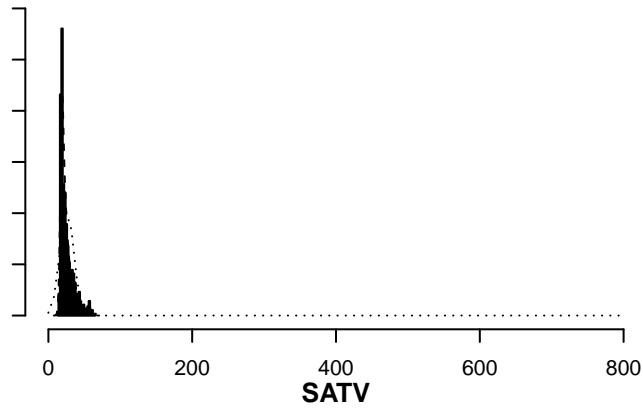
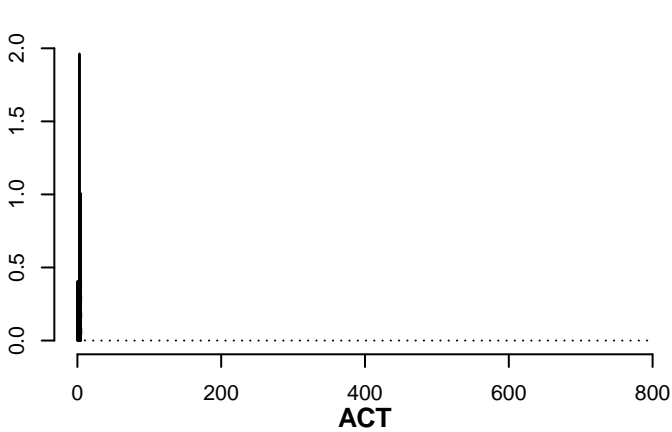

help("multi.hist")

gender

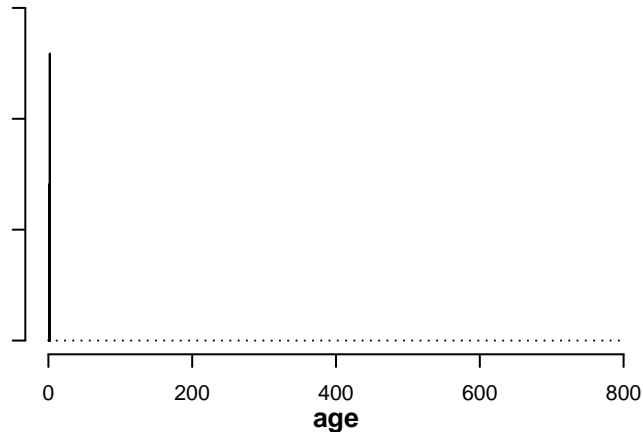

education

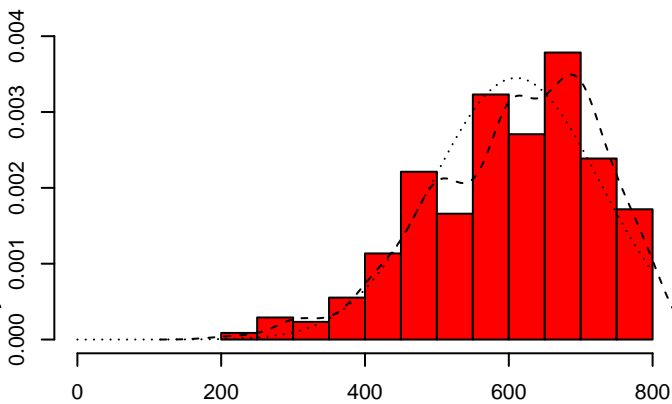
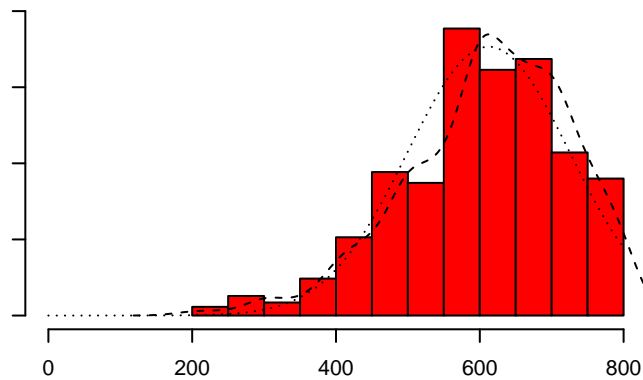
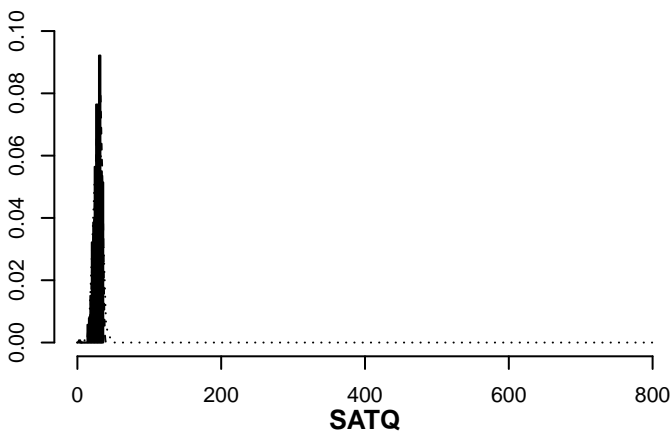
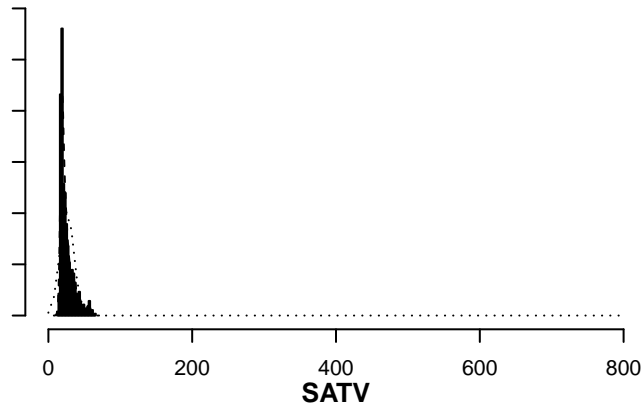
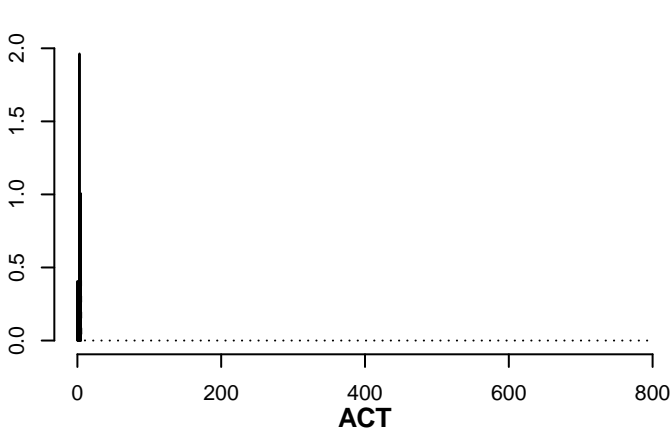

help("multi.hist")

gender

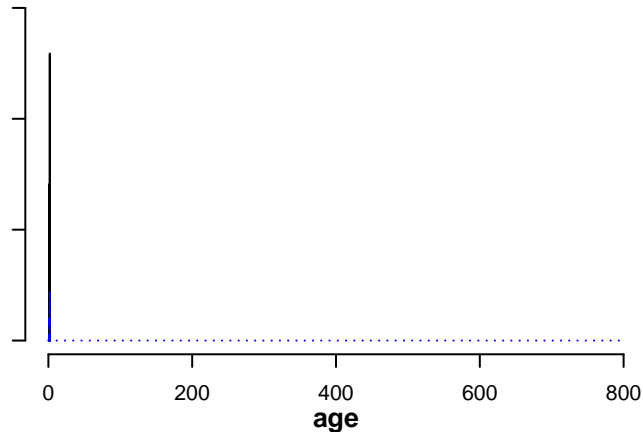

education

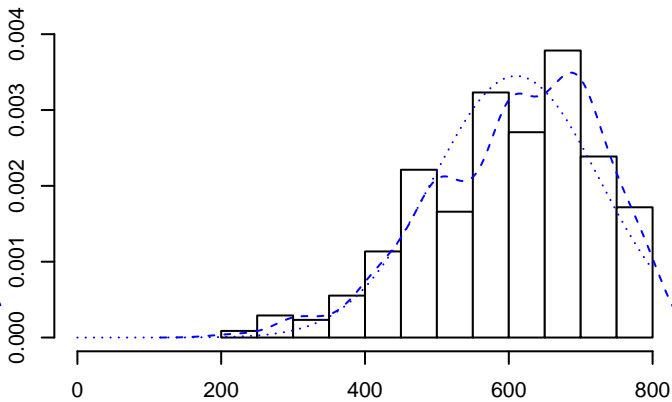
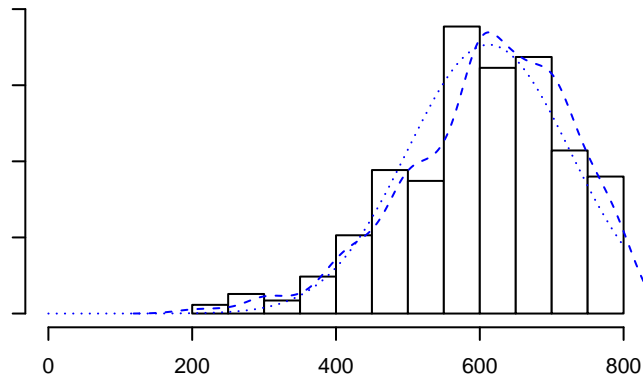
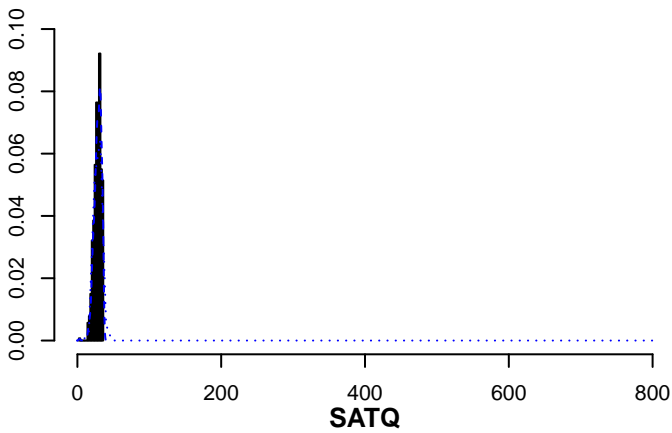
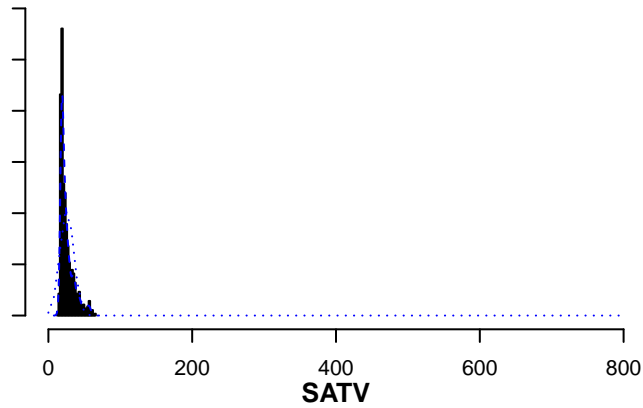
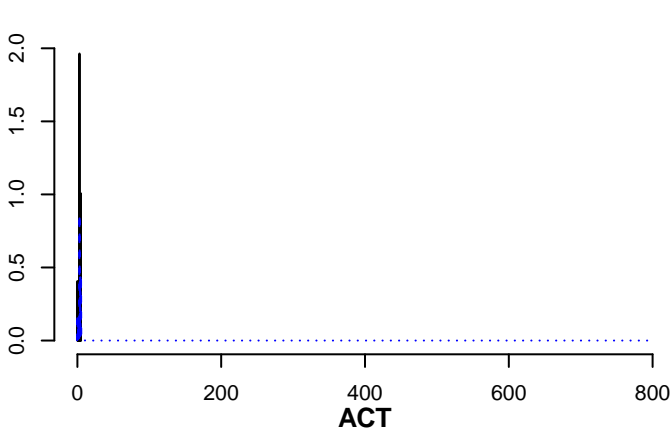

help("multi.hist")

gender

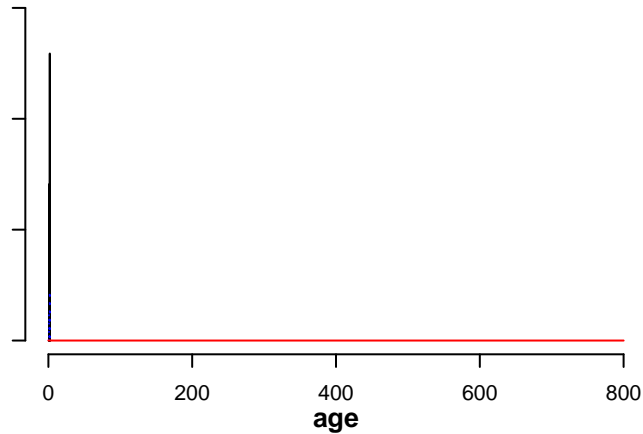

education

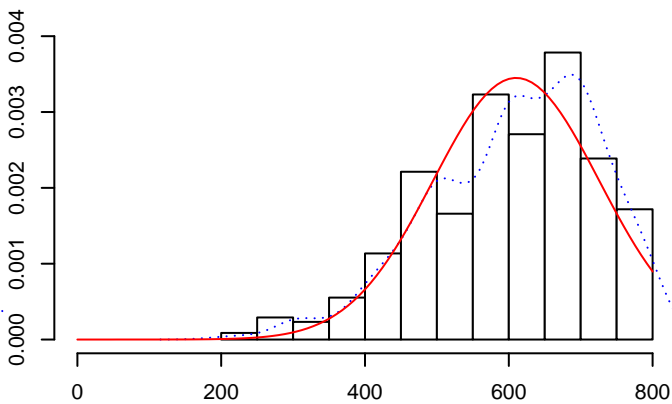
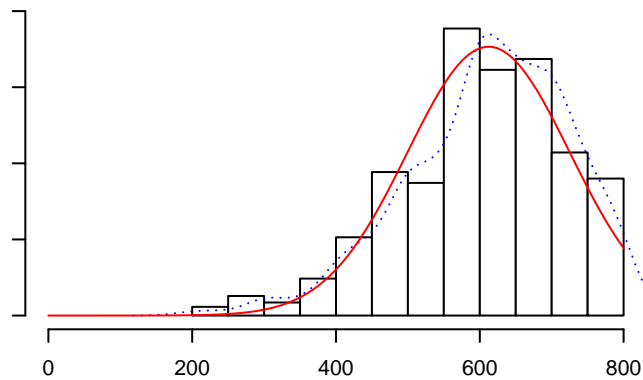
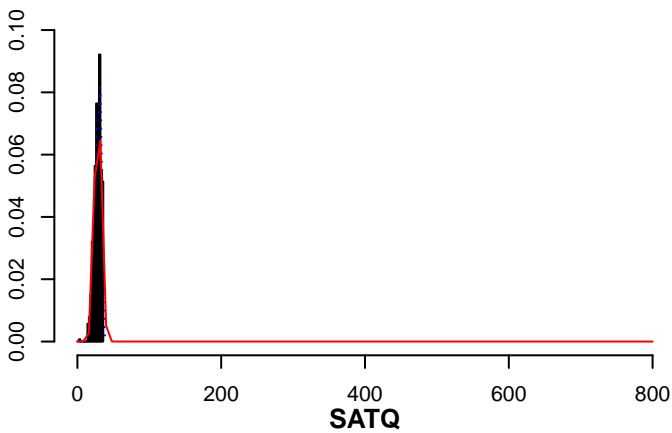
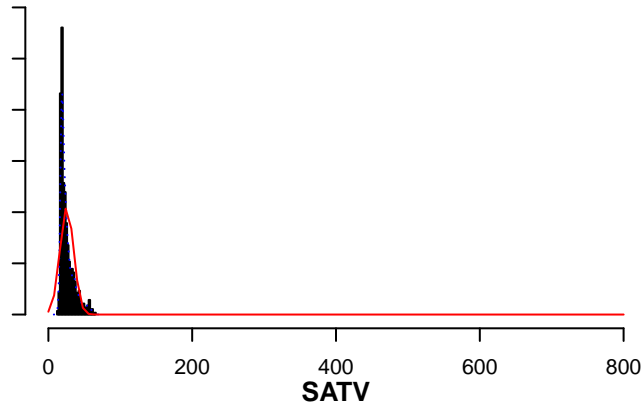
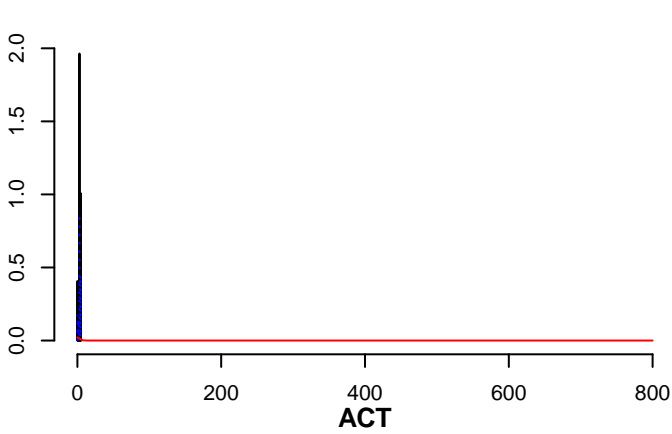

help("multi.hist")

gender

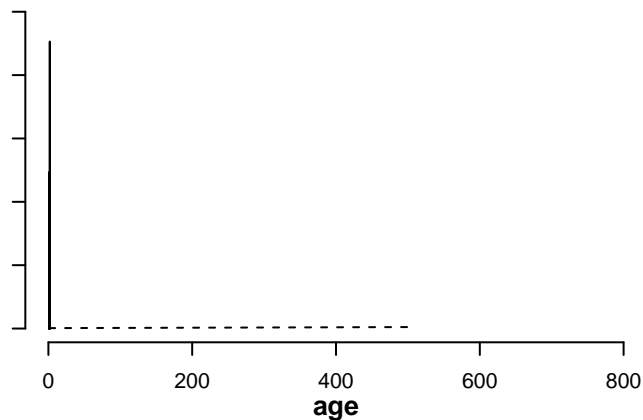

education

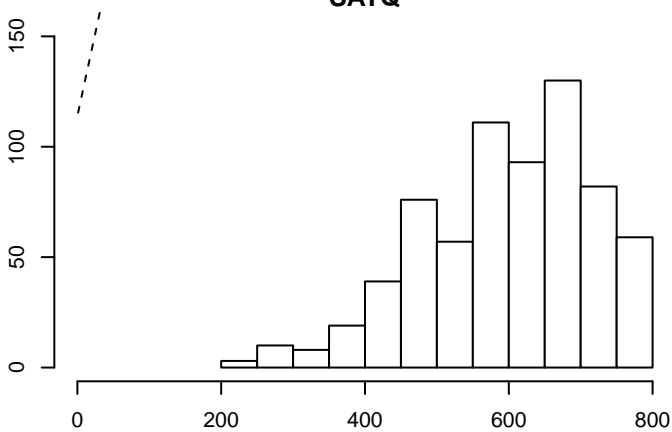
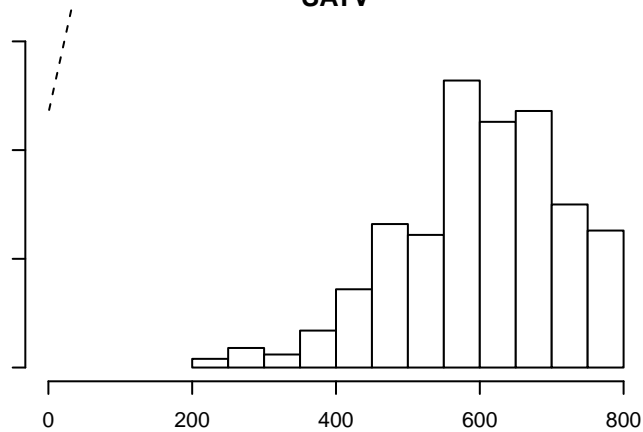
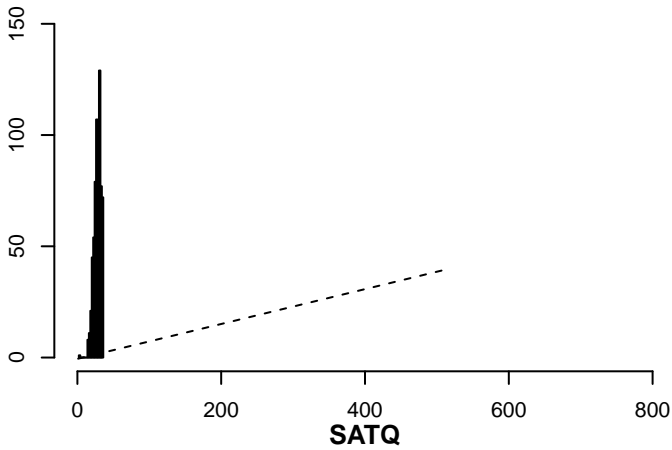
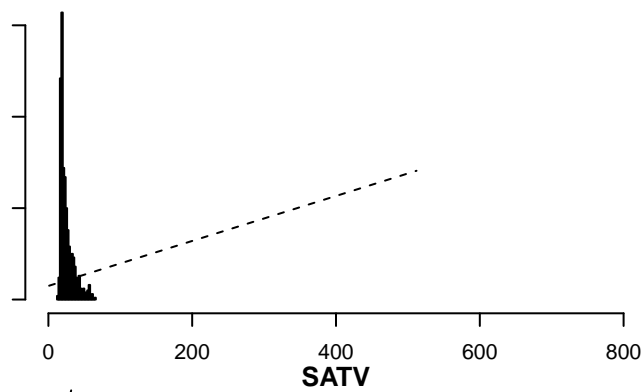
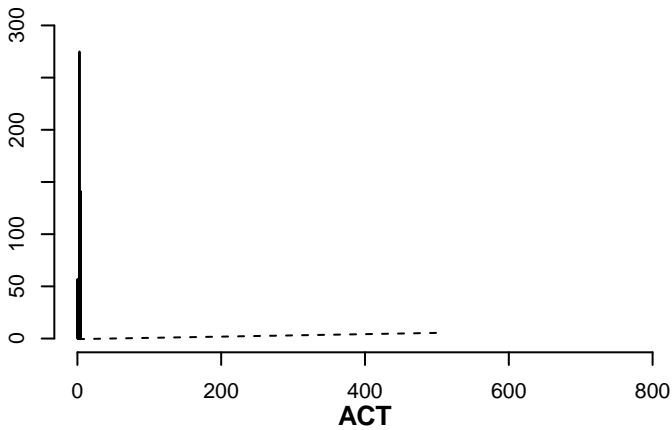

help("multi.hist")

gender

education

age

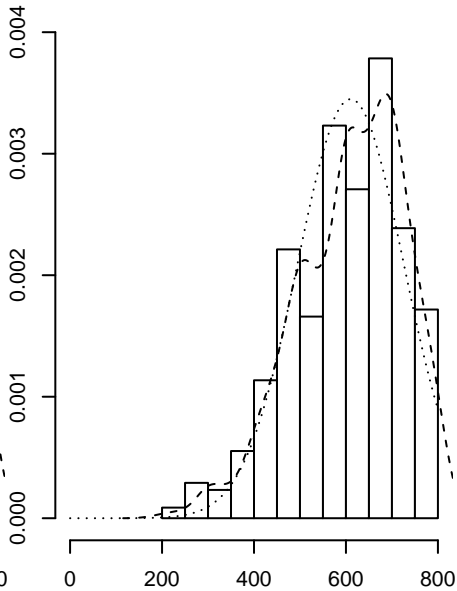
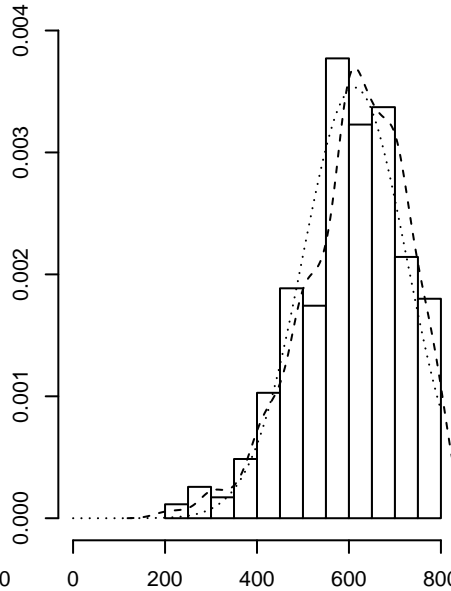
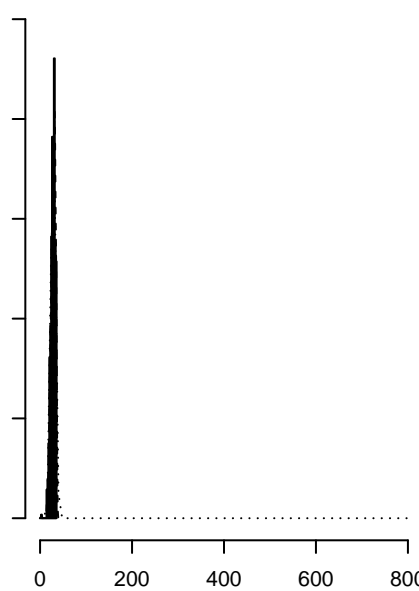
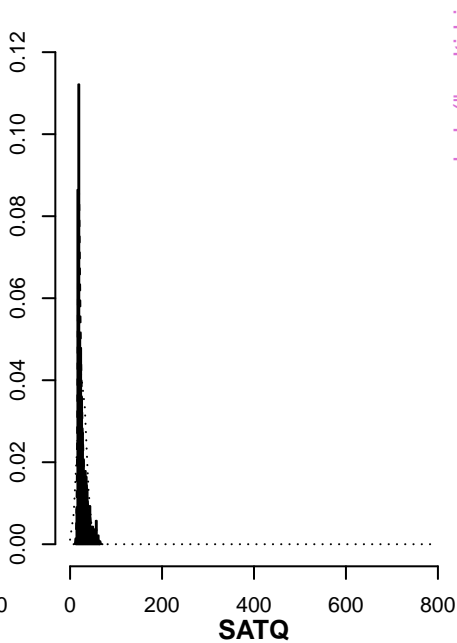
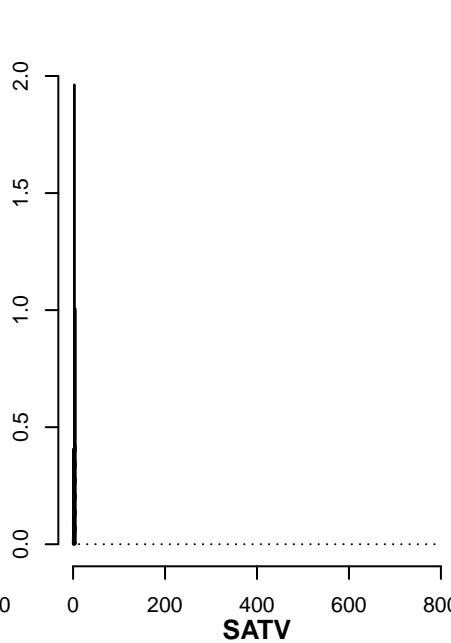
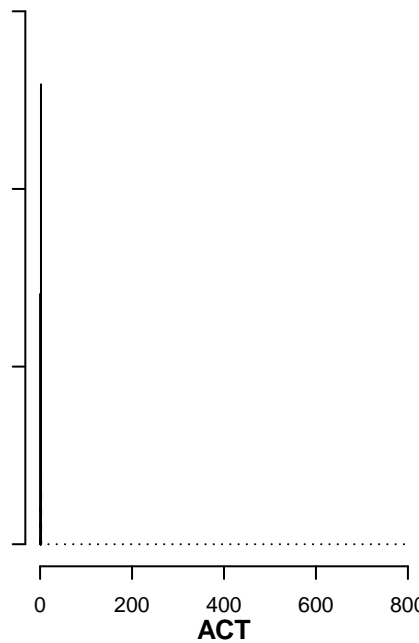

help("multi.hist")

Histograms by group

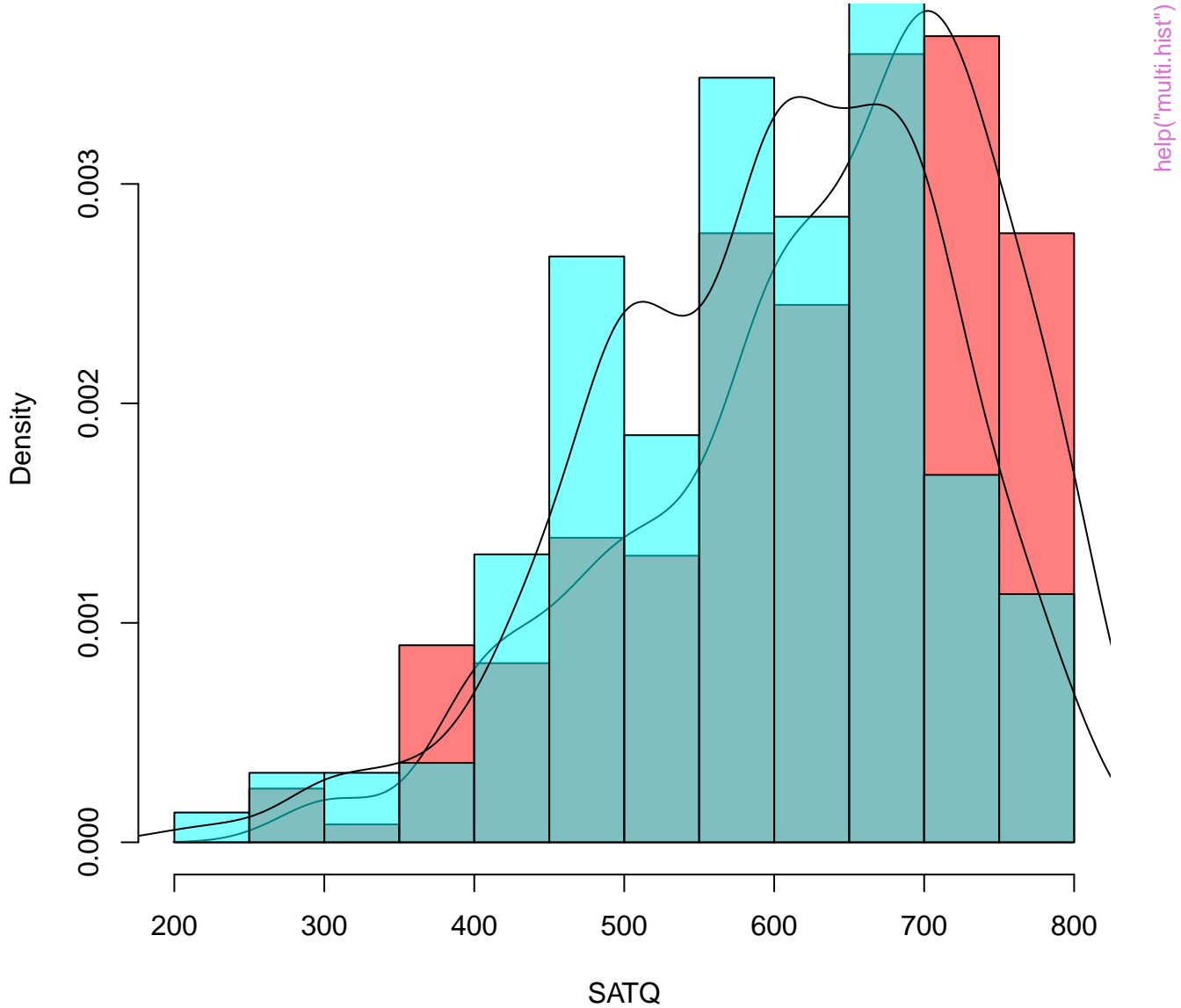

Histograms by group

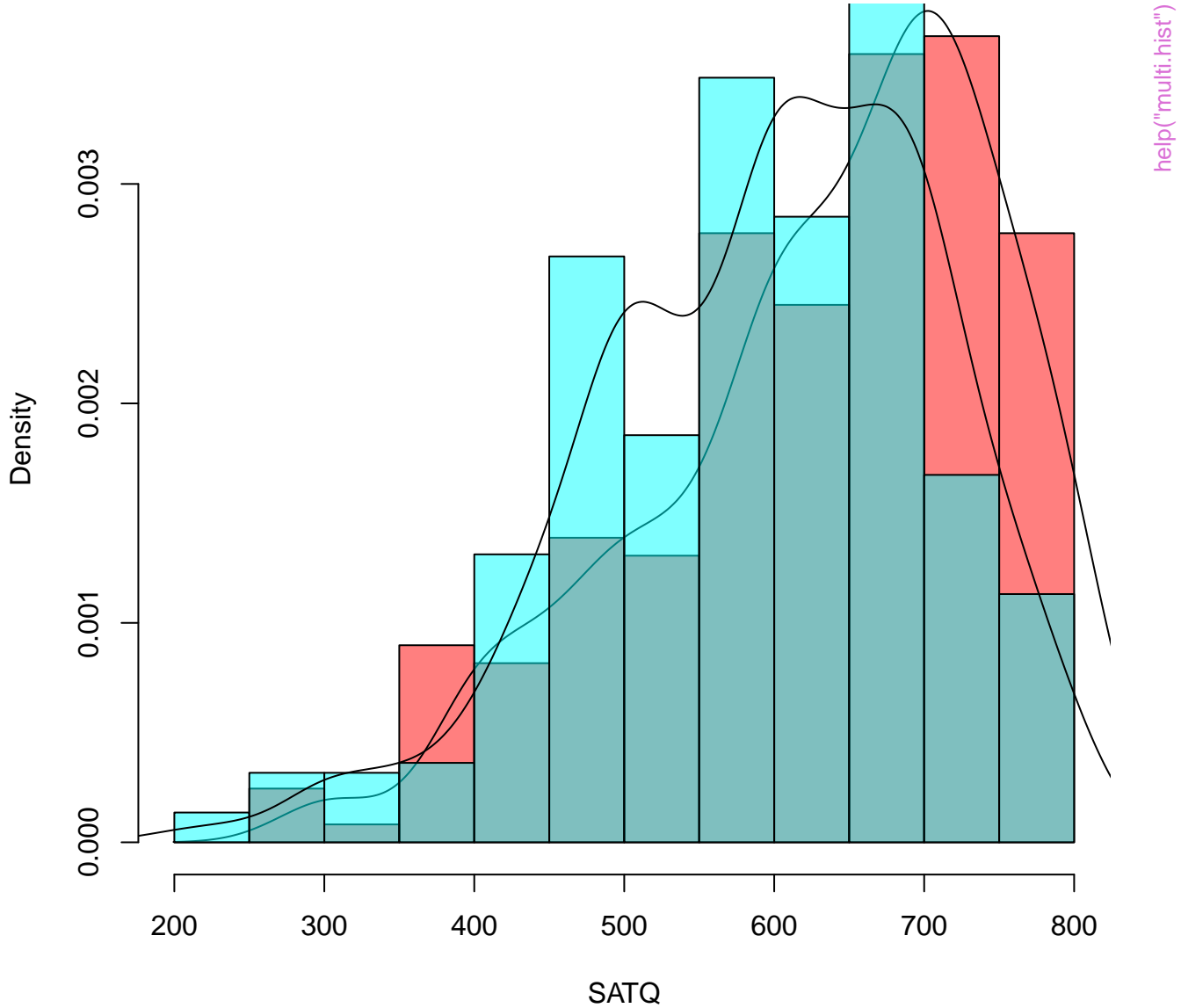

Omega

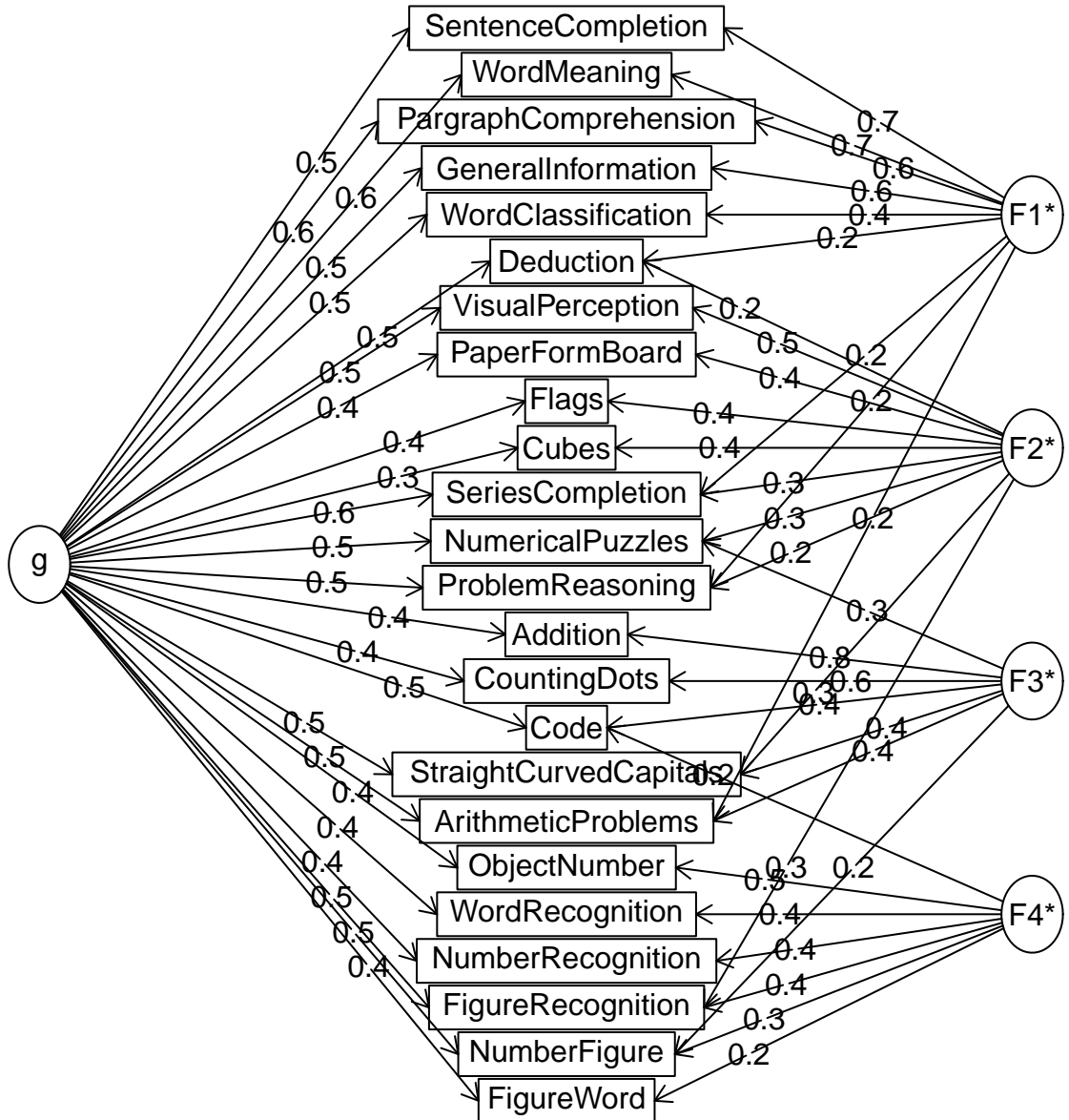

Omega

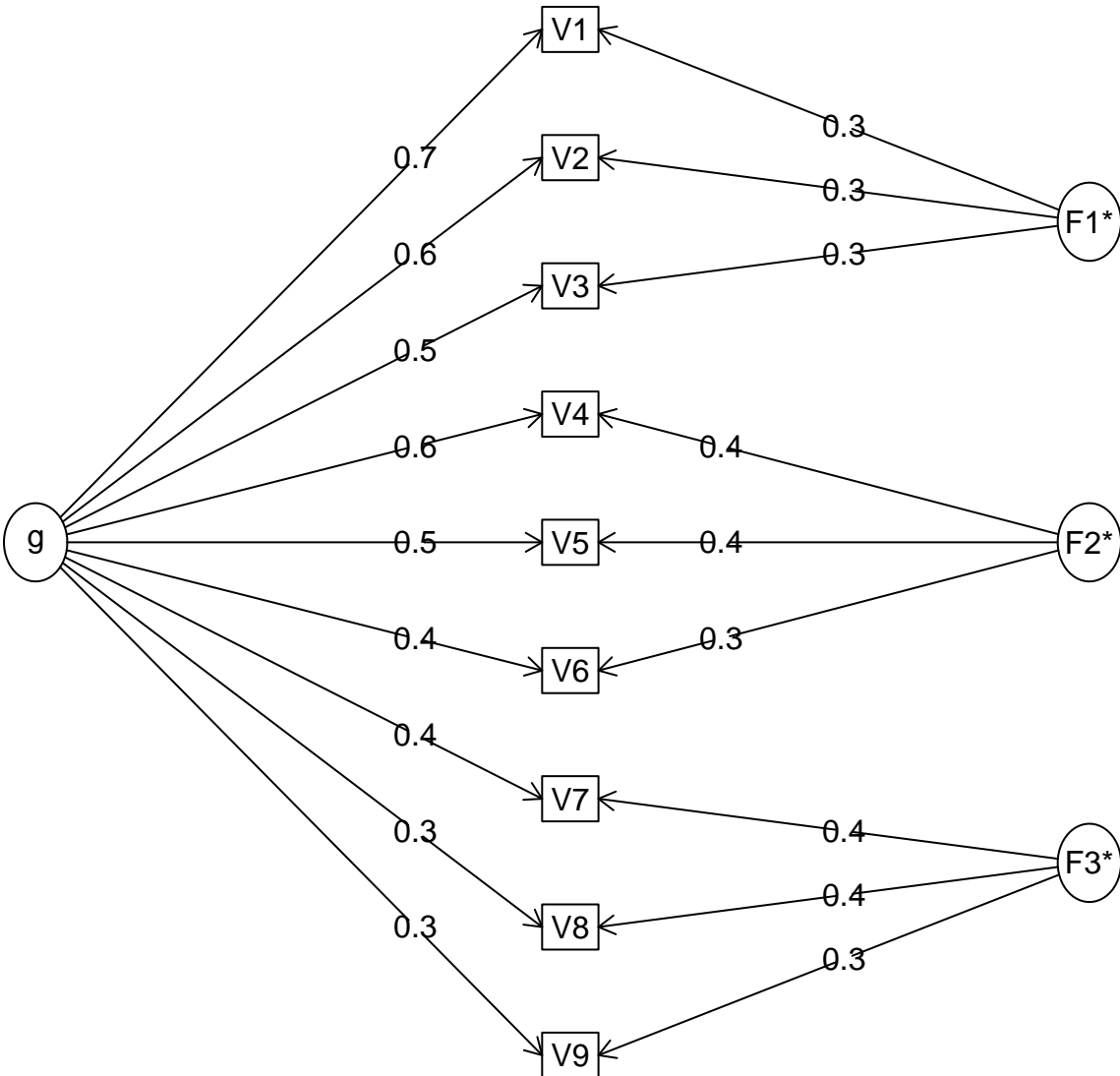

Q-Q plot of Mahalanobis D^2 vs. quantiles of χ^2_{nvar}

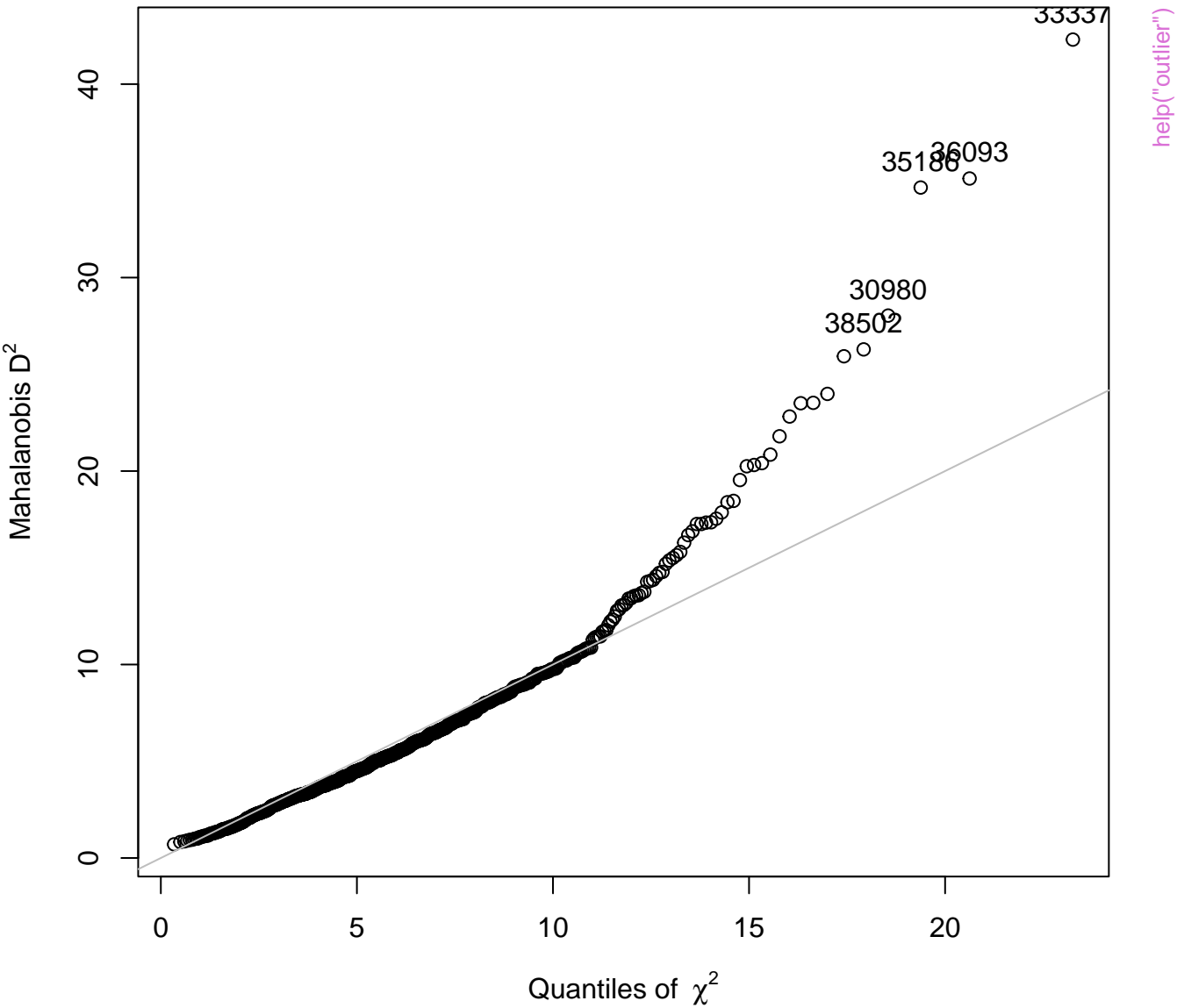

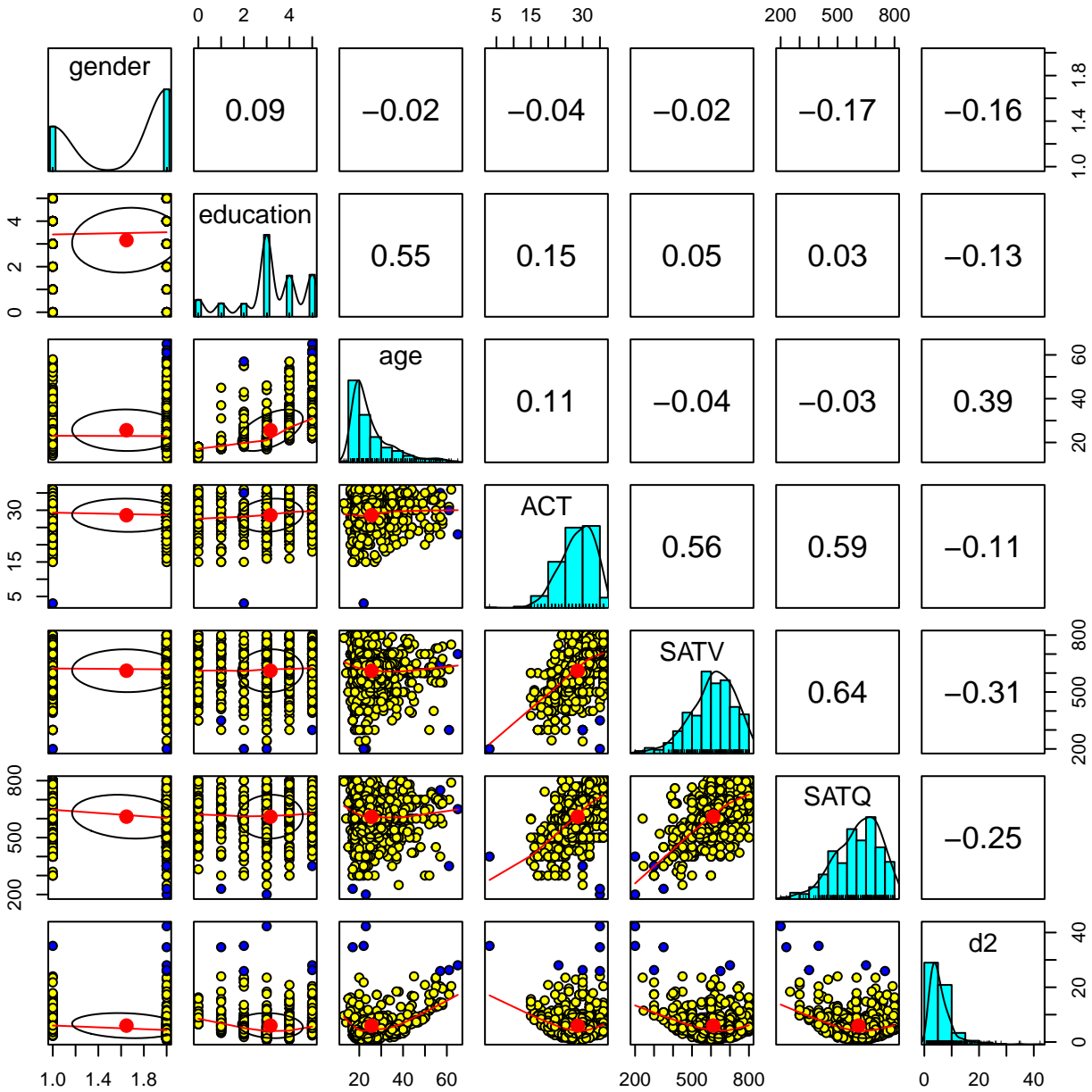

help("outlier")

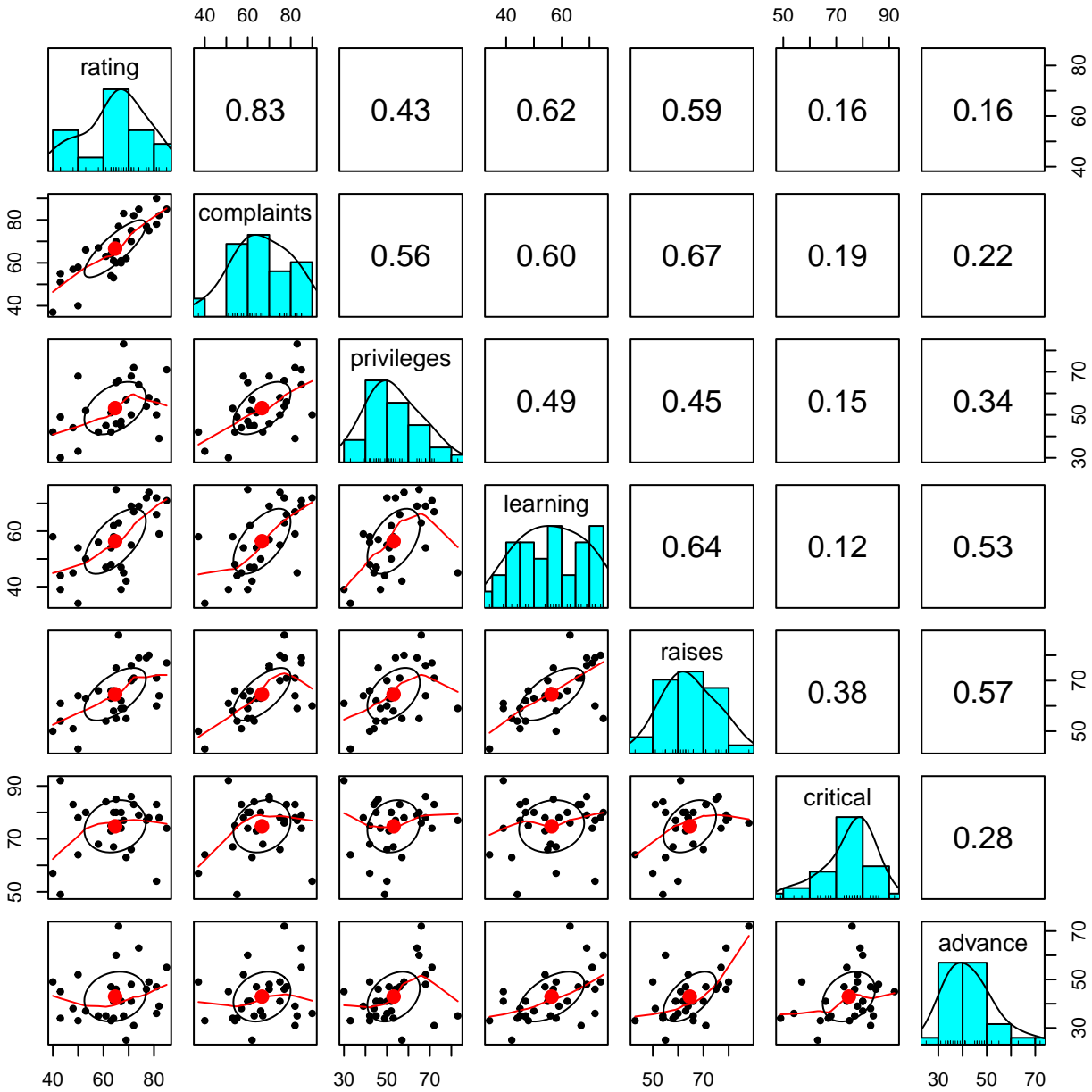

help("pairs.panels")

Fisher Iris data by Species

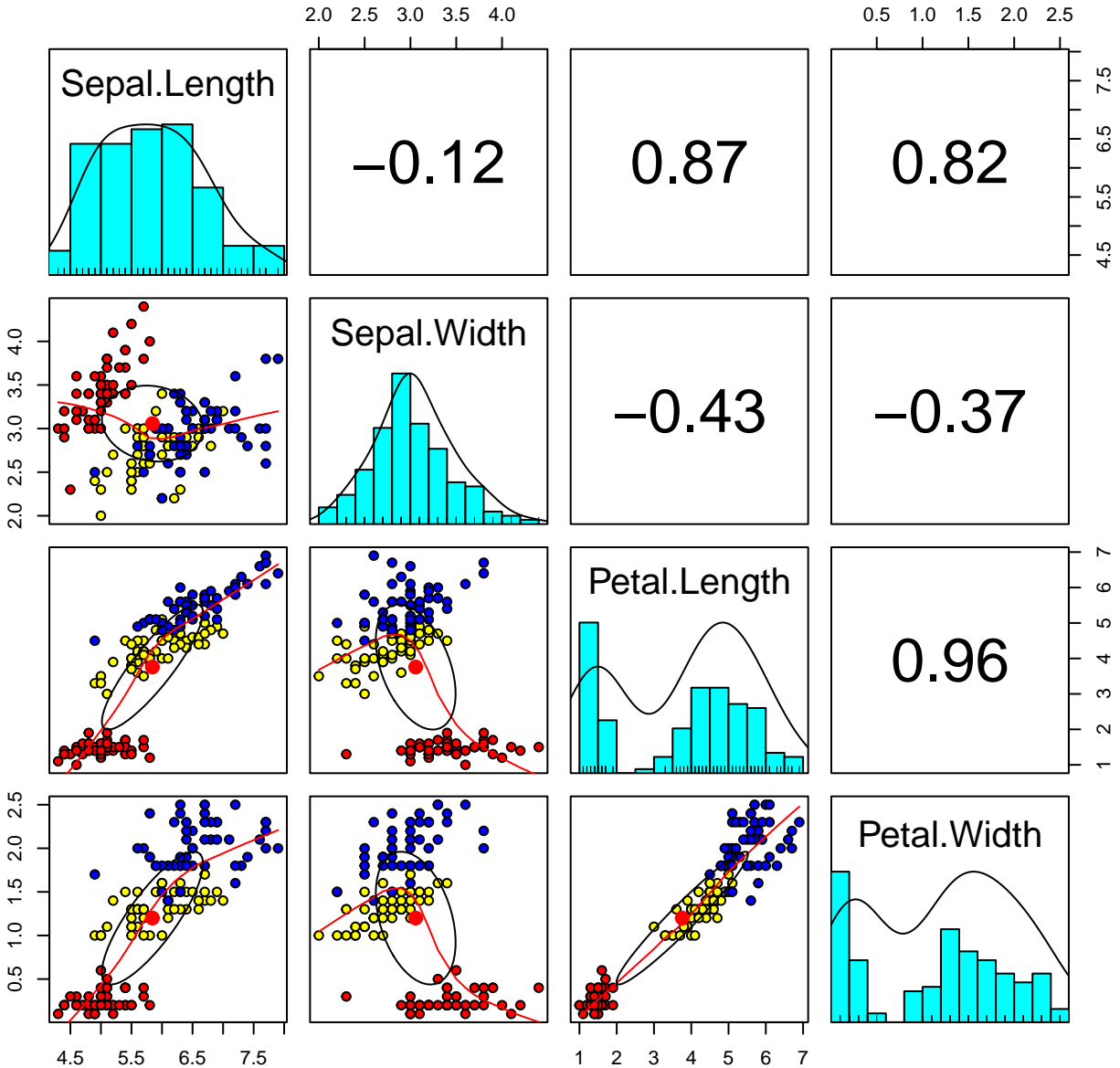

help("pairs.panels")

Fisher Iris data by Species

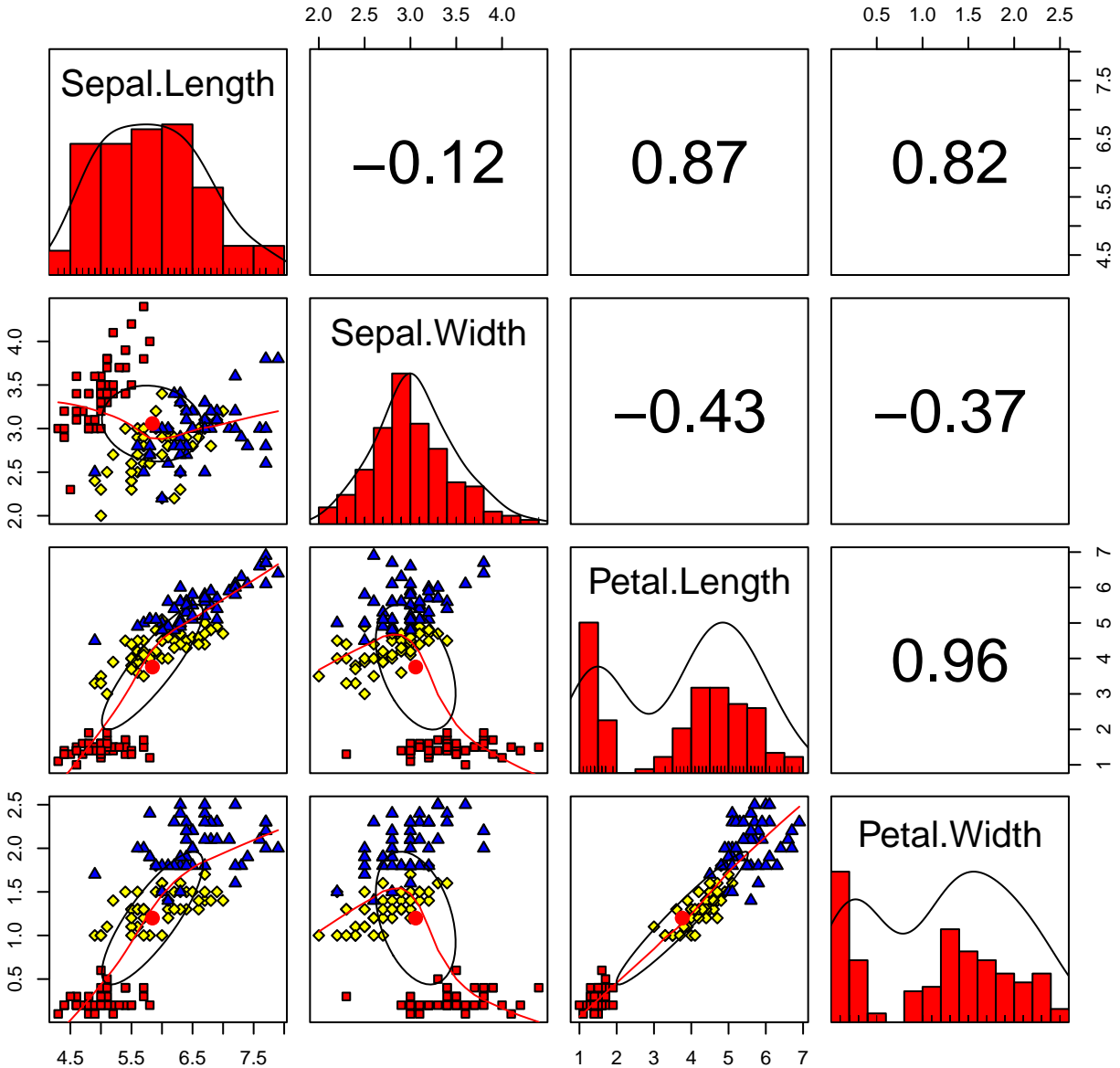

help("pairs.panels")

Fisher Iris data by Species

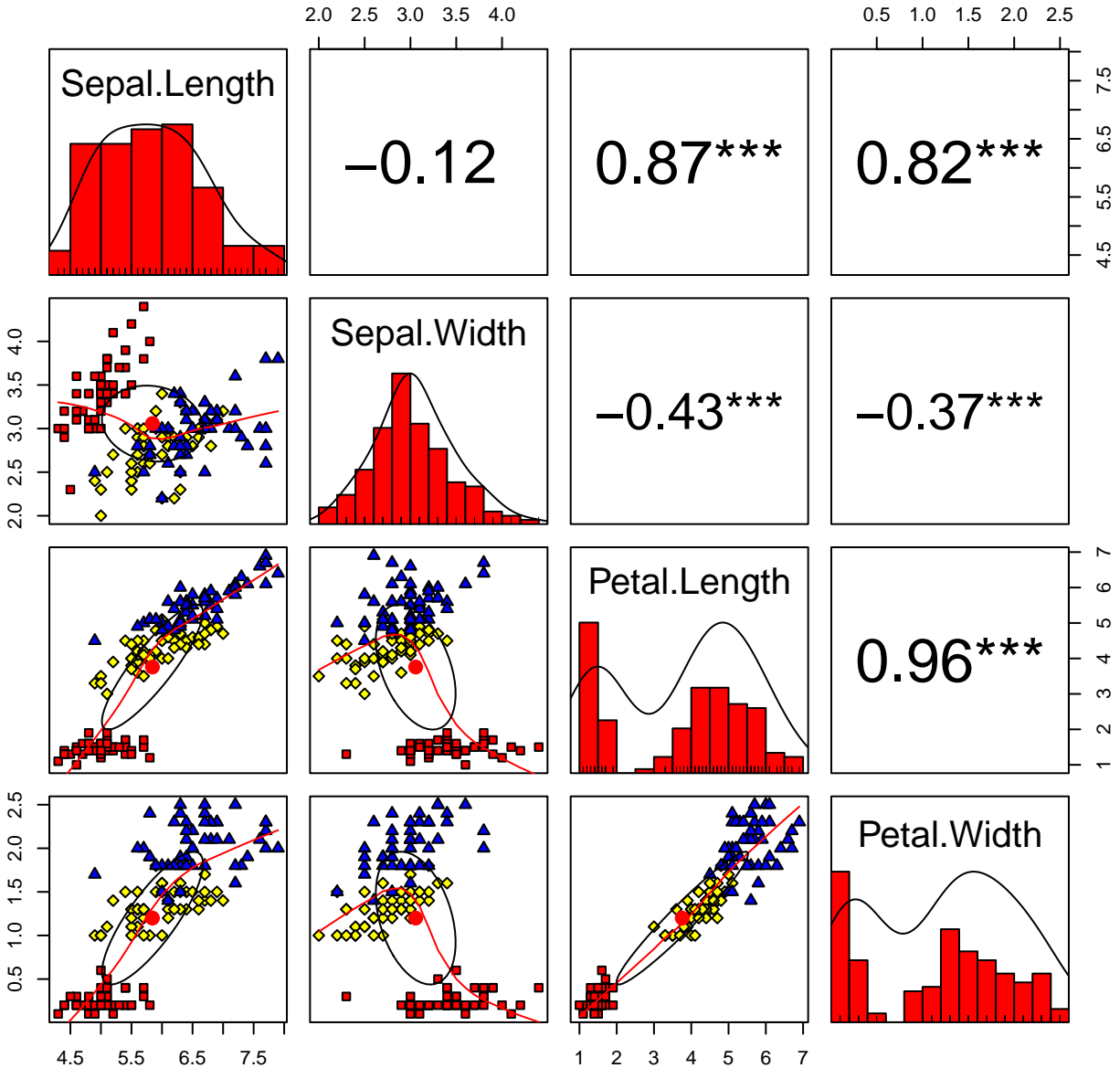

help("pairs:panels")

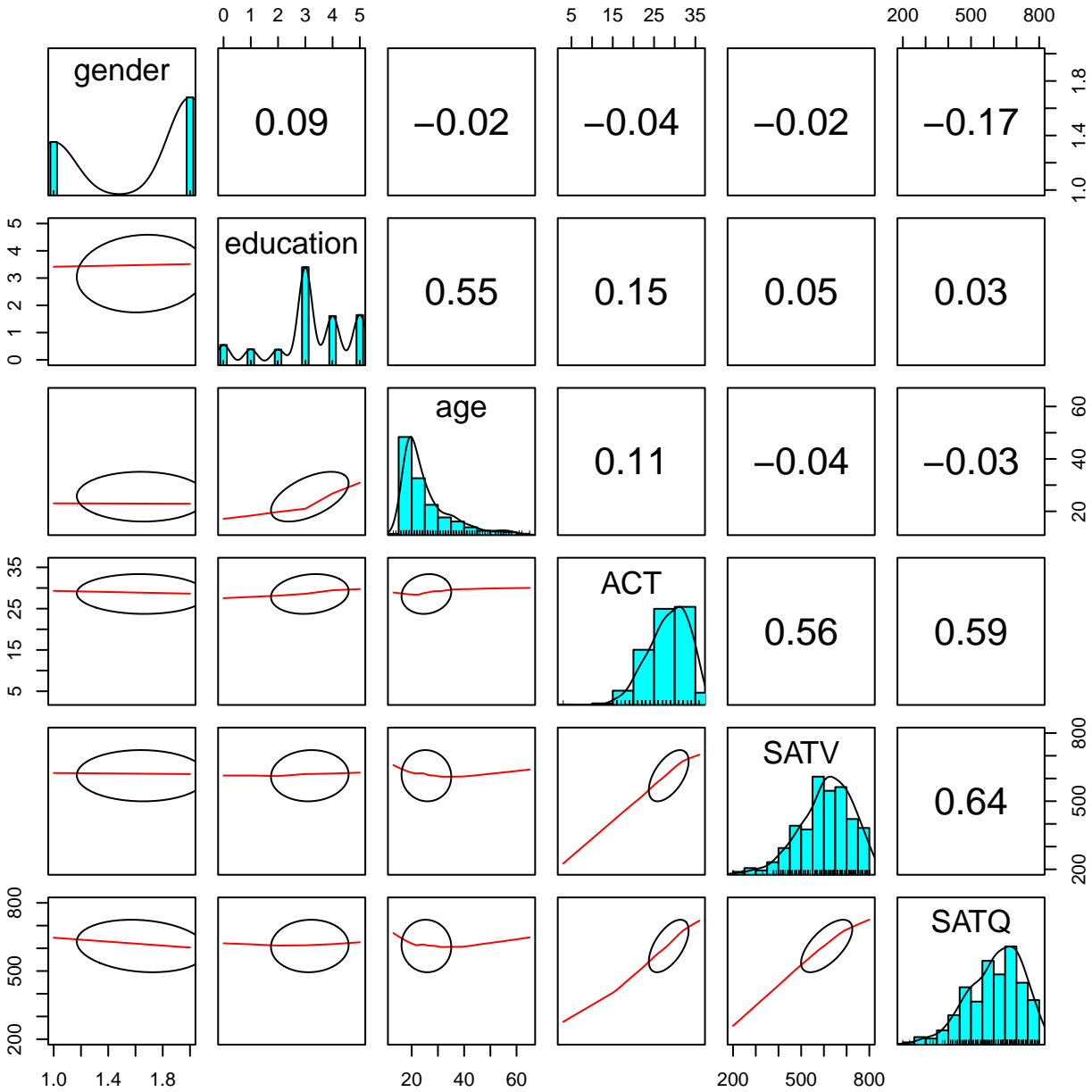

help("pairs.panels")

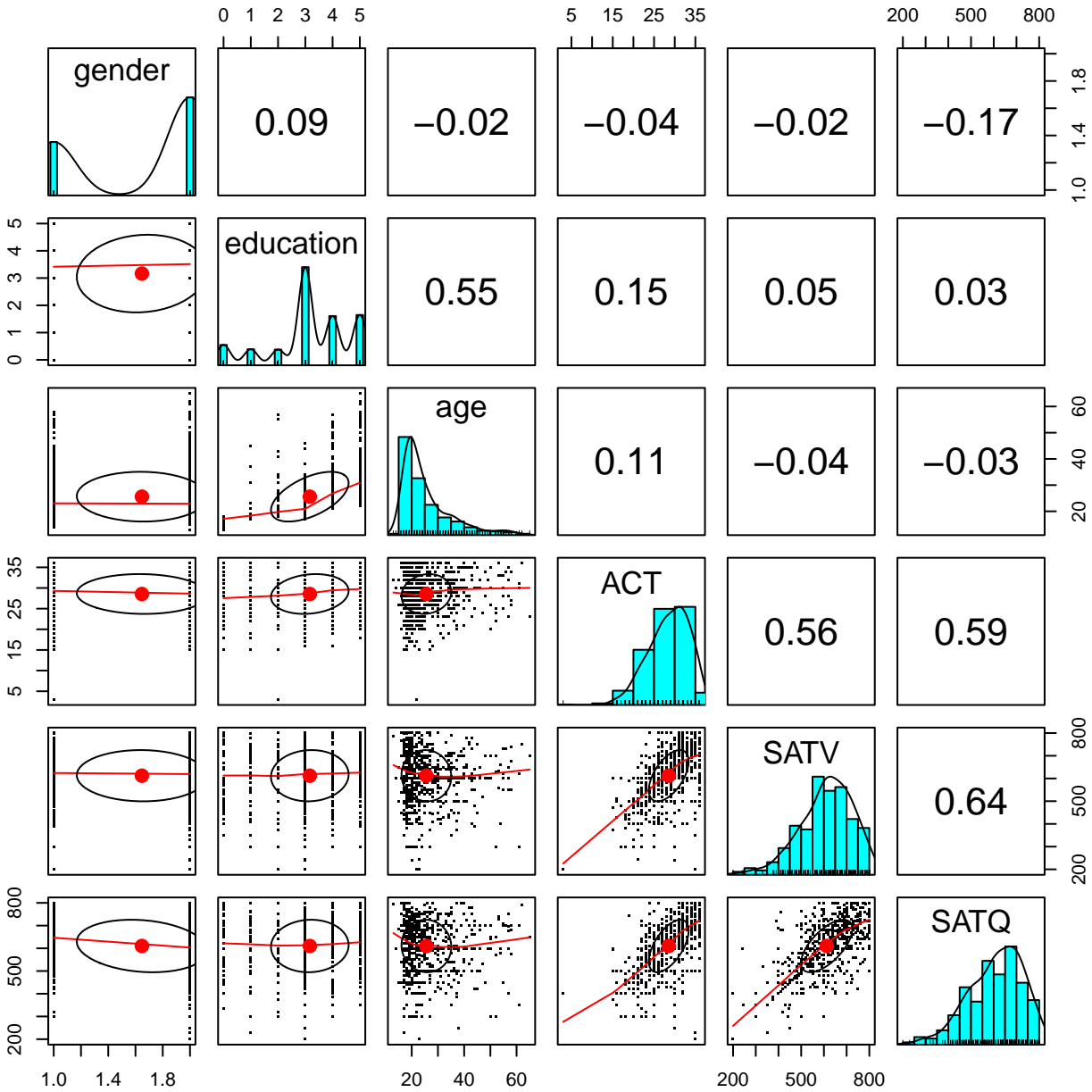

help("pairs.panels")

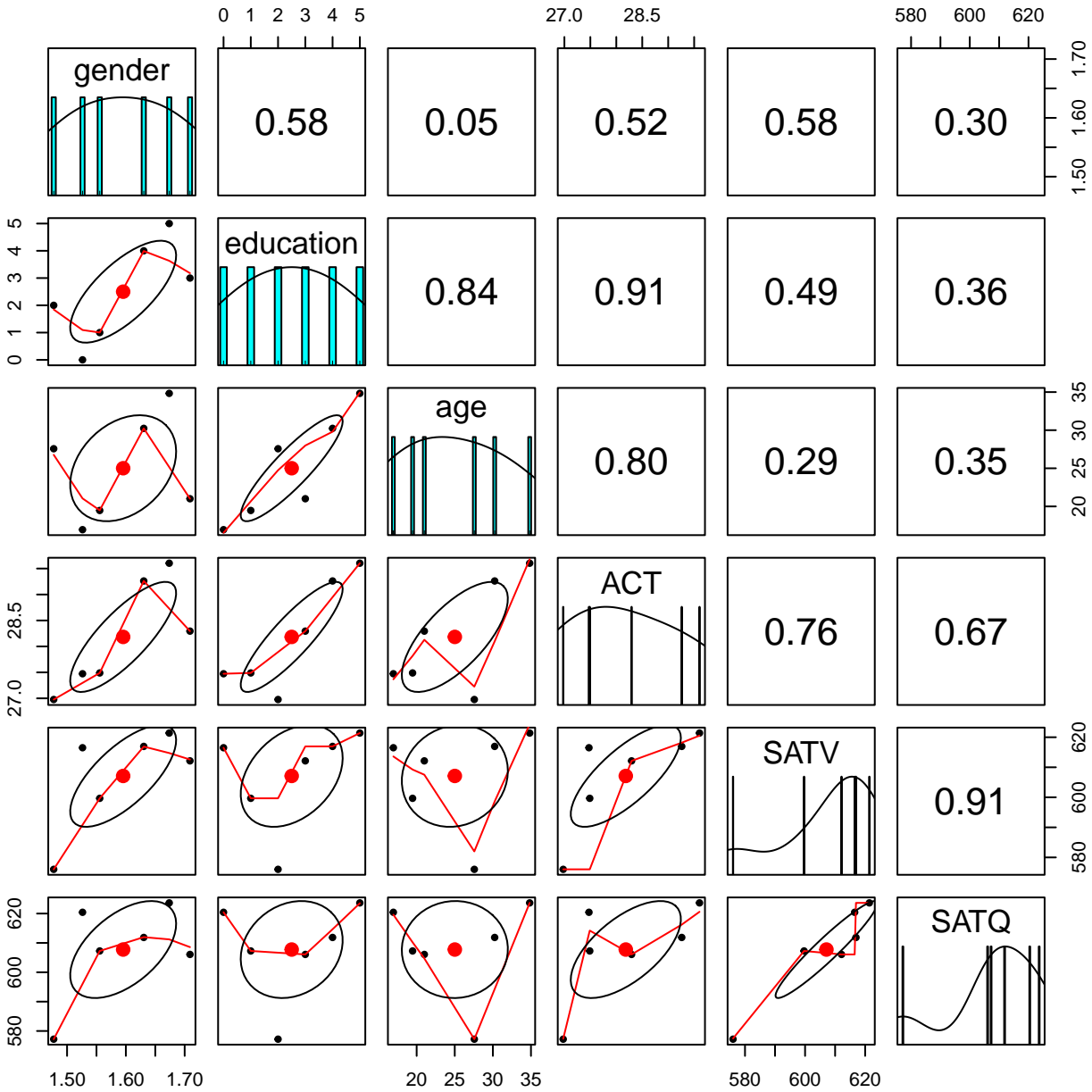

help("pairs.panels")

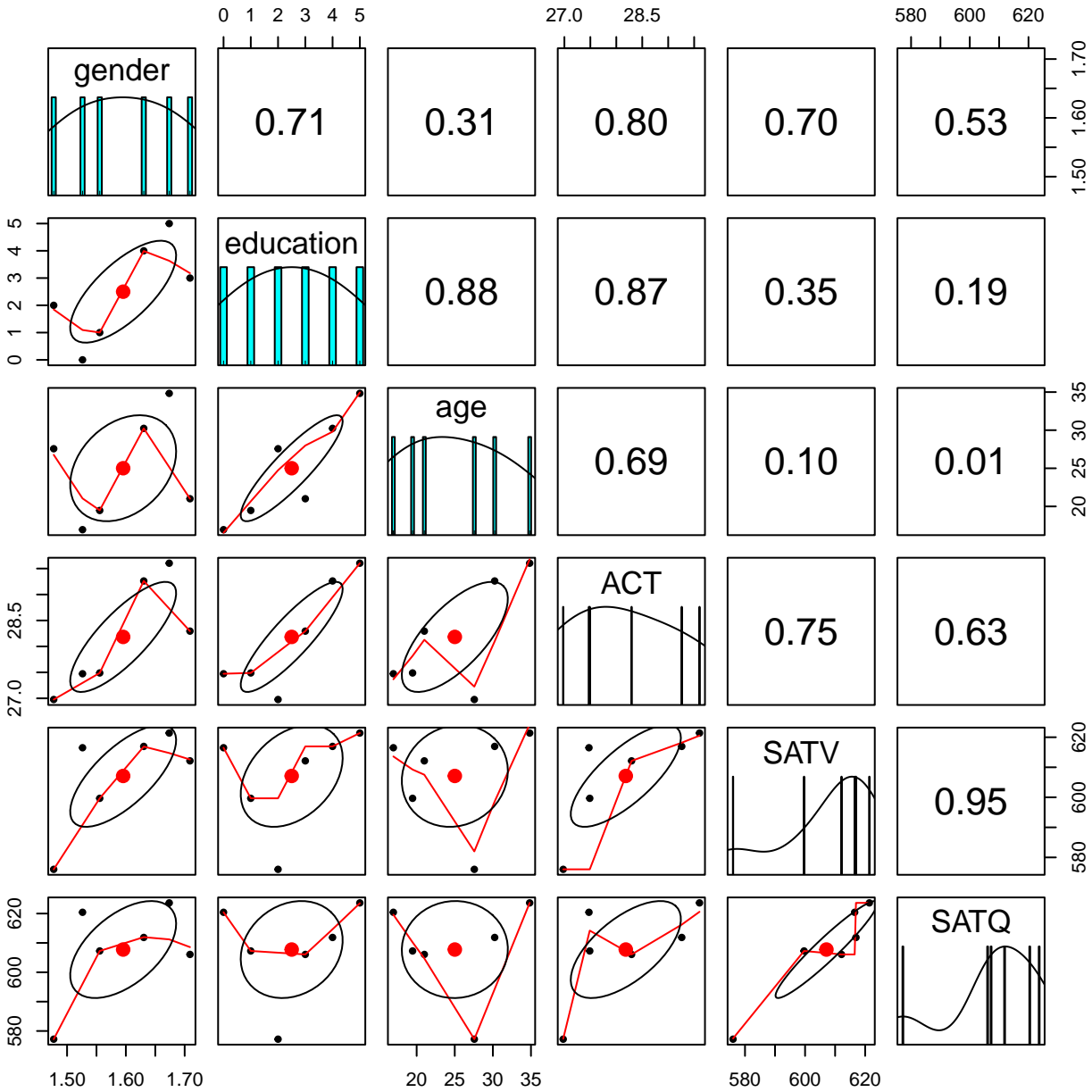

help("pairs.panels")

Factor Analysis

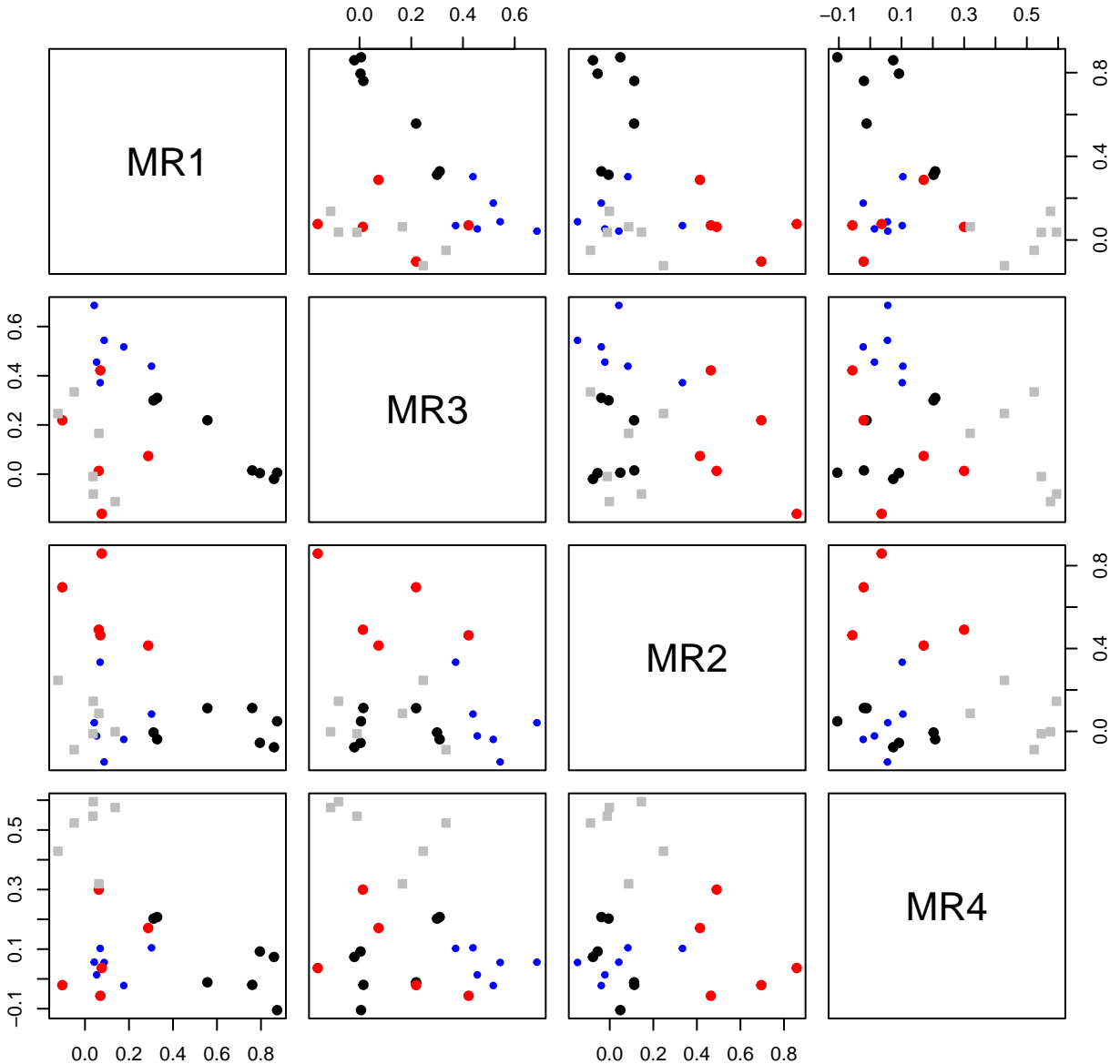

[help\("plot.psych"\)](#)

Plot of standardized residuals

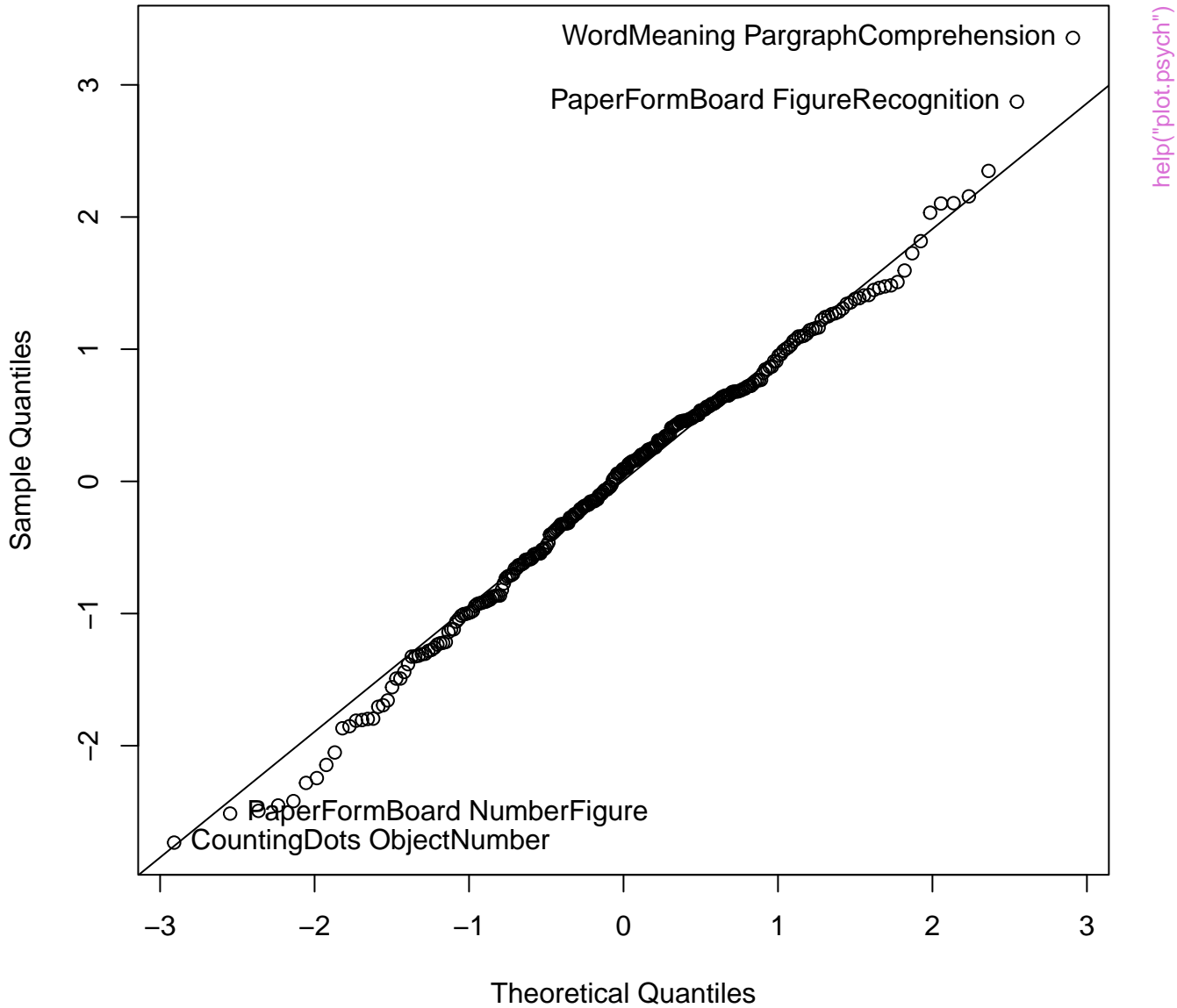

Residuals from a 4 factor solution

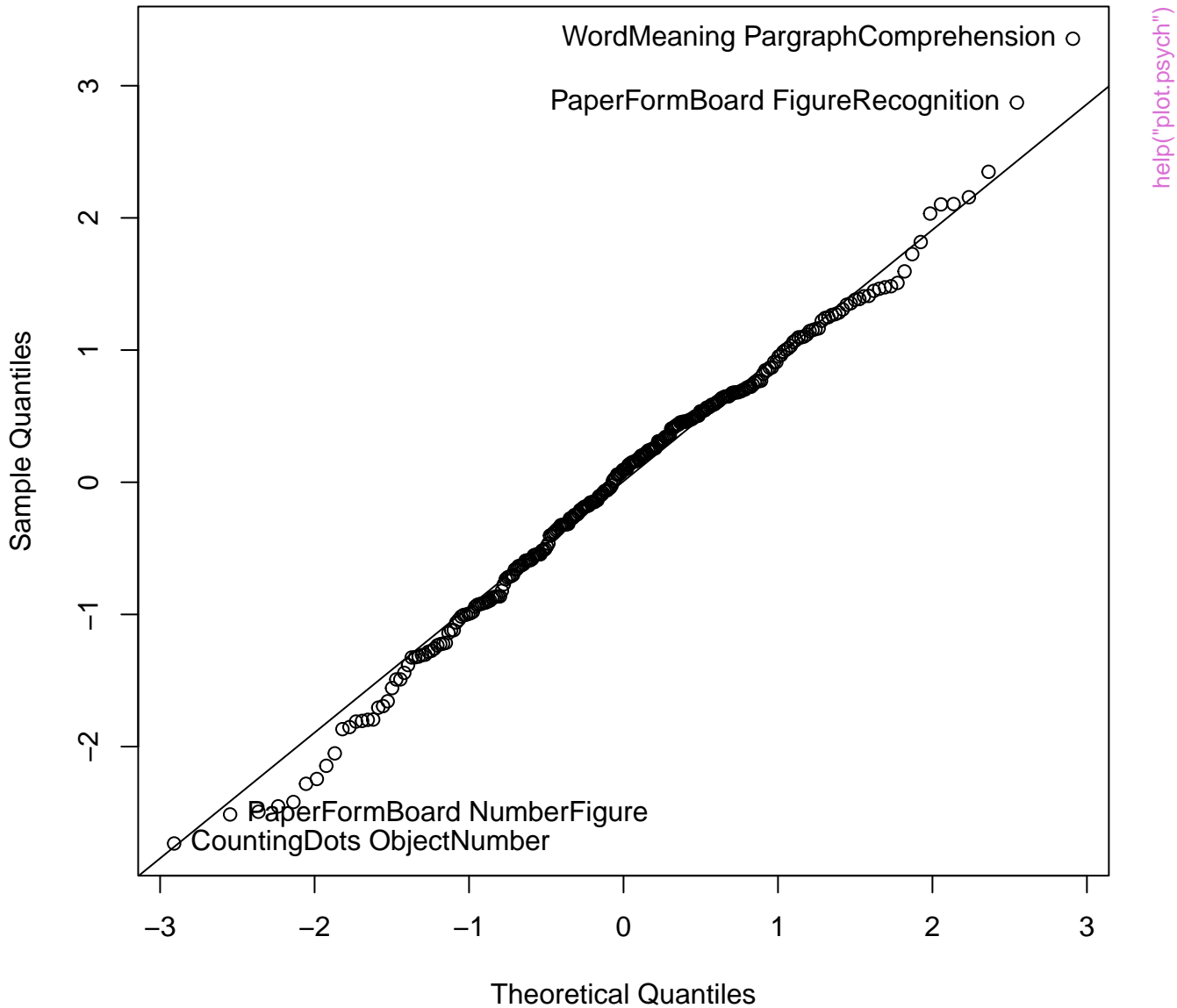

ICLUST

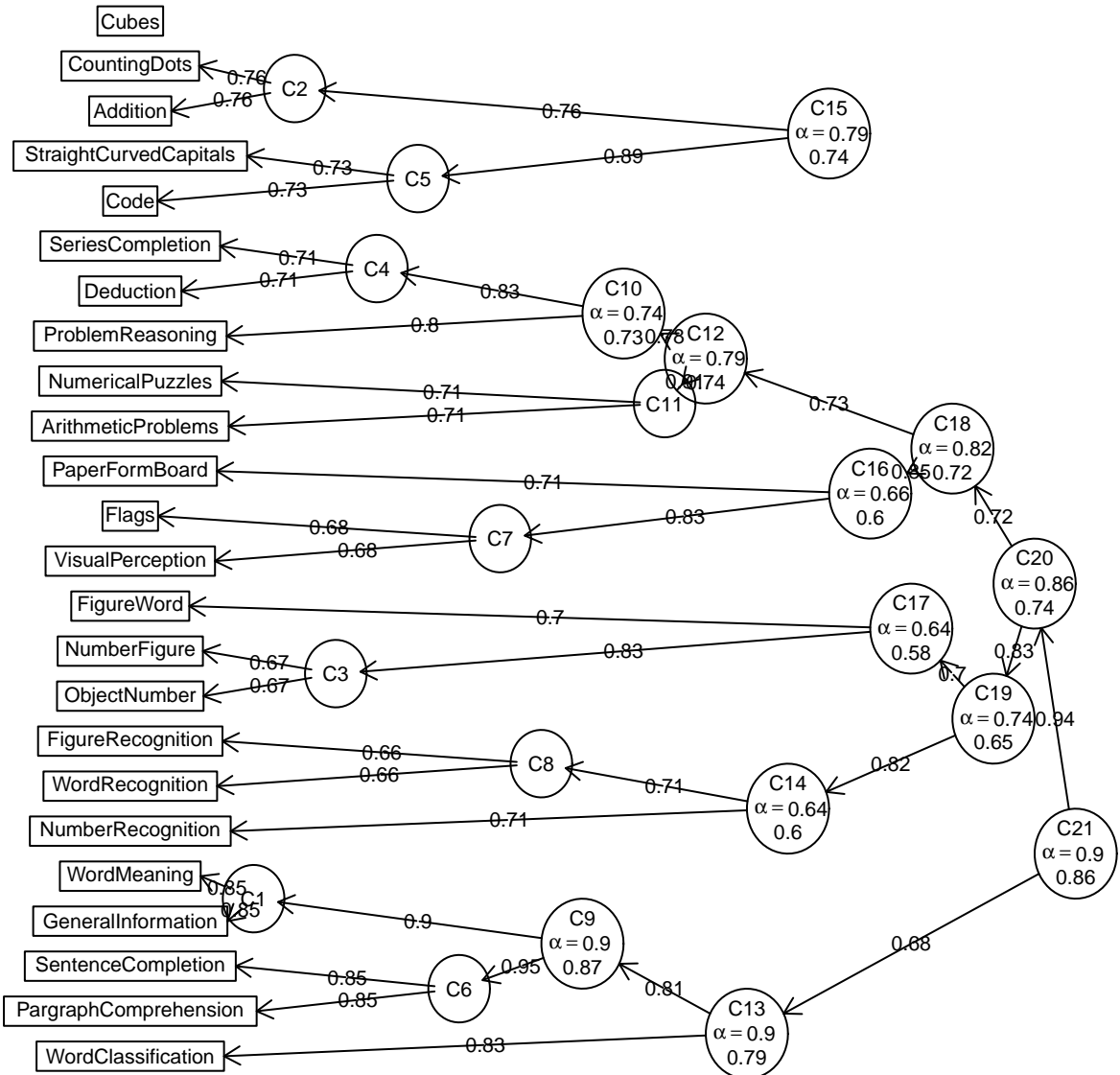

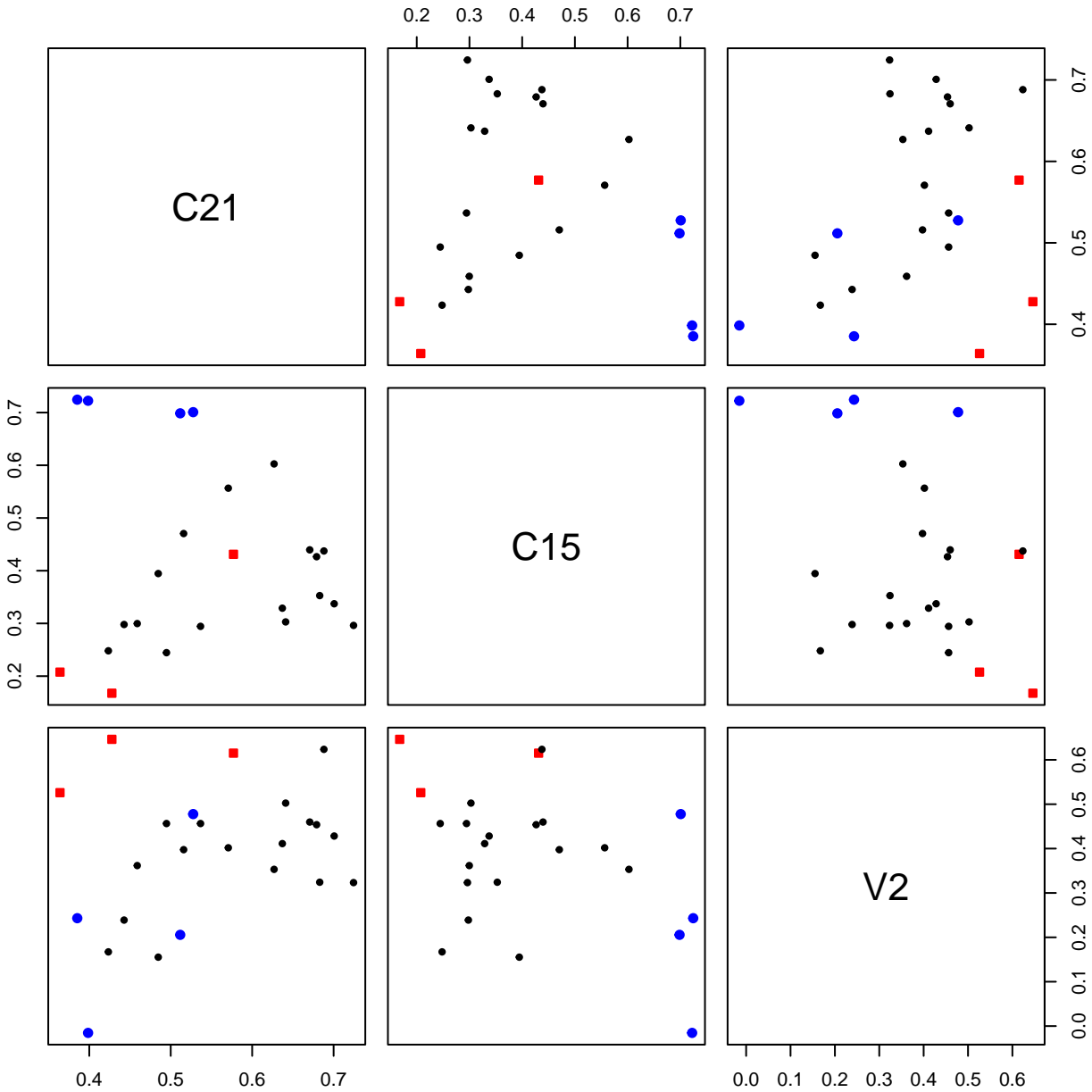

help("plot.psych")

Cluster plot

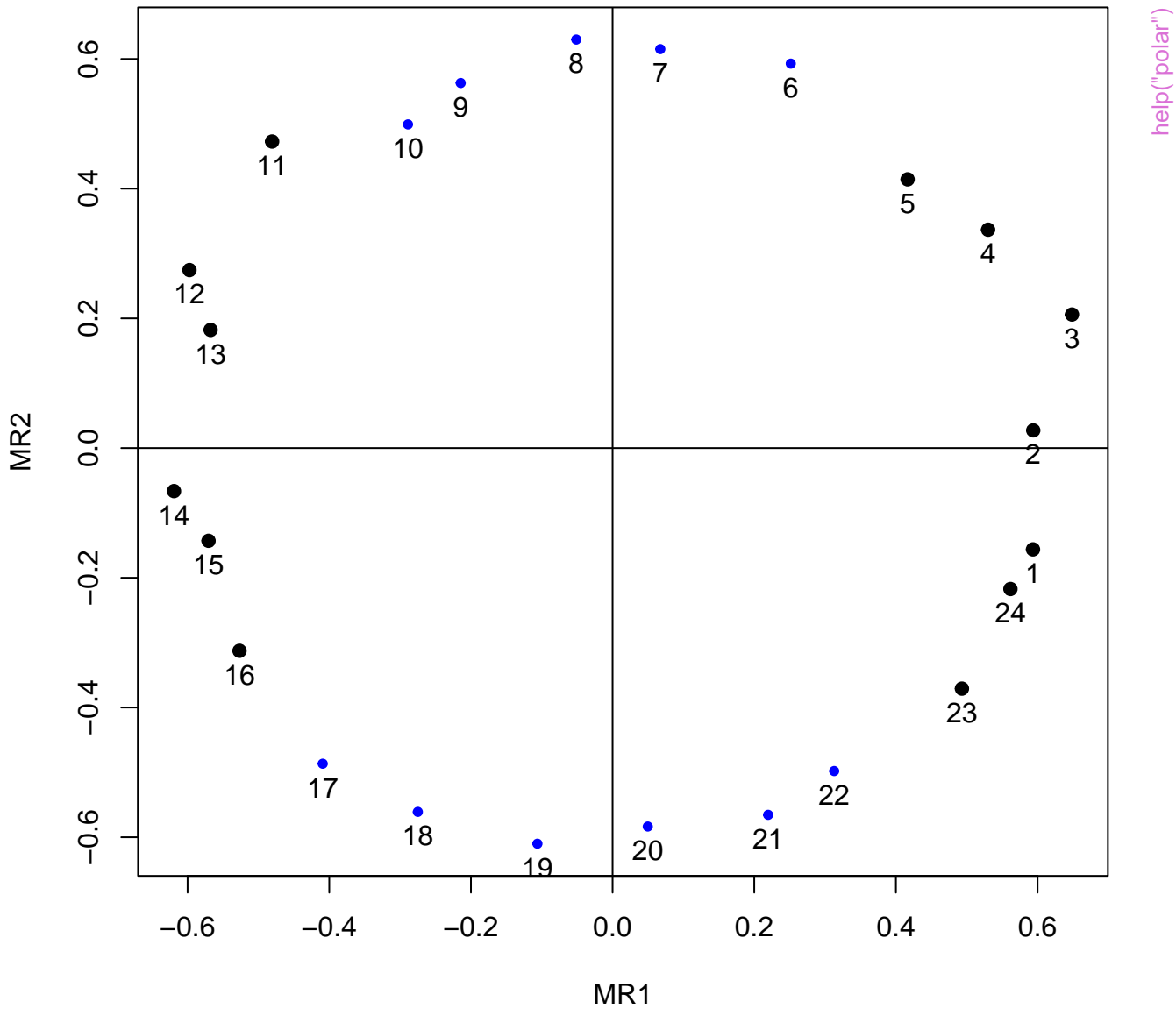

Biplot of the Harman.5 socio-economic variables

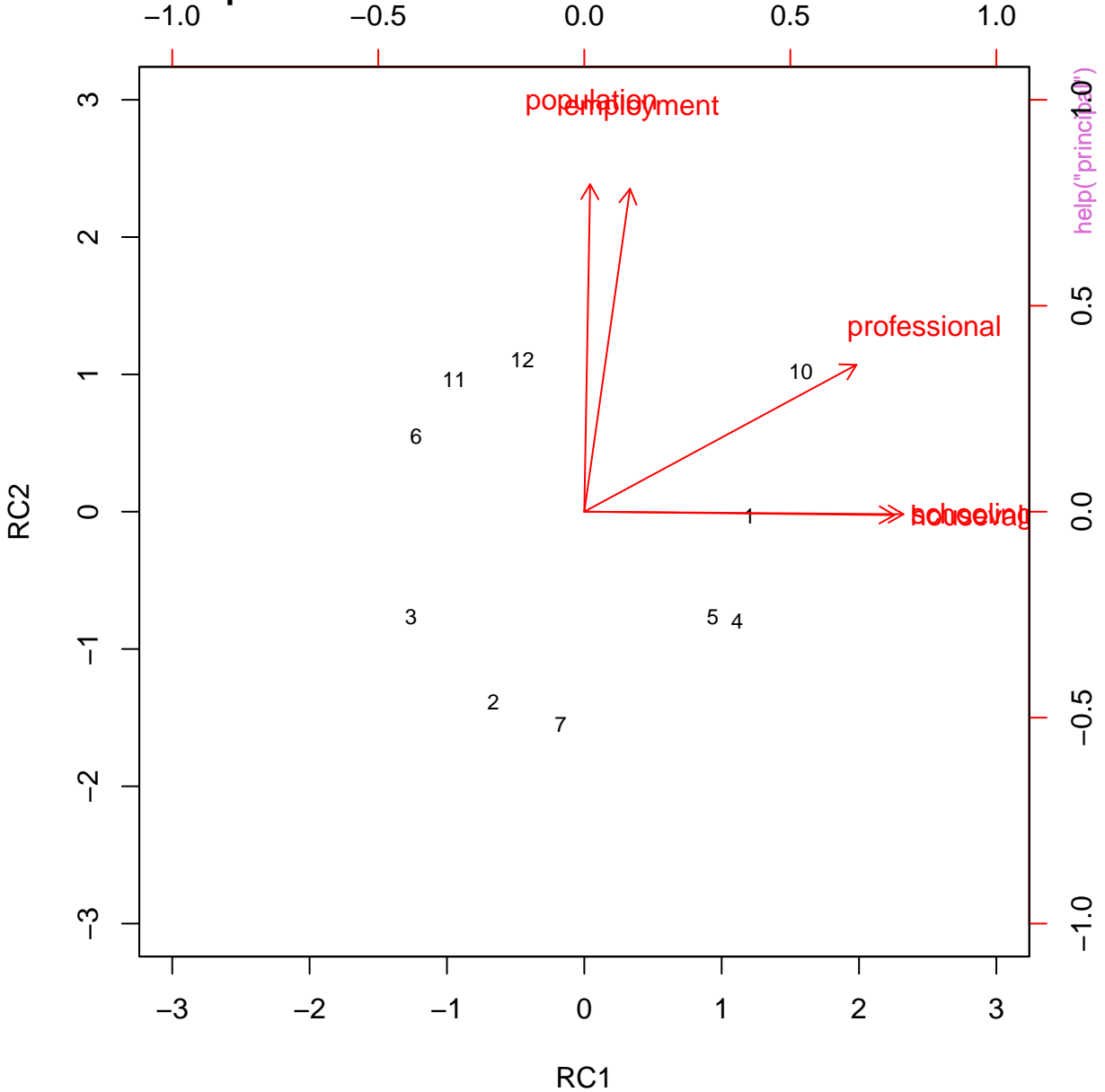

Split half distributions + ω_h α ω_t + unidim

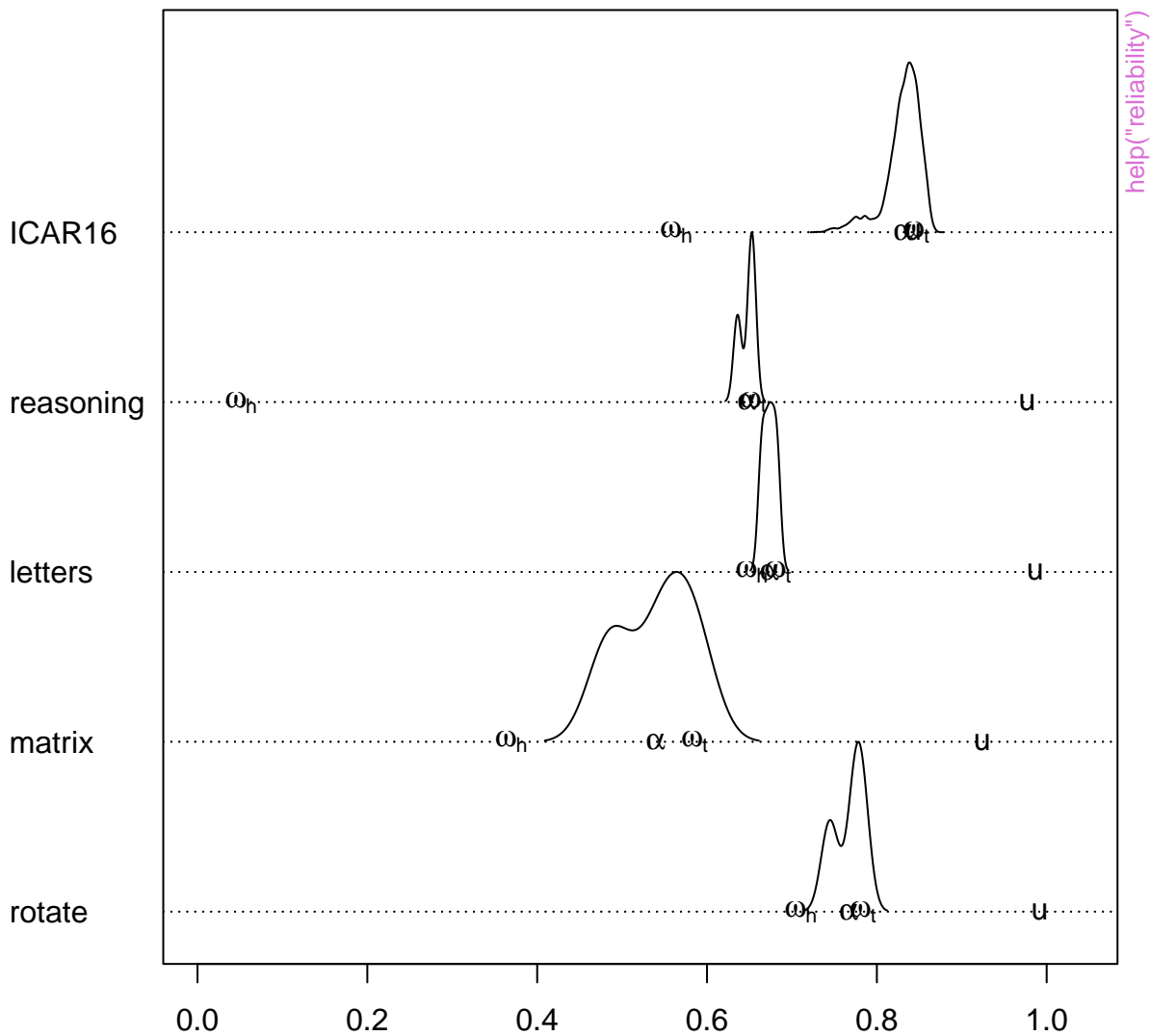

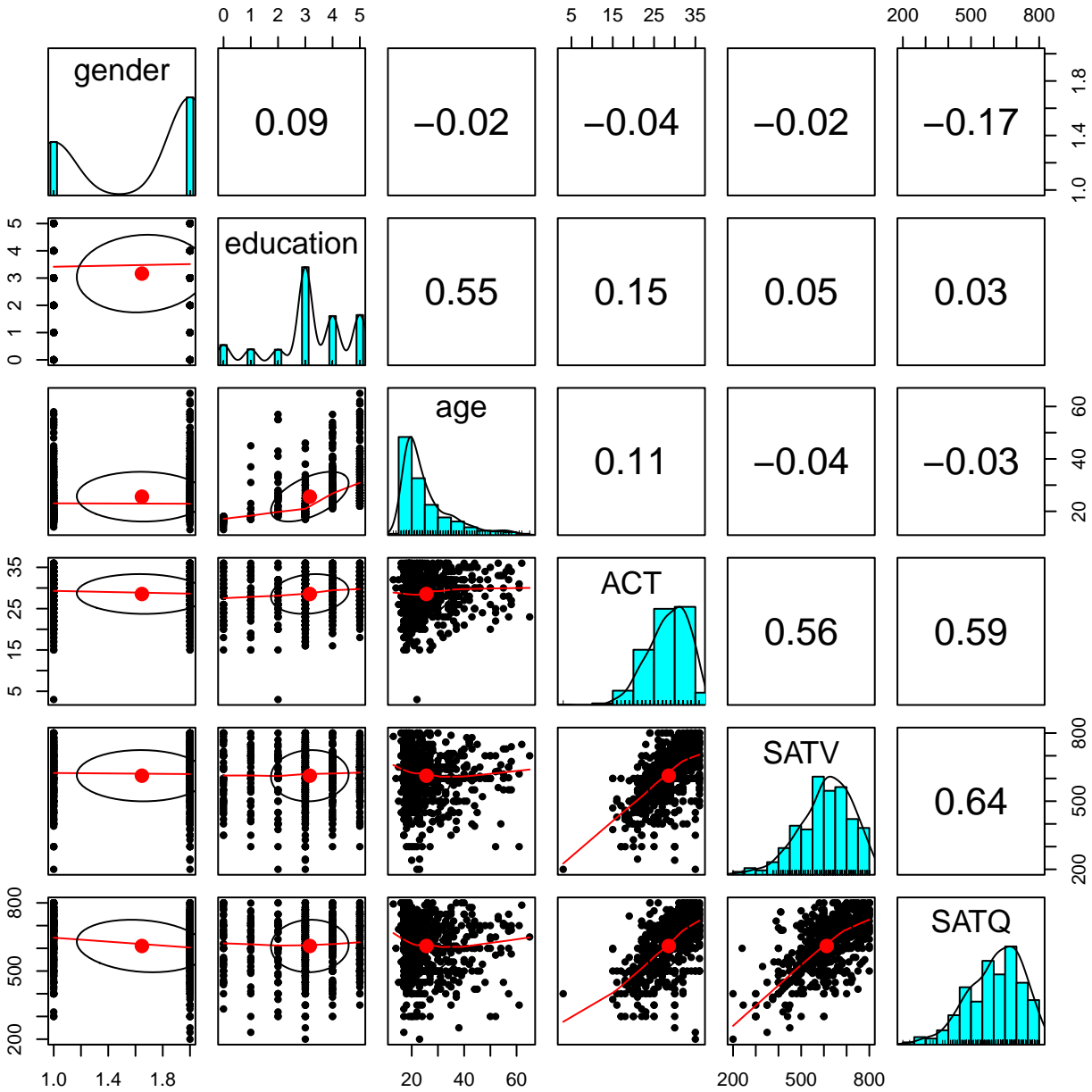

help("sat.act")

$r = 0.64$

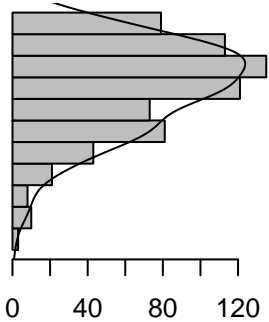
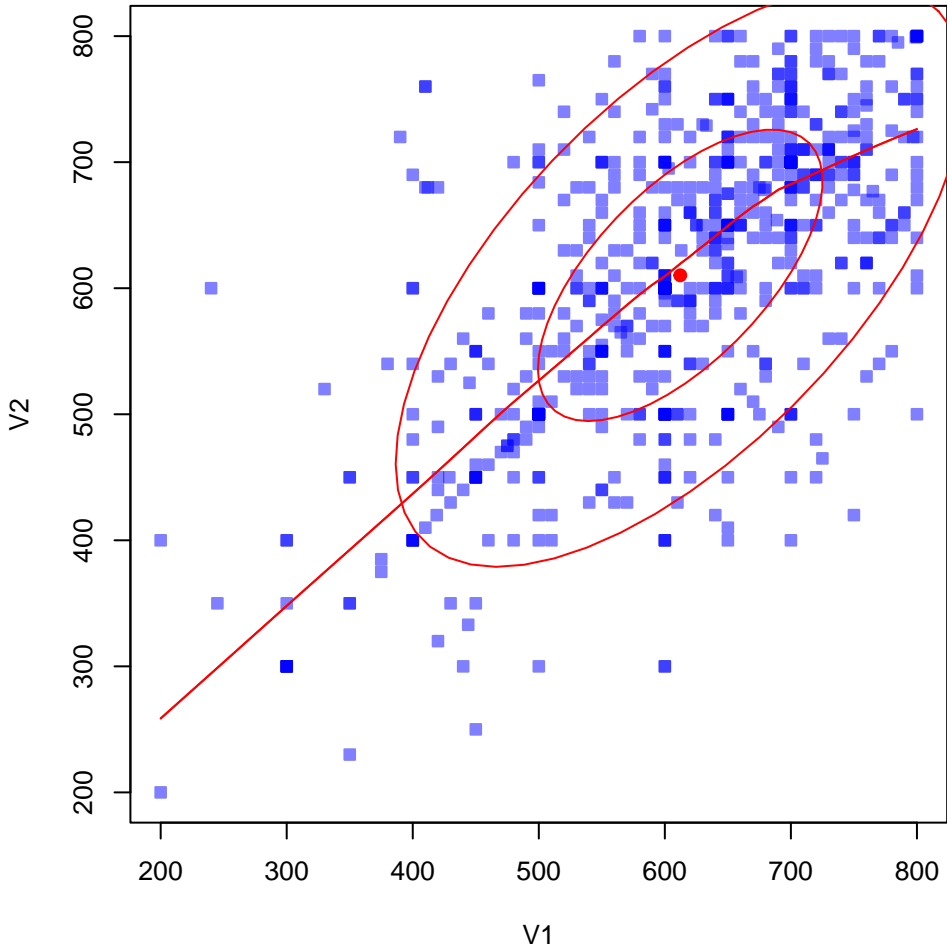
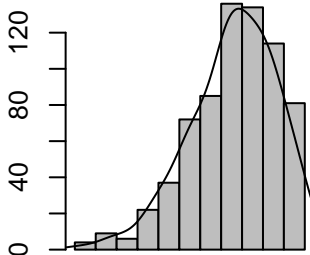

$r = 0.64$

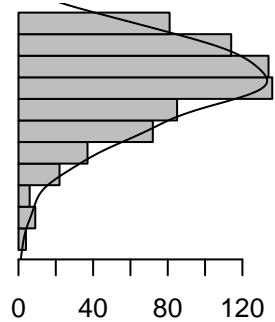
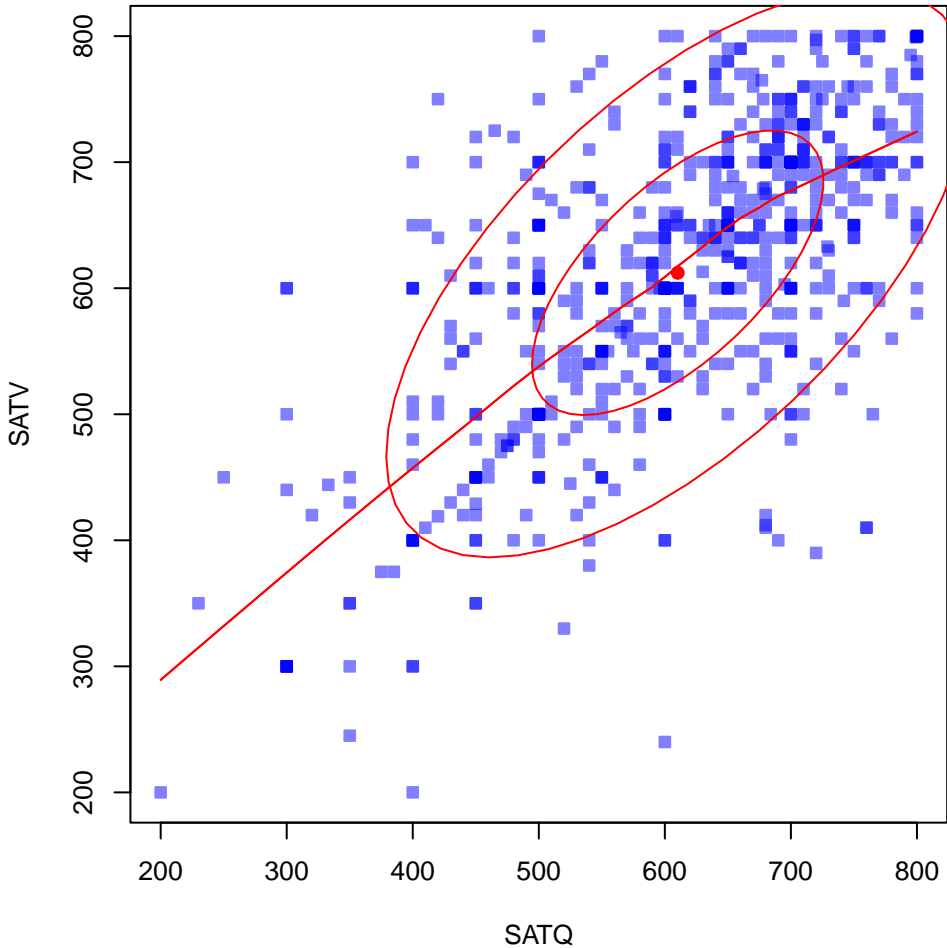
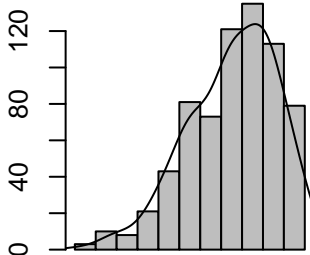

$r = 0.64$

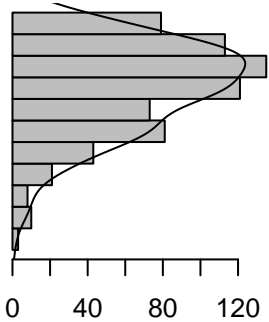
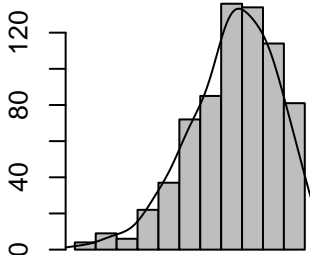
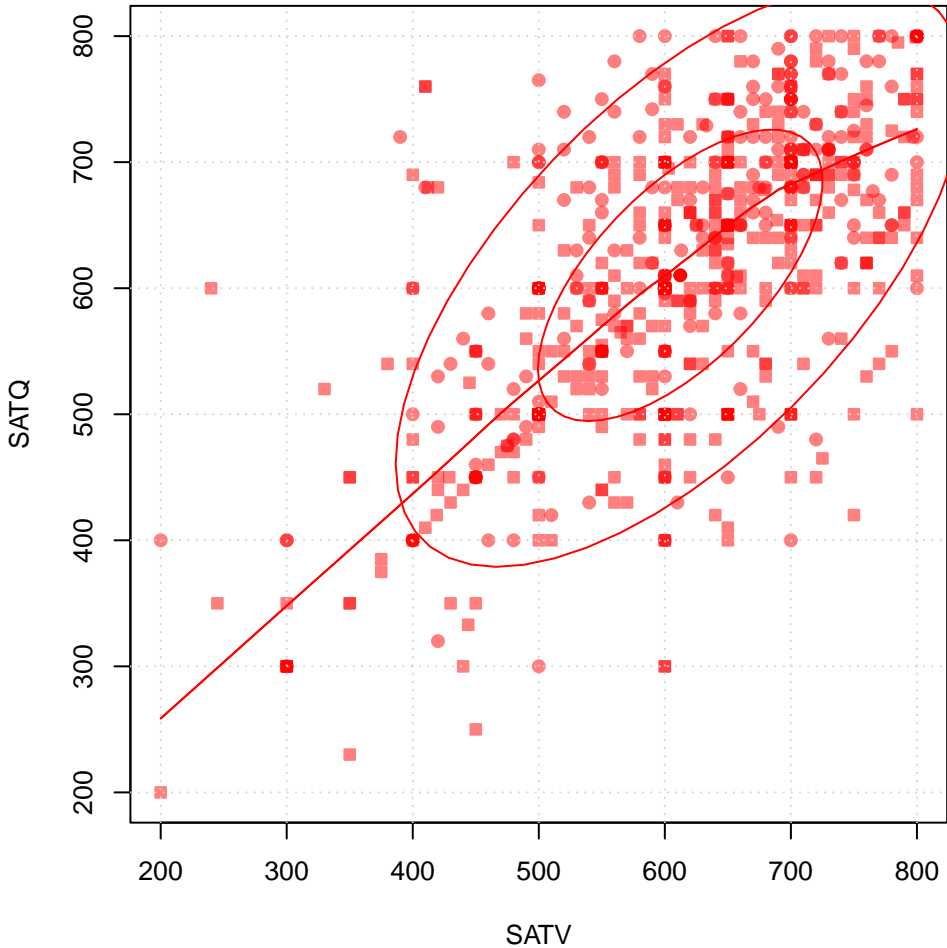

Scatter plot + density

Density

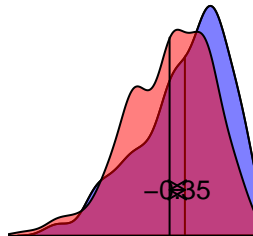

$r = 0.64$

$r \text{ wg} = 0.65$

help("scatter.hist")

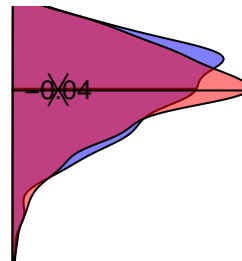
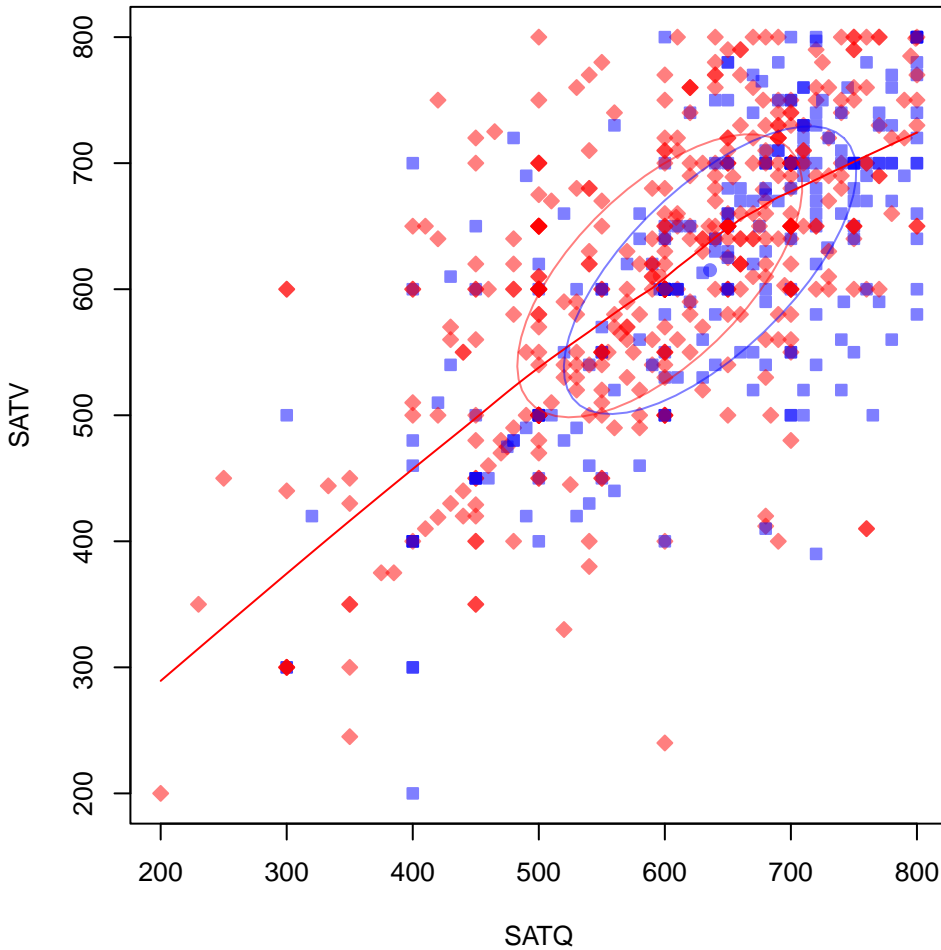

Density

Regression Models

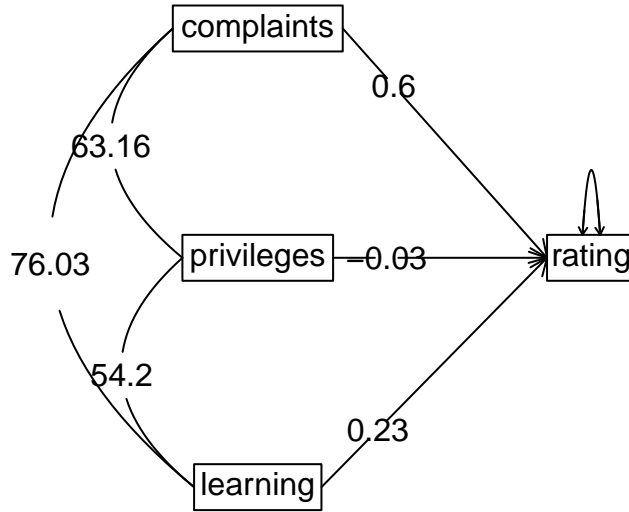

Regression Models



Regression Models

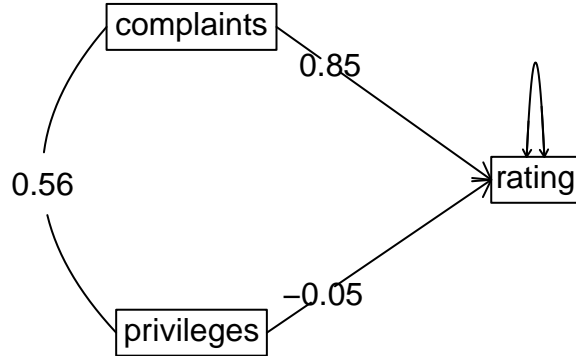

Regression Models

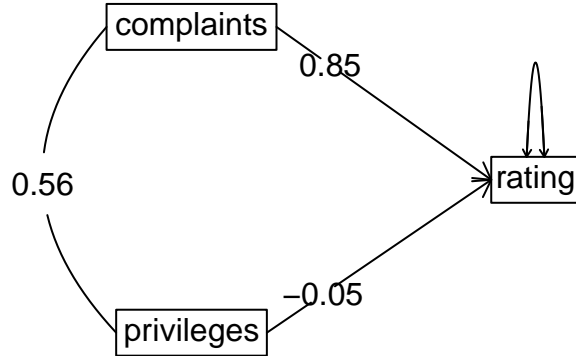

Regression Models

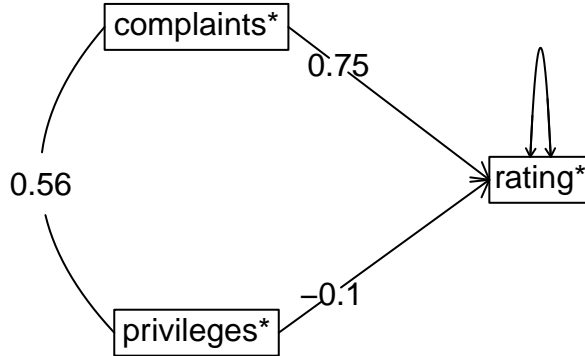

Regression Models

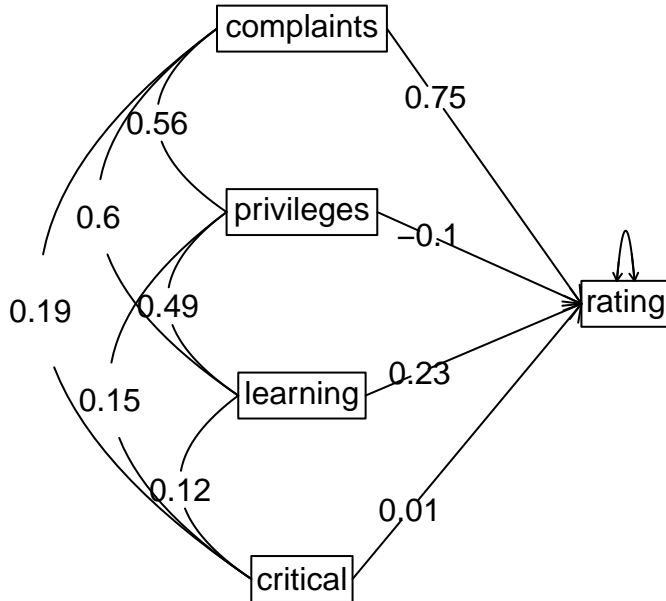

Regression Models

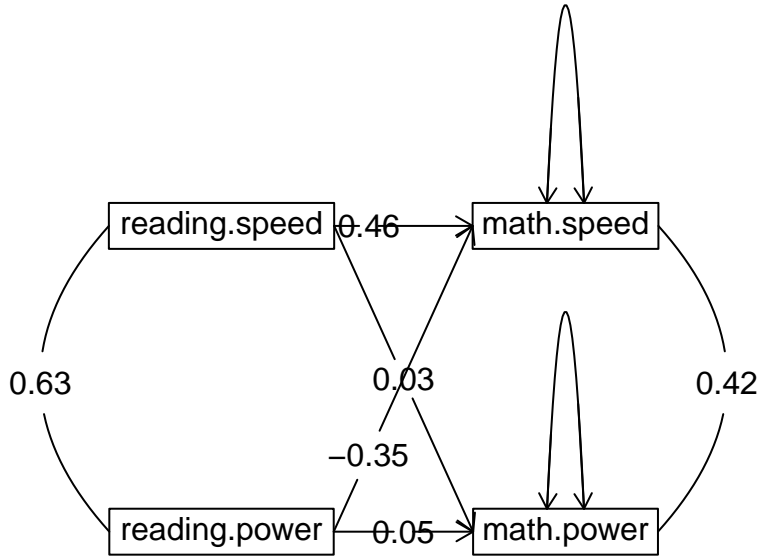

Regression Models

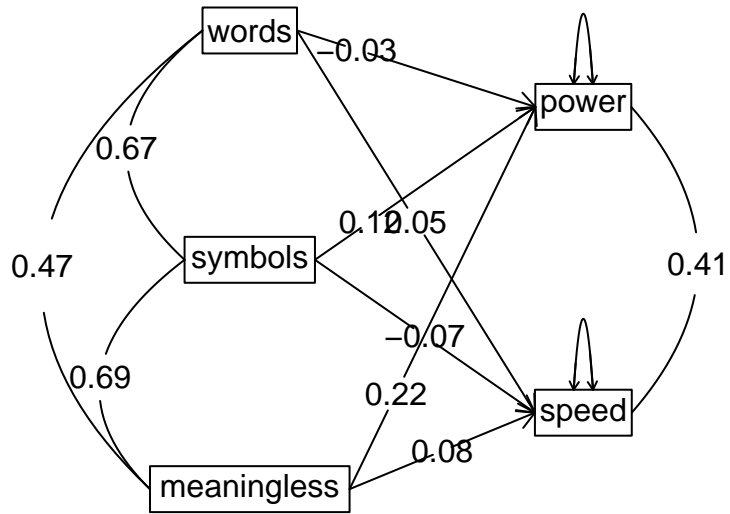

Regression Models

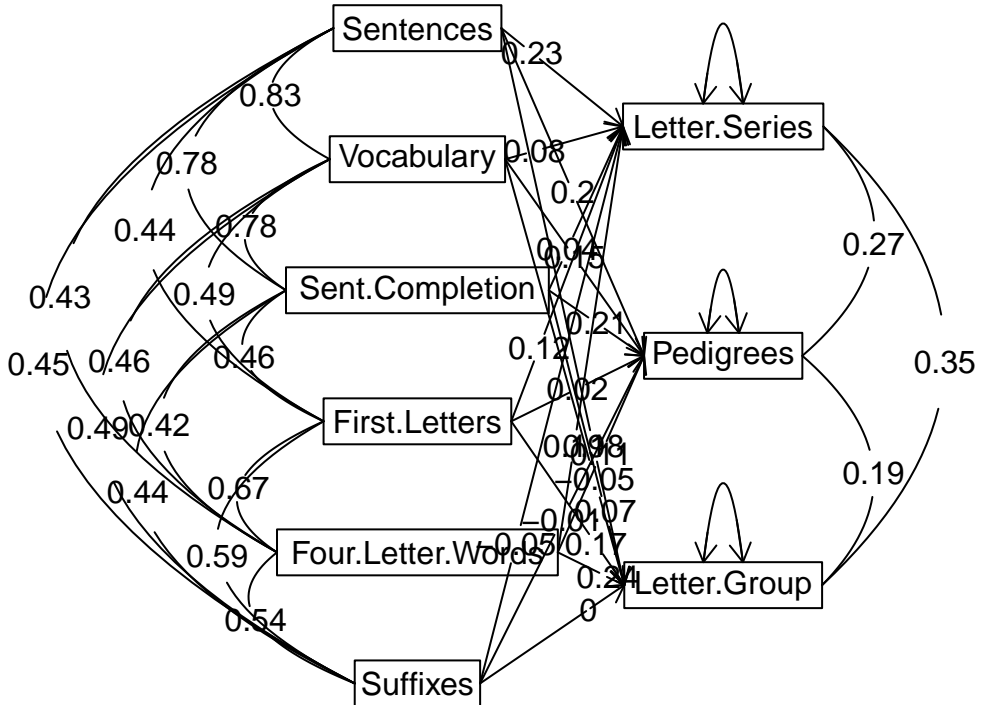

Regression Models

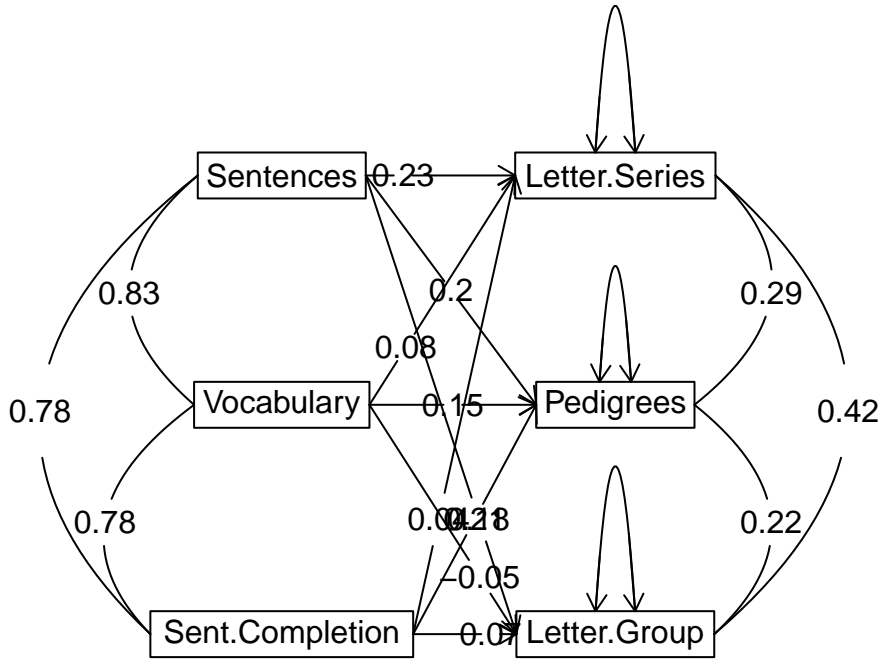

Regression Models

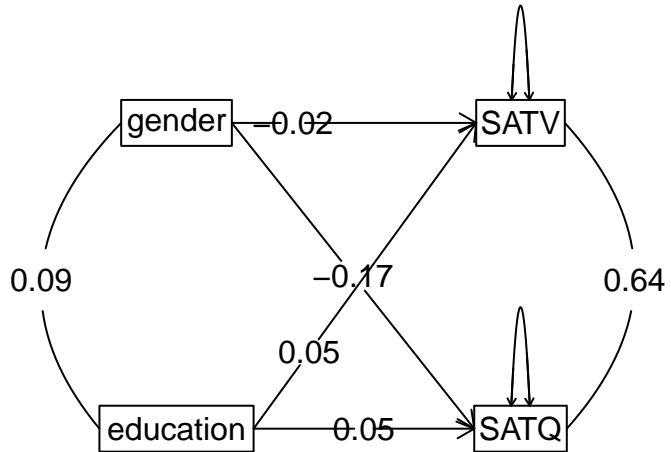

Regression Models

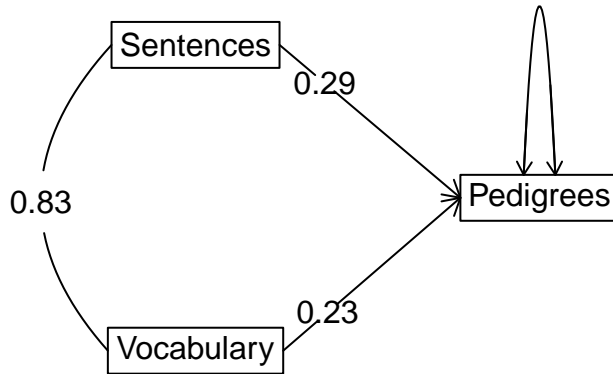

Regression Models

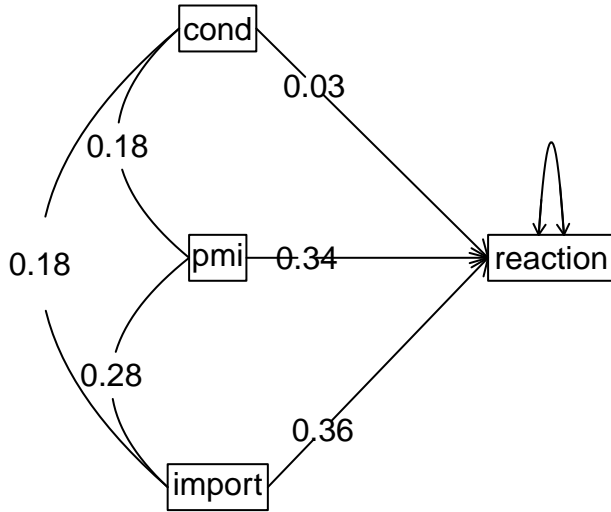

Partial out importance

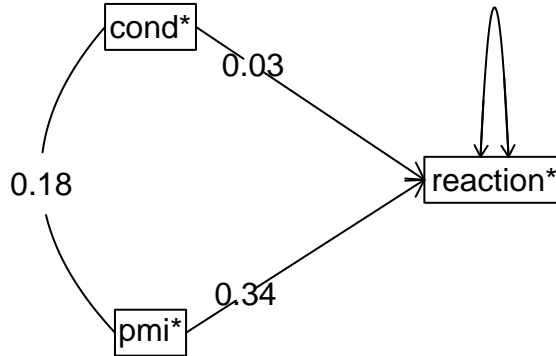

Partial out importance

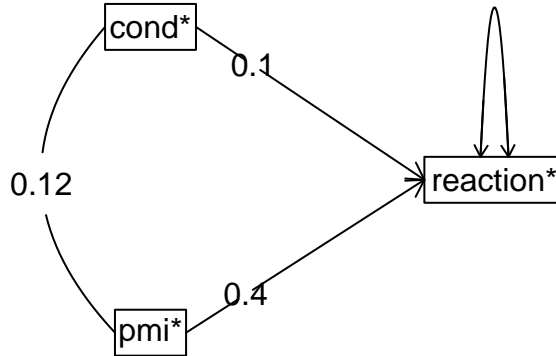

Regression Models

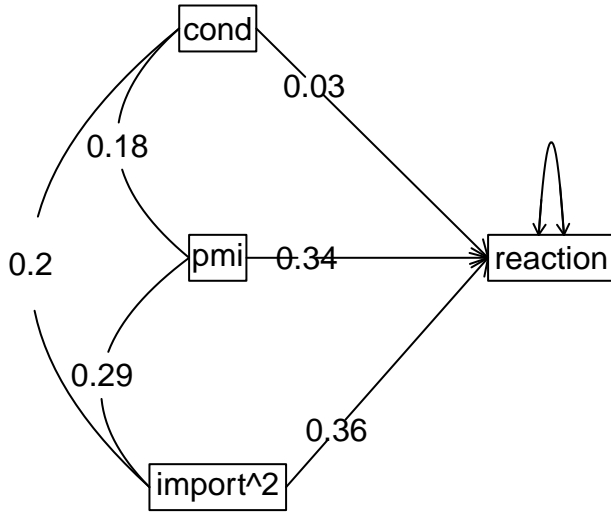

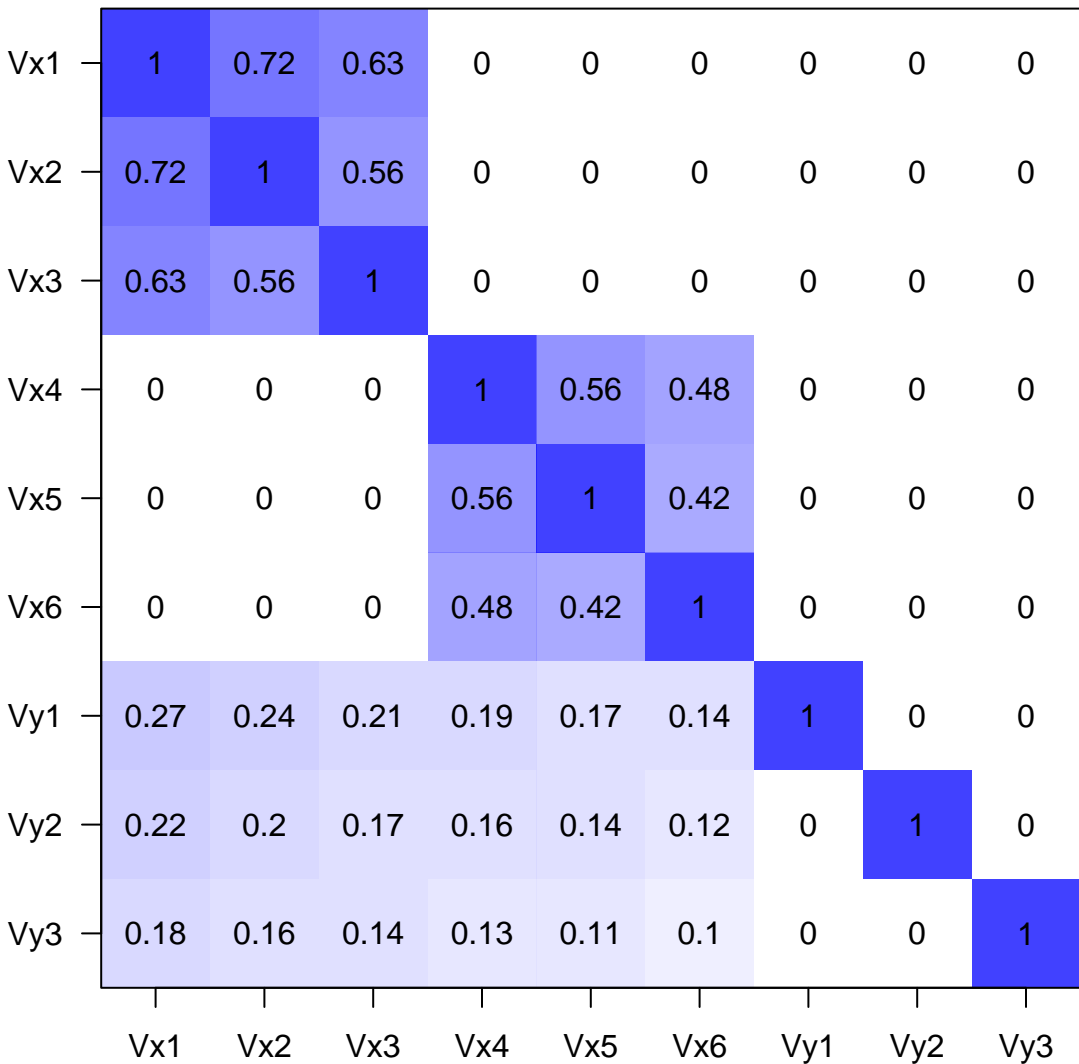

help("simr")

A simplex structure

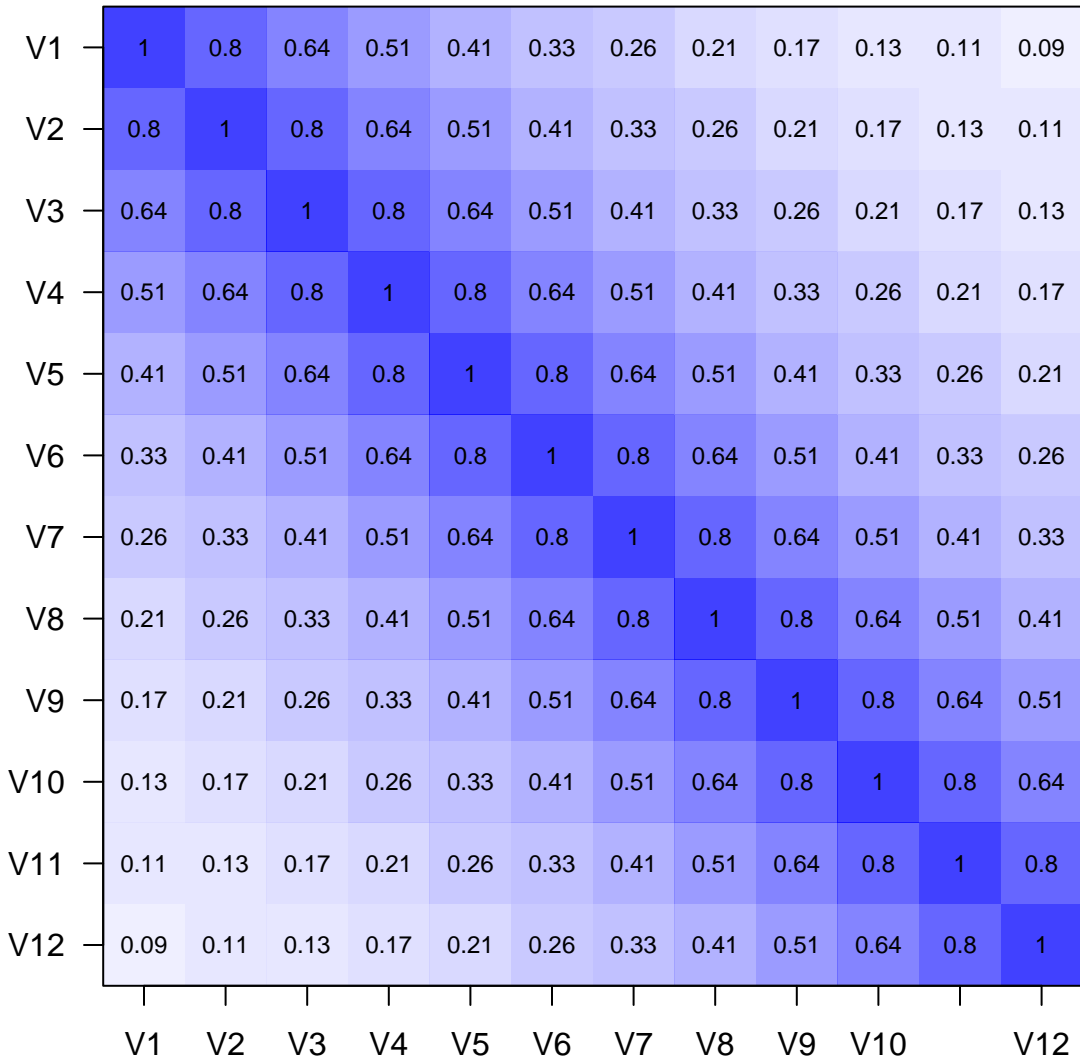

help("simr")

State Trait Auto Regressive Simplex

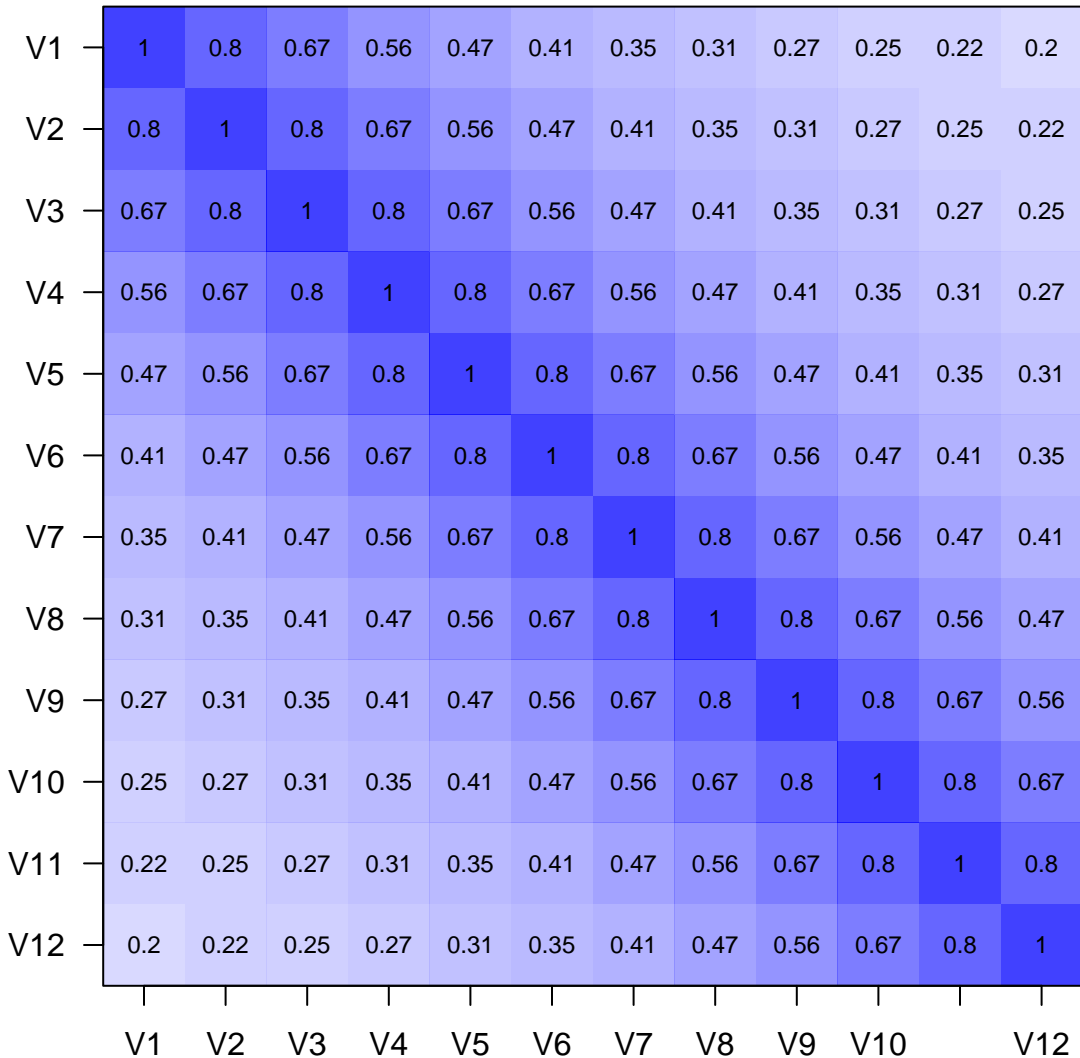

help("simr")

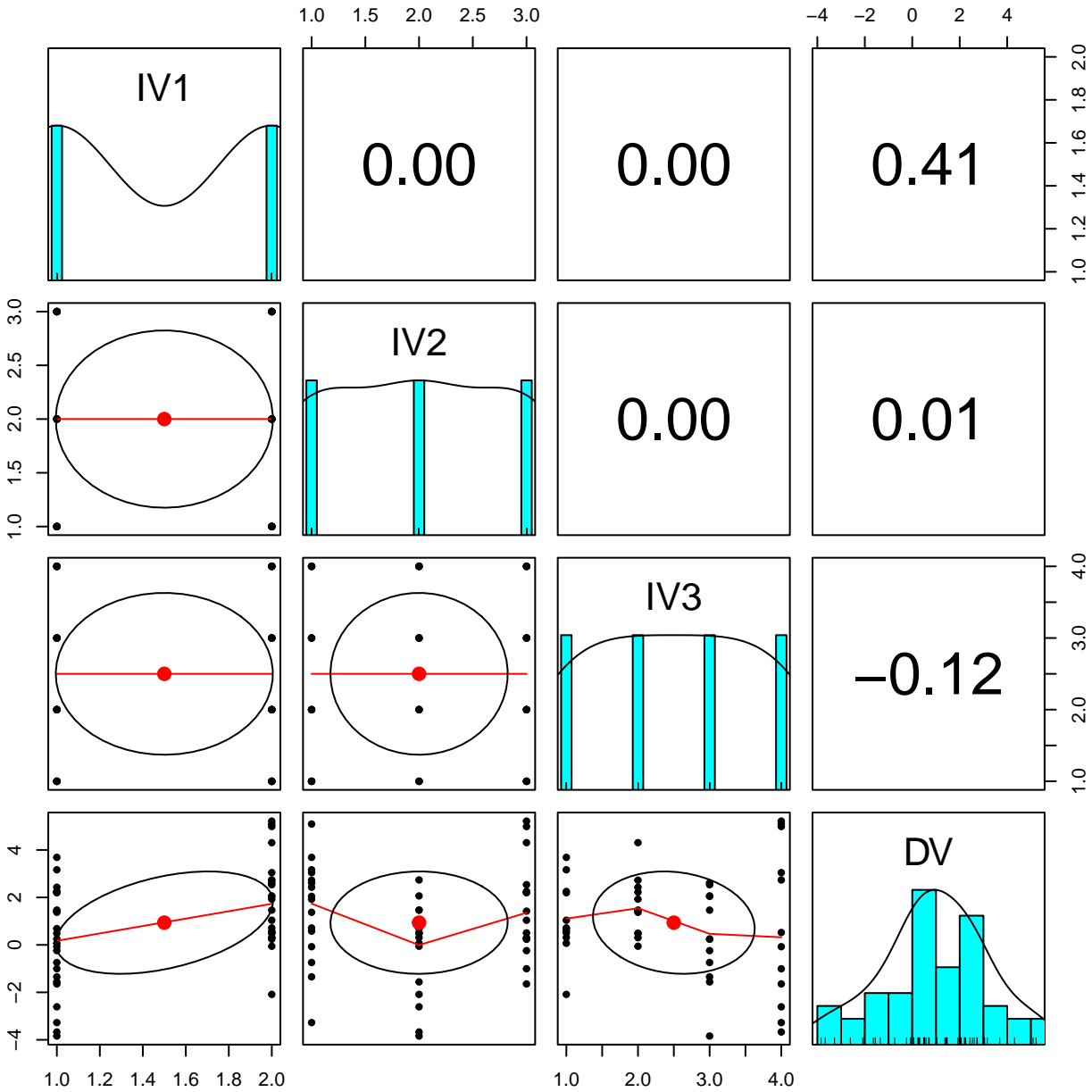

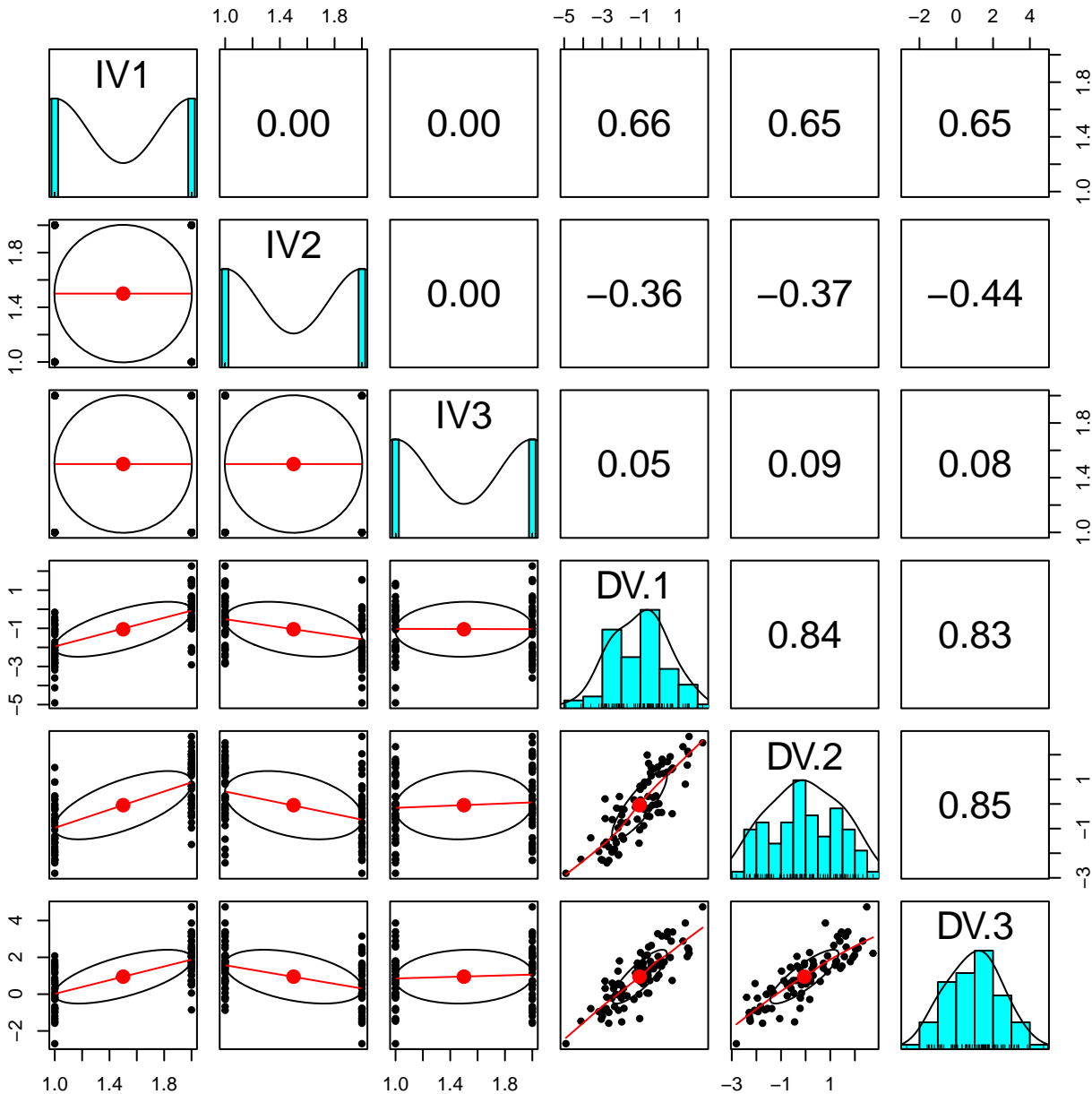

Item information from factor analysis

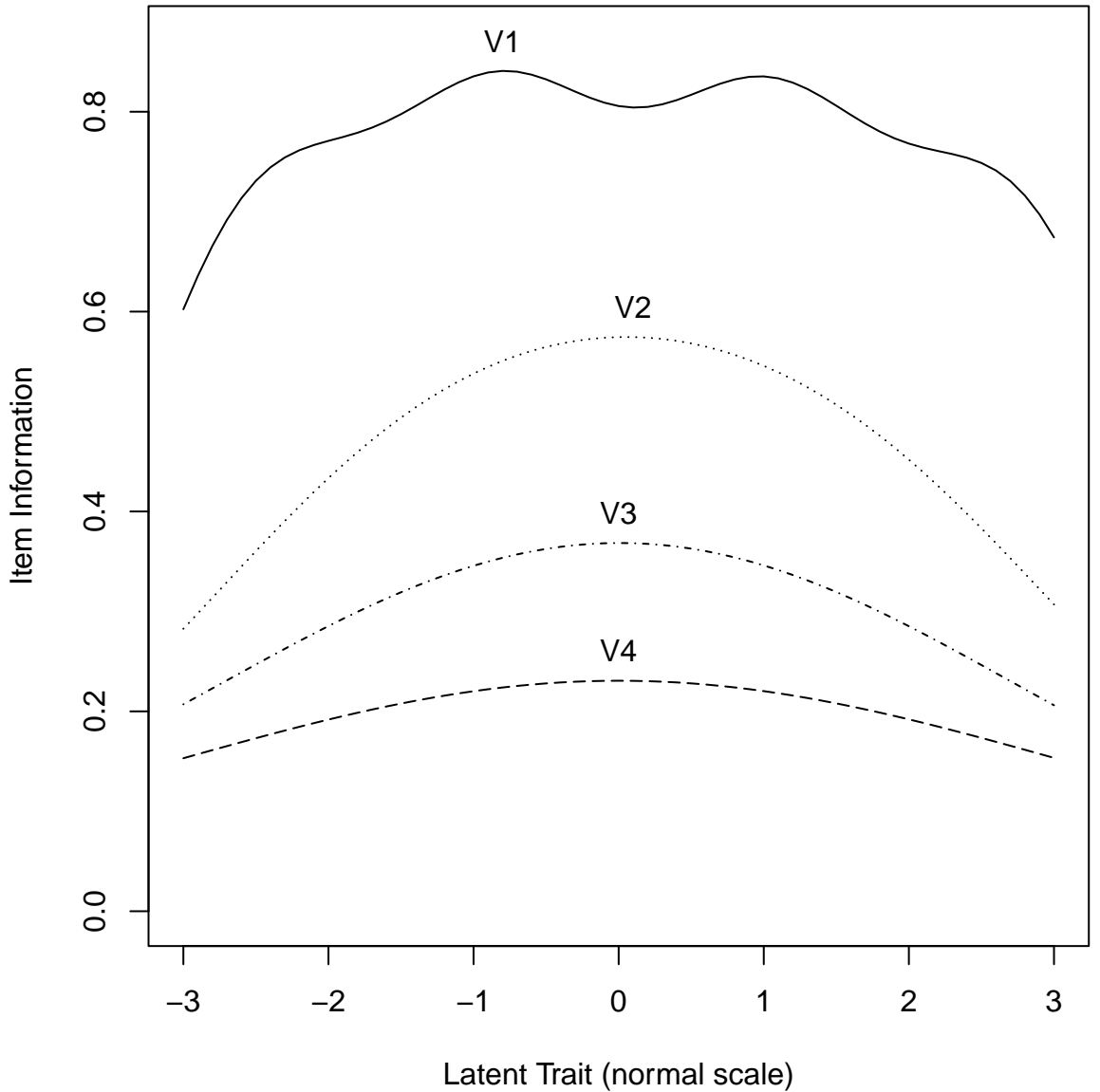

help("sim.congeneric")

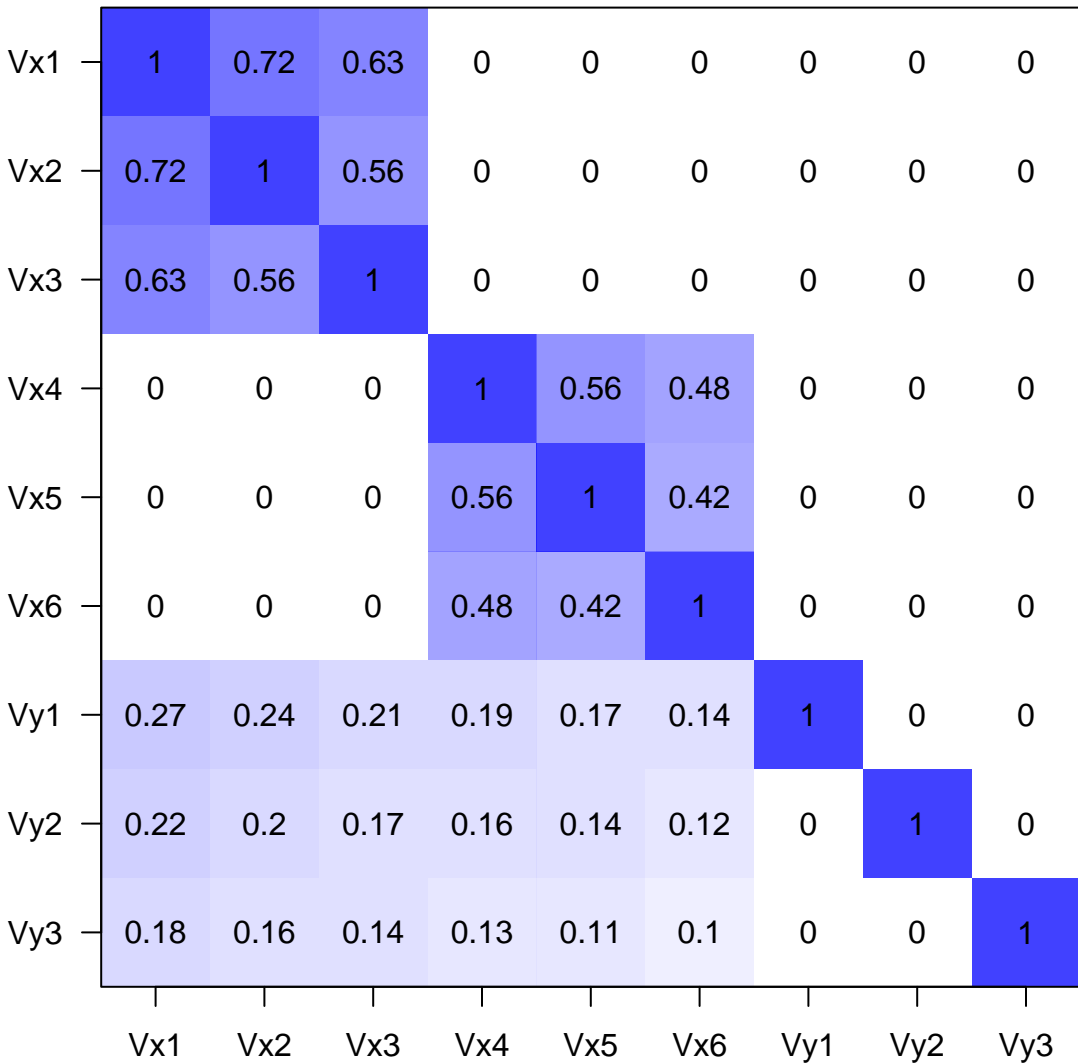

help("sim.irls")

A simplex structure

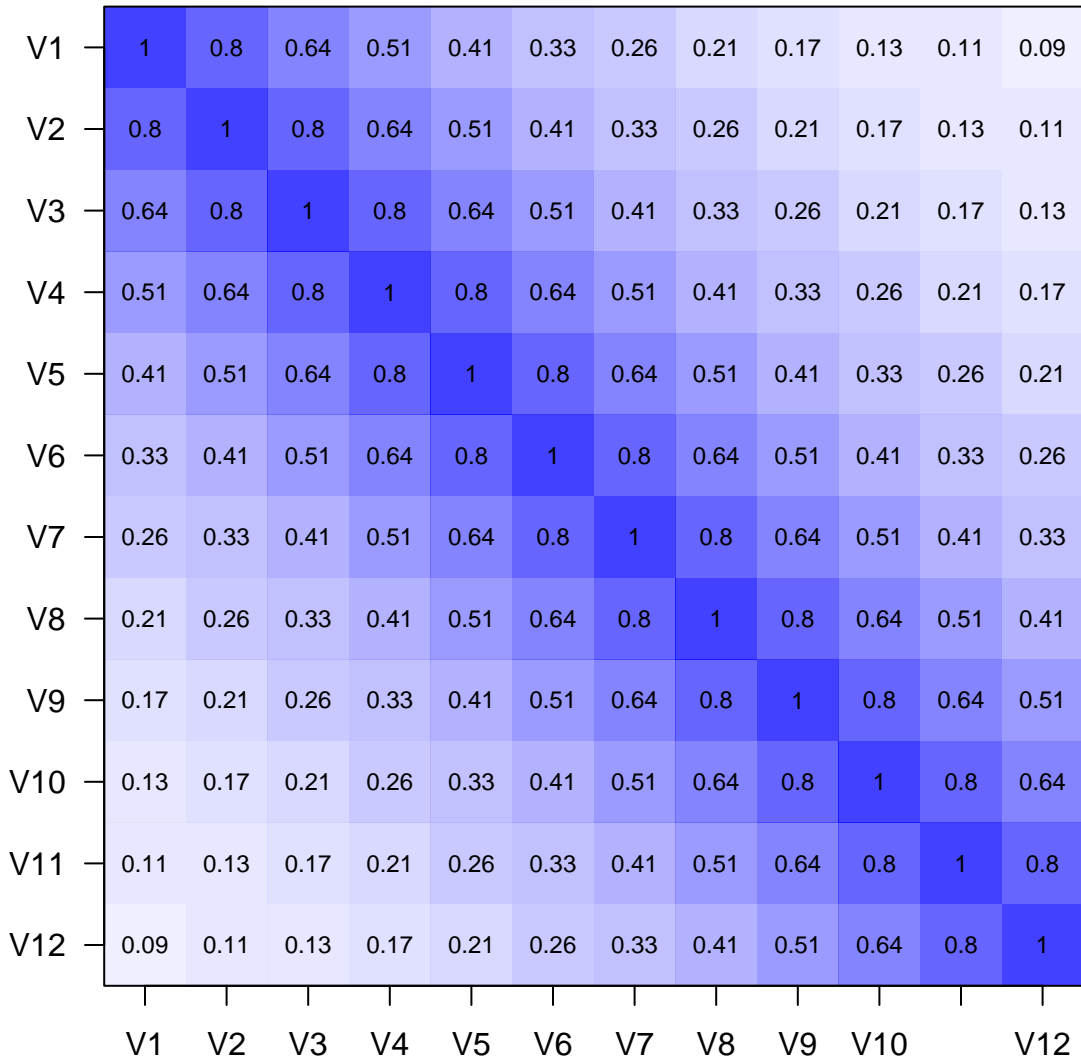

help("sim.irc")

State Trait Auto Regressive Simplex

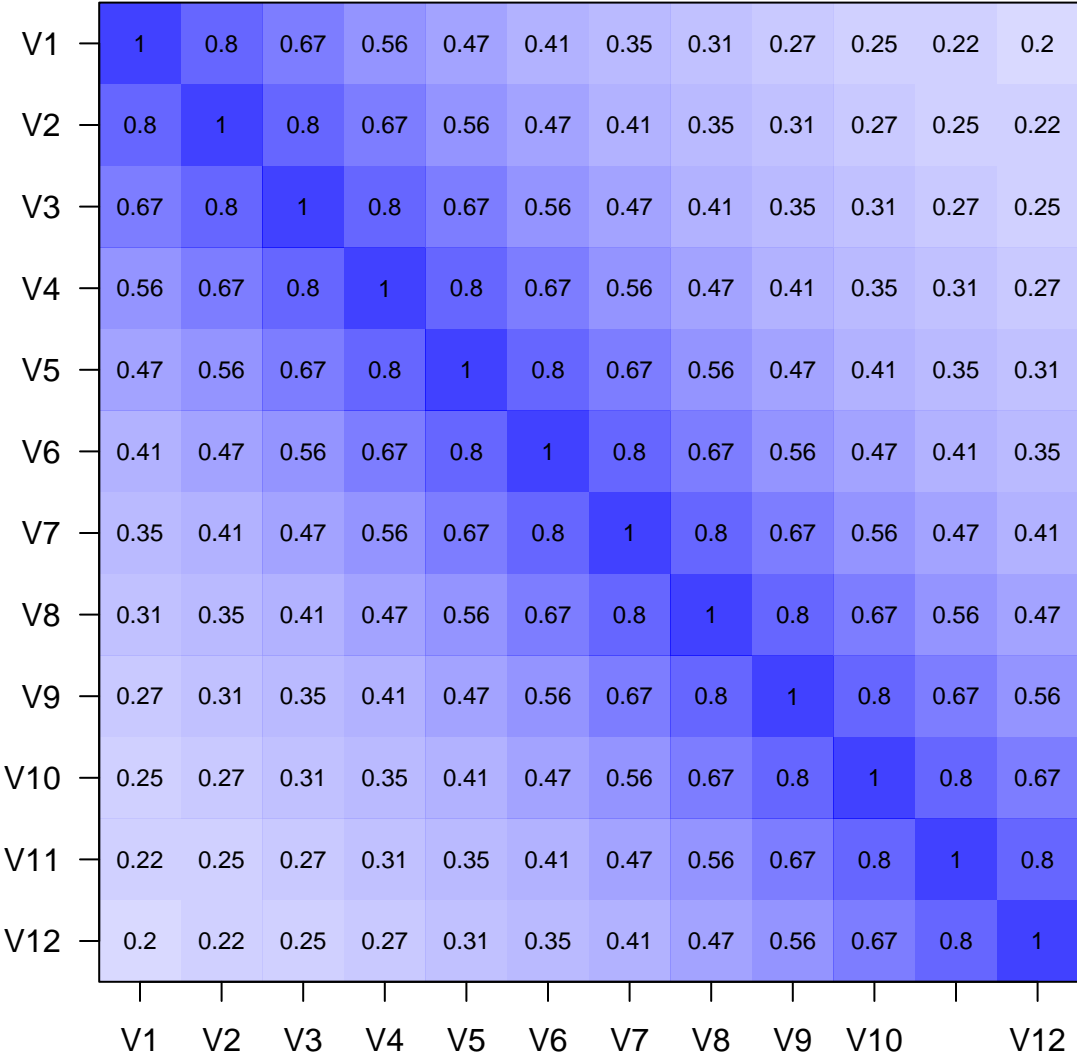

help("sim.irls")

Circumplex Structure

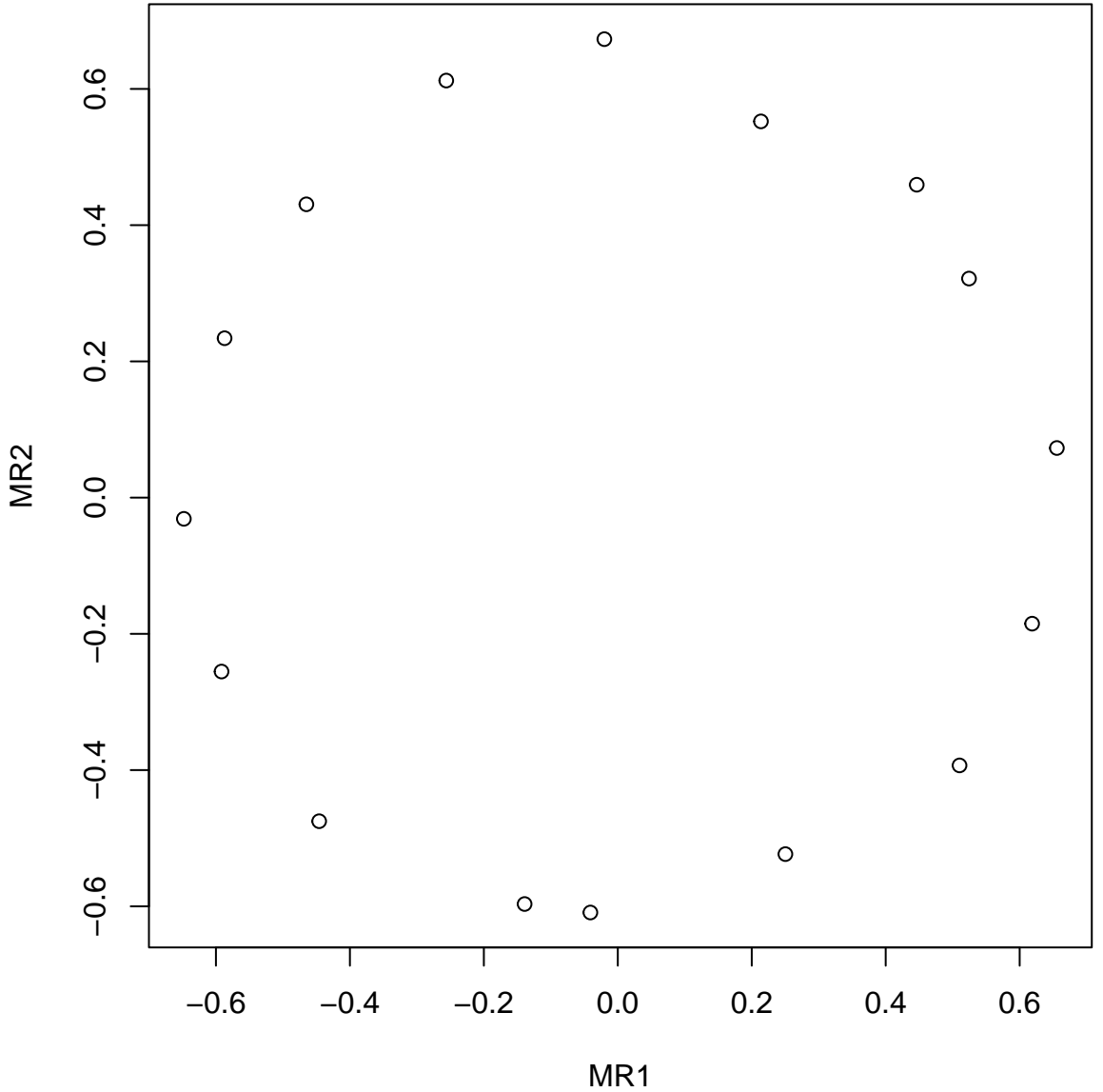

help("sim.item")

Simple Structure

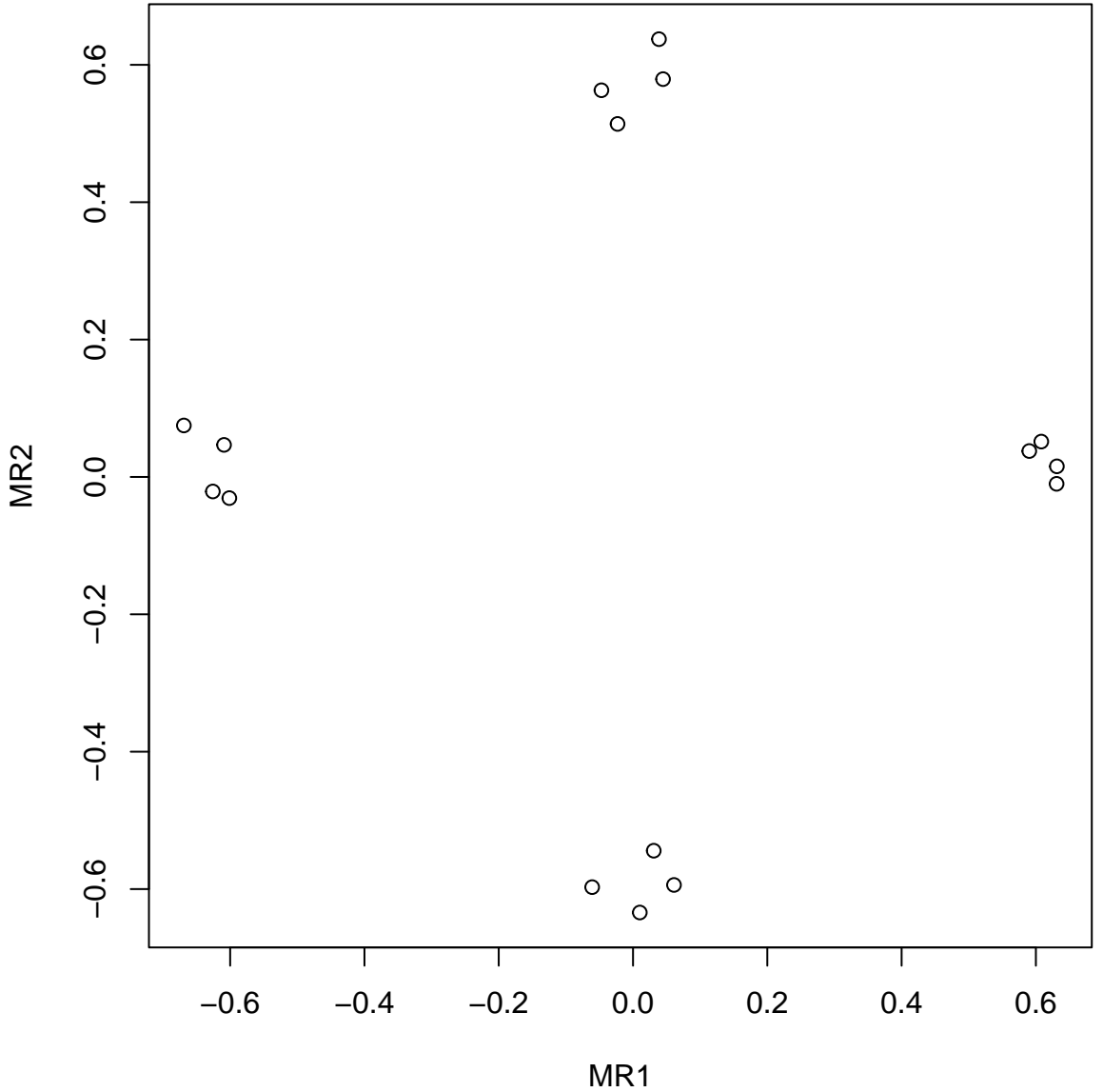

help("sim.item")

Cluster plot

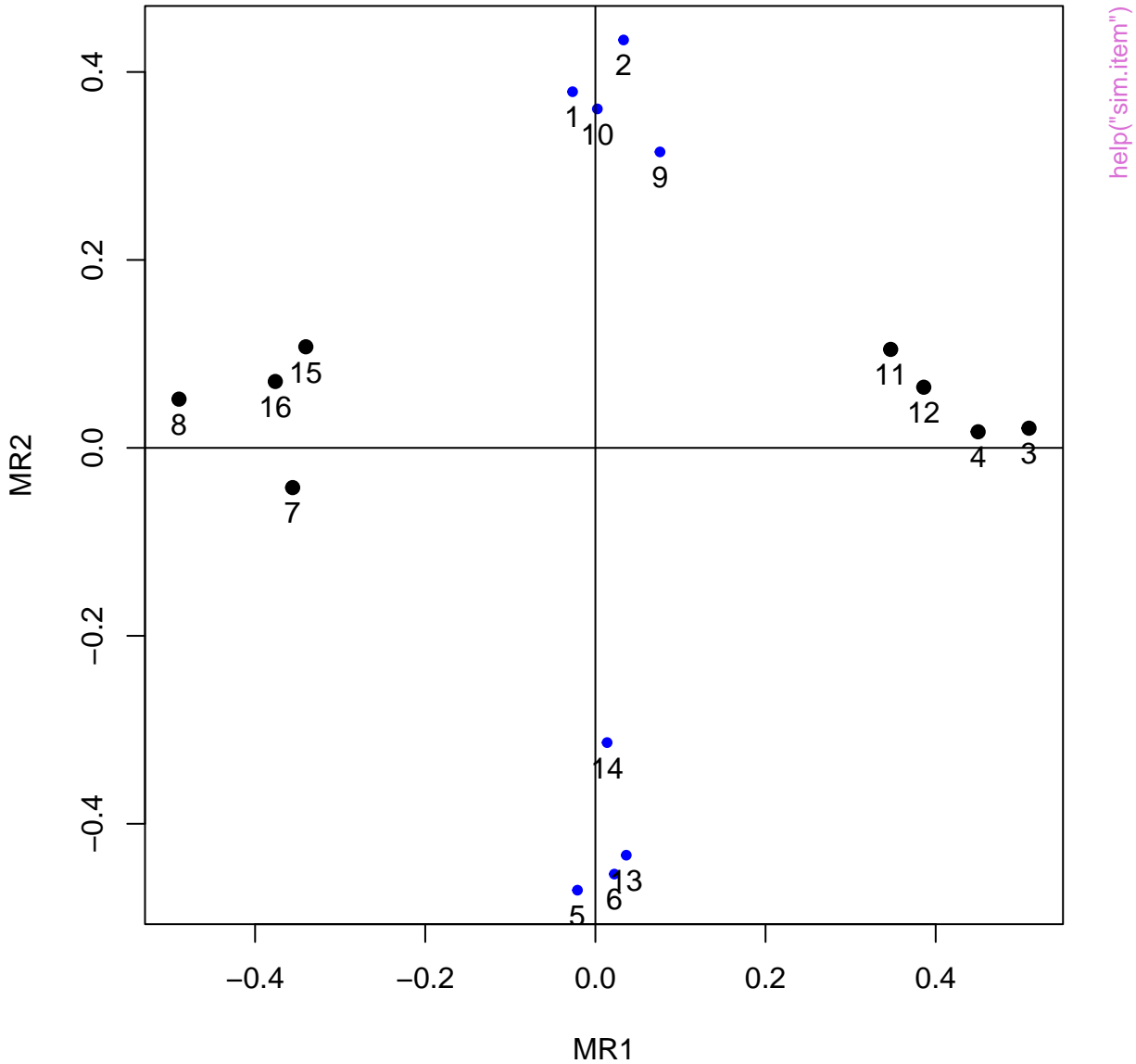

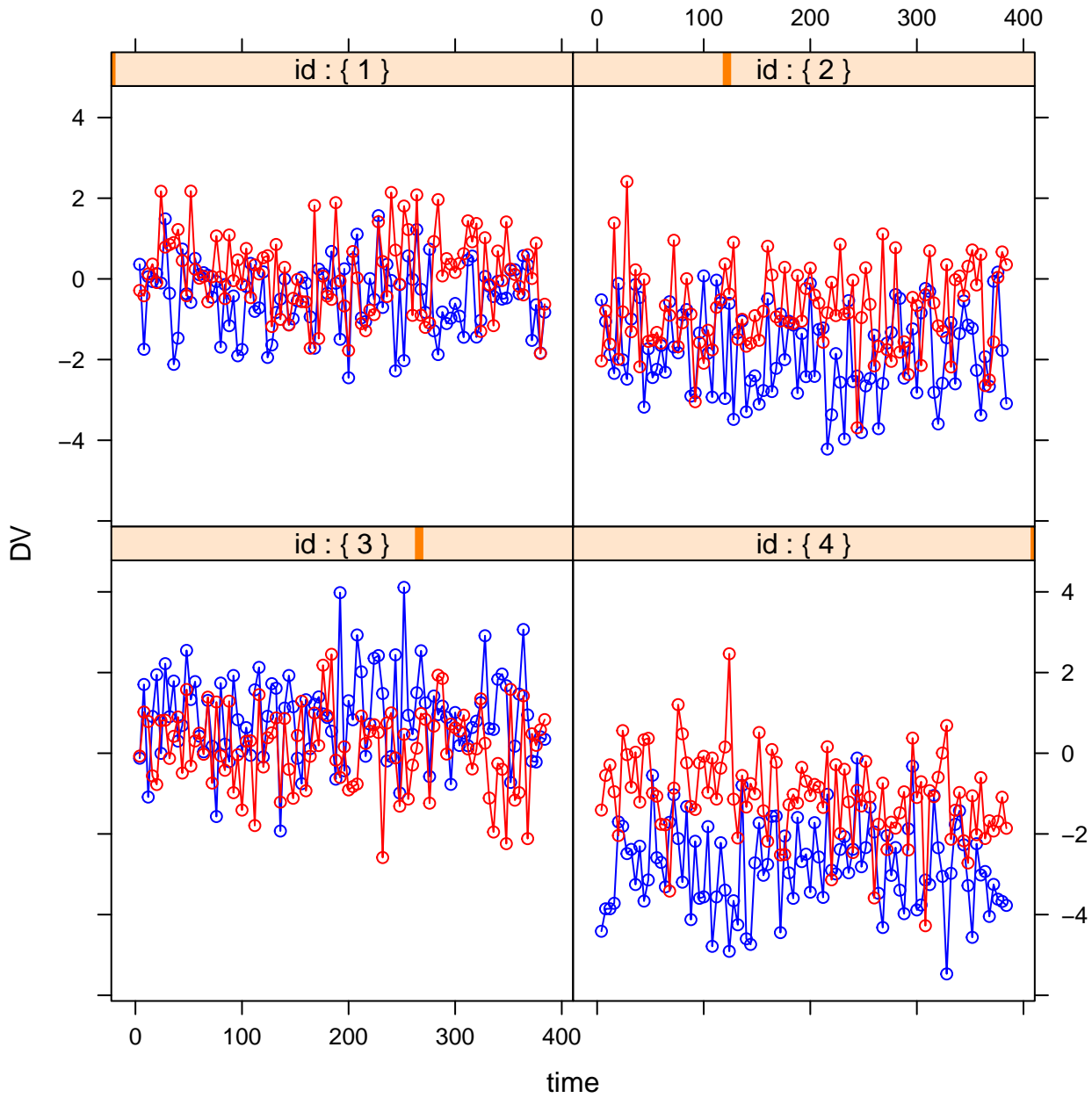

help("sim.multilevel")

4 tests of Circumplex Structure

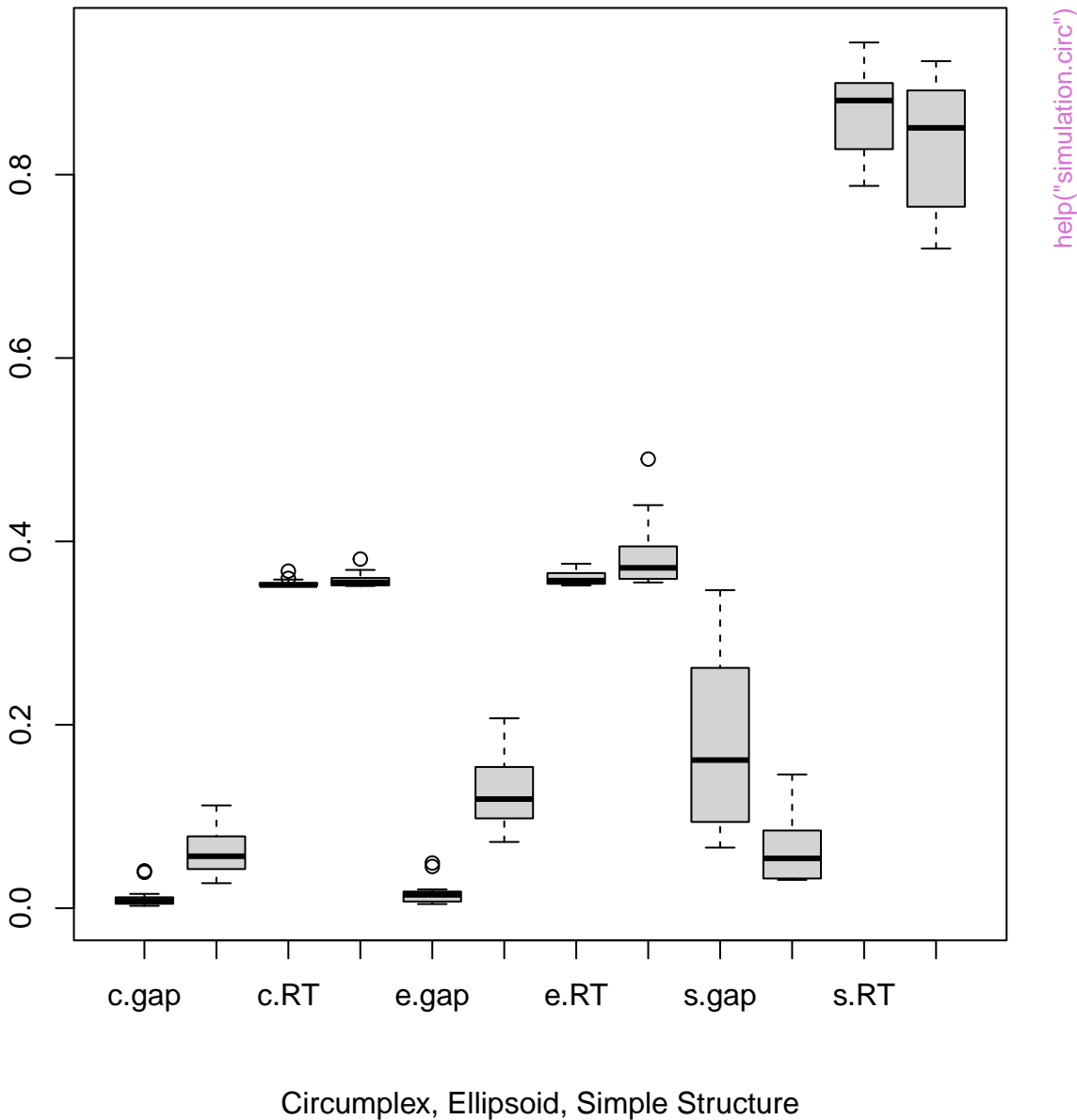

Circumplex Tests for Circumplex, Ellipsoid, and Simple Structure

Gap x Rotation

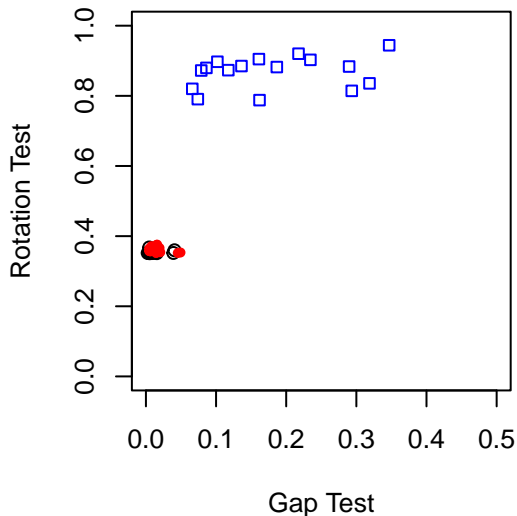

Gap x Fisher

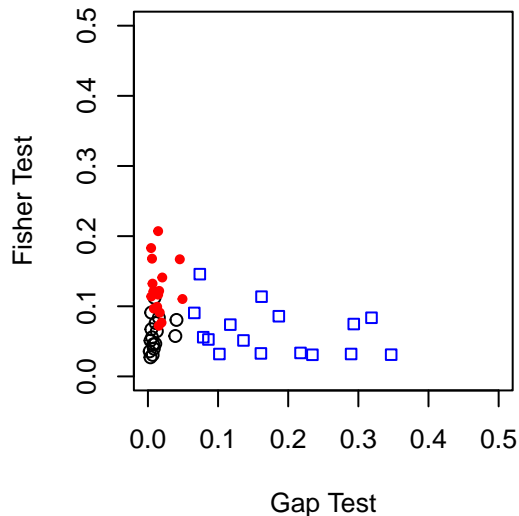

help("simulation.circ")

Fisher x Rotation

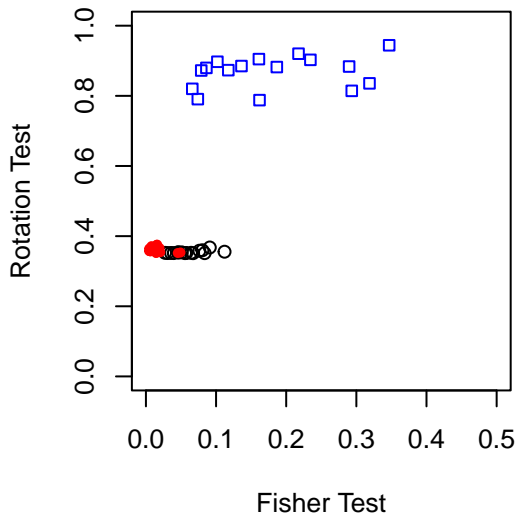

Box Plot of all tests

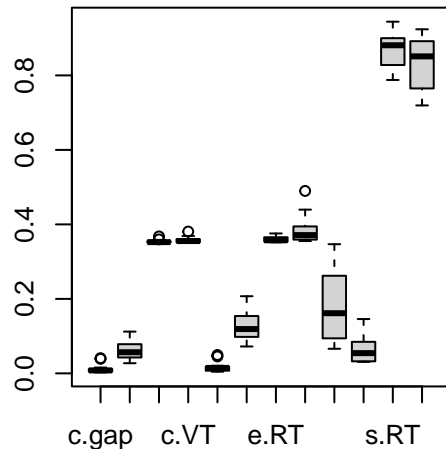

Normal Q-Q Plot

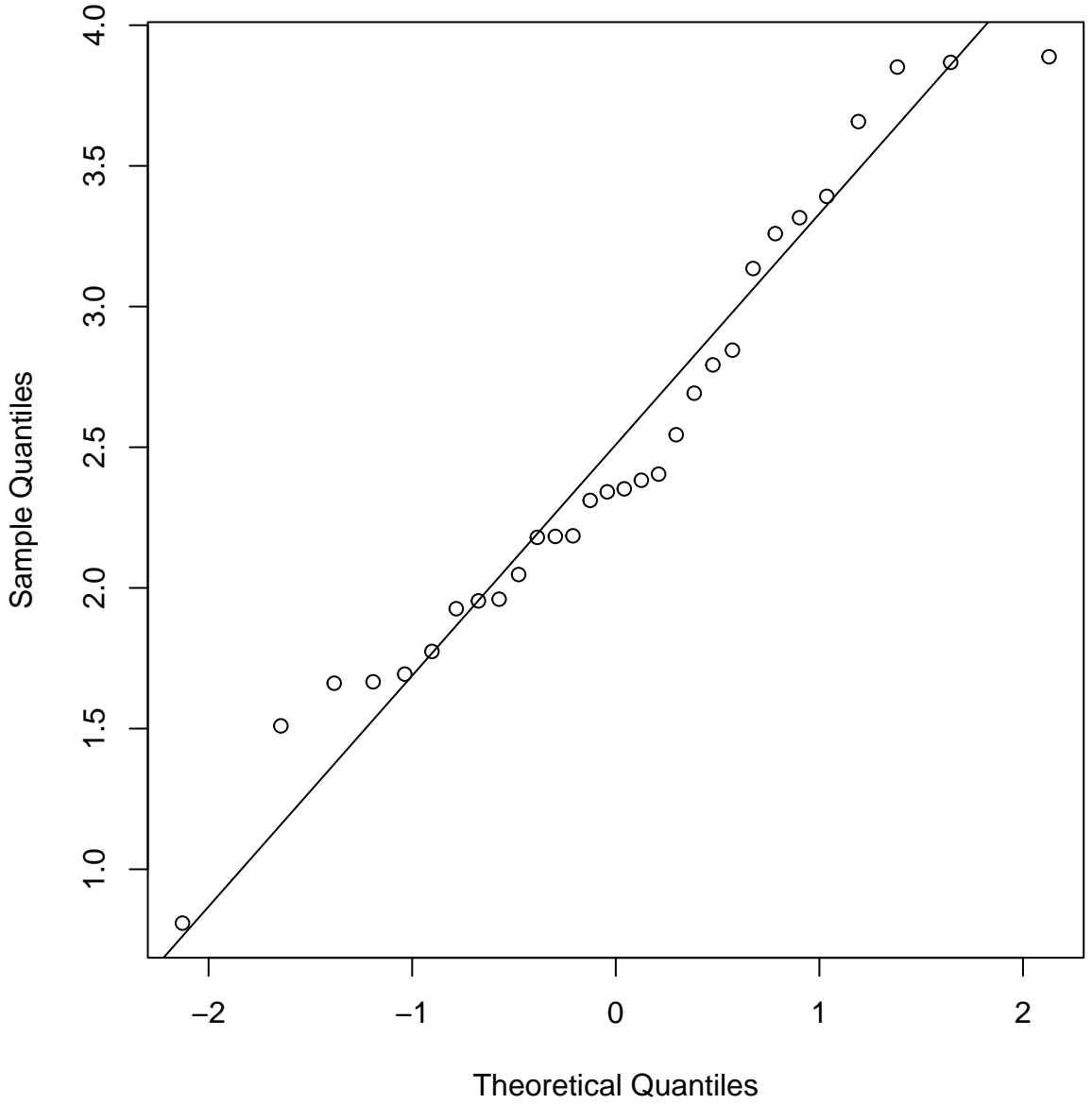

help("skew")

Normal Q-Q Plot

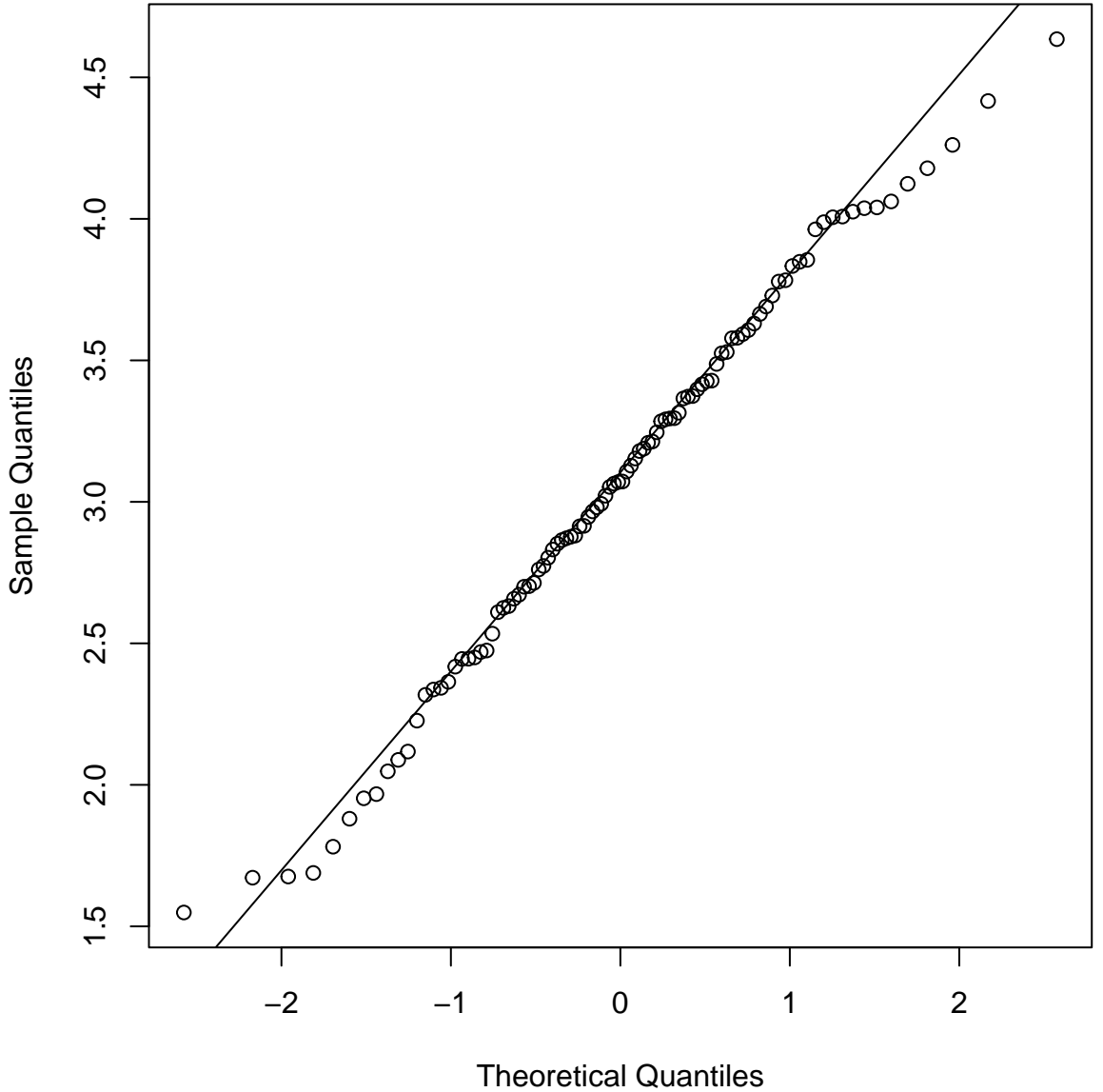

[help\("skew"\)](#)

Sentences



Sentences



help("spider")

Sentences

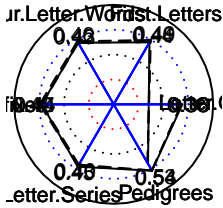

gender

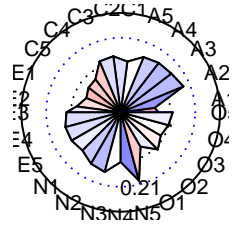

education

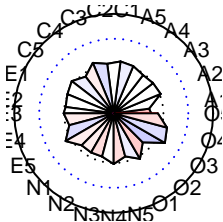

age

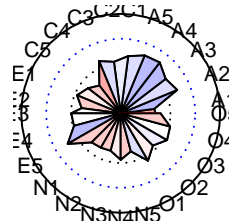

Data from Lippa (2001)

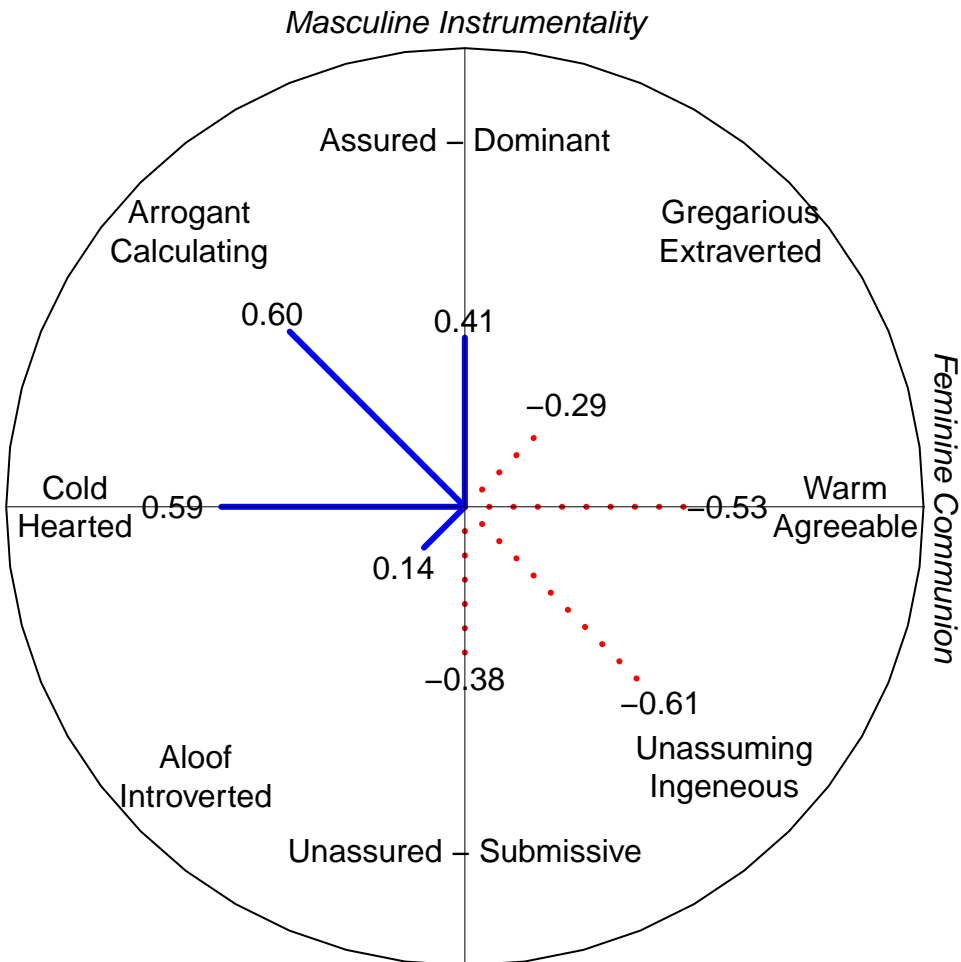

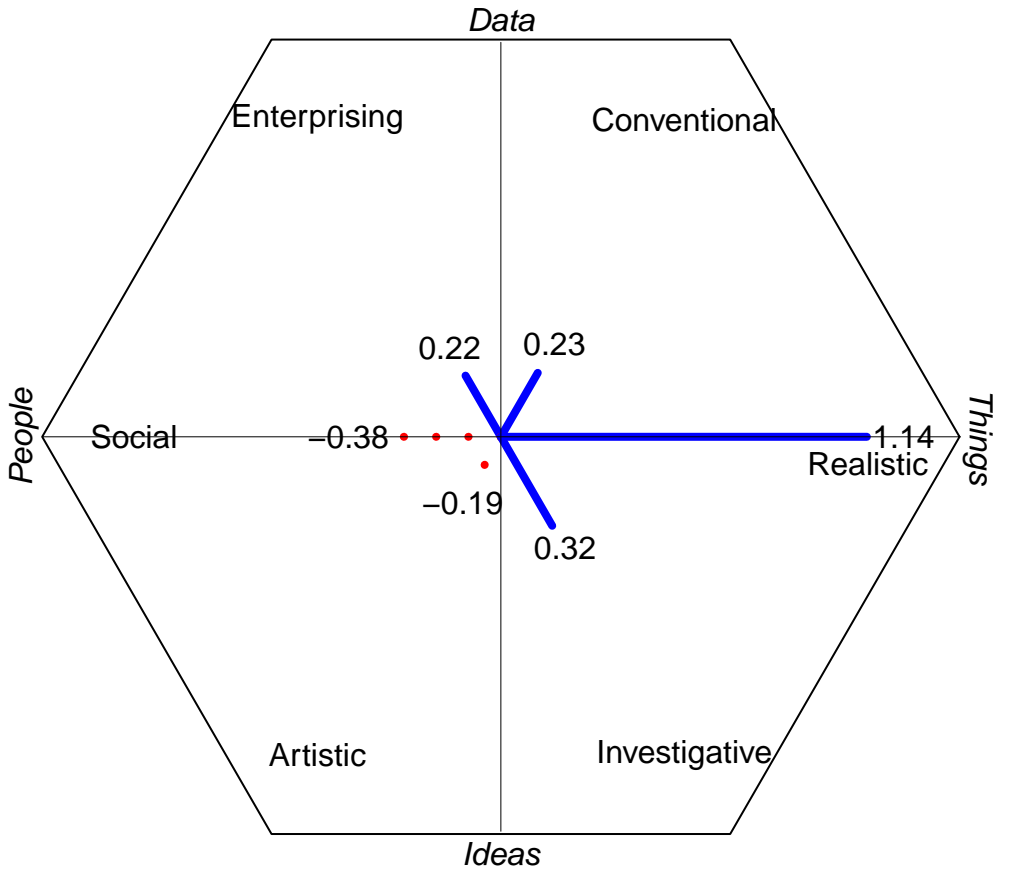

A measurement model for x

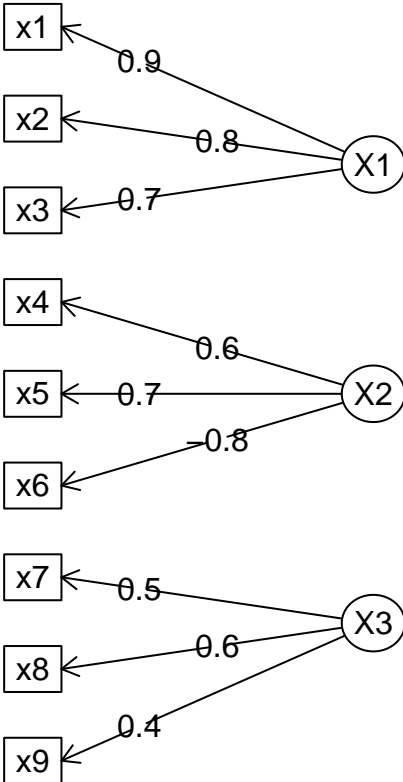

A measurement model for x

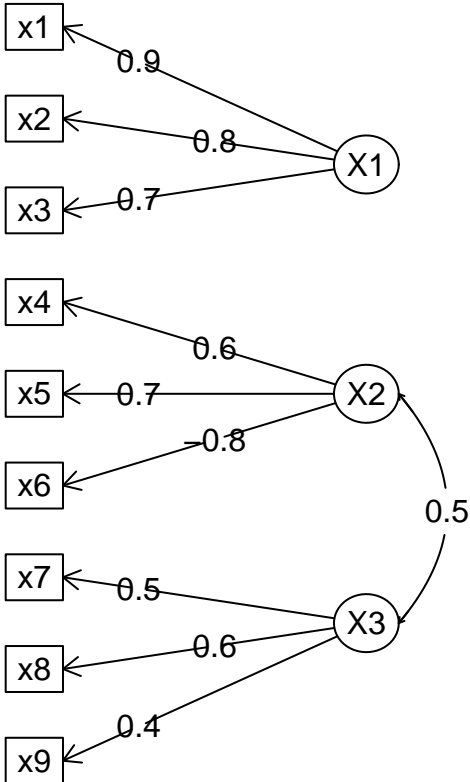

A measurement model for y

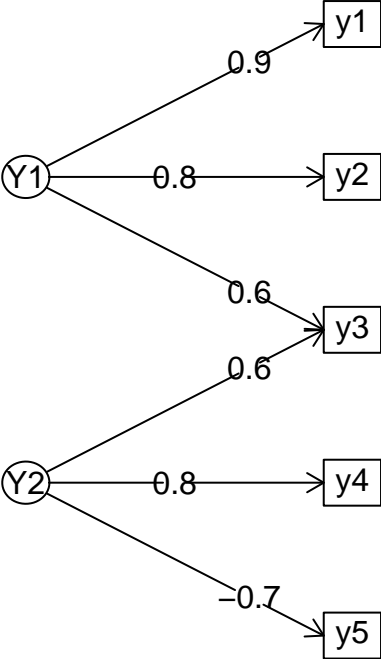

`help("structure.diagram")`

A structural path diagram

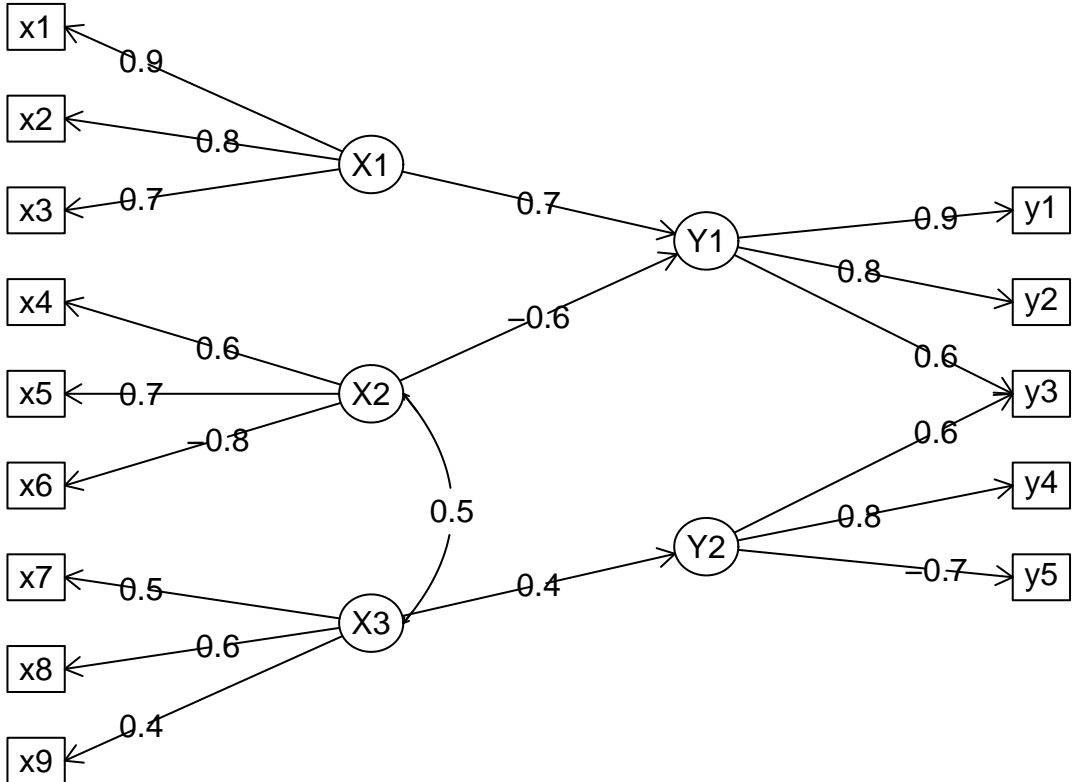

A structural path diagram

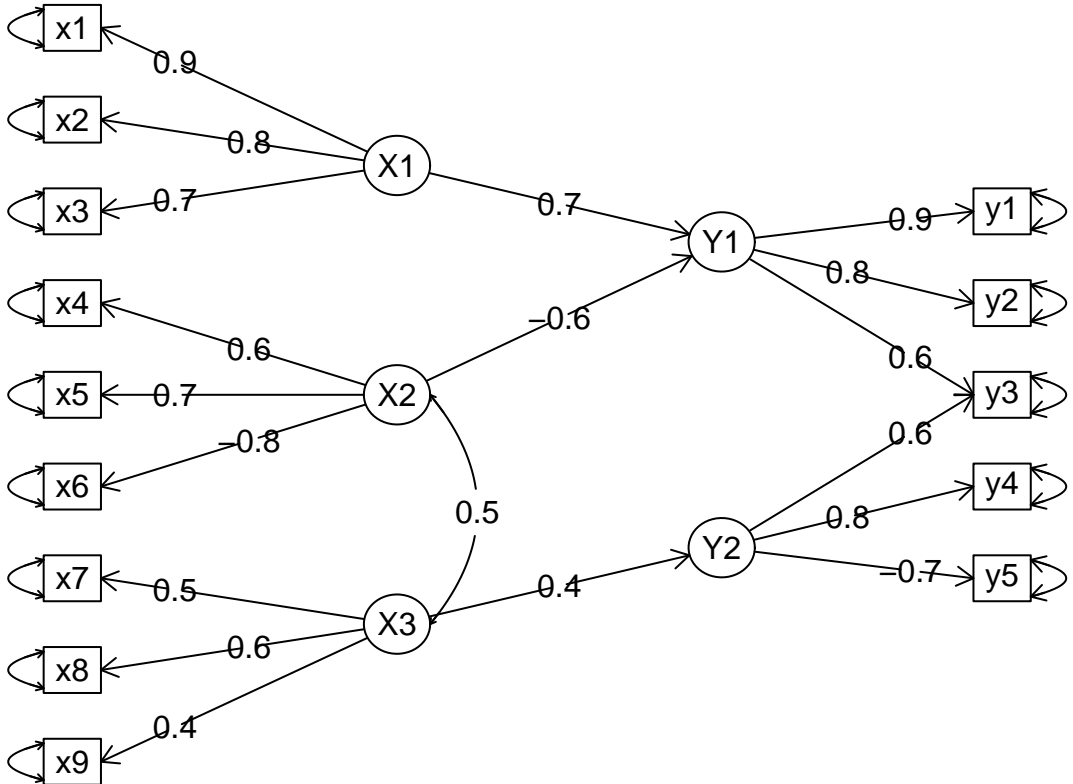

A mimic diagram

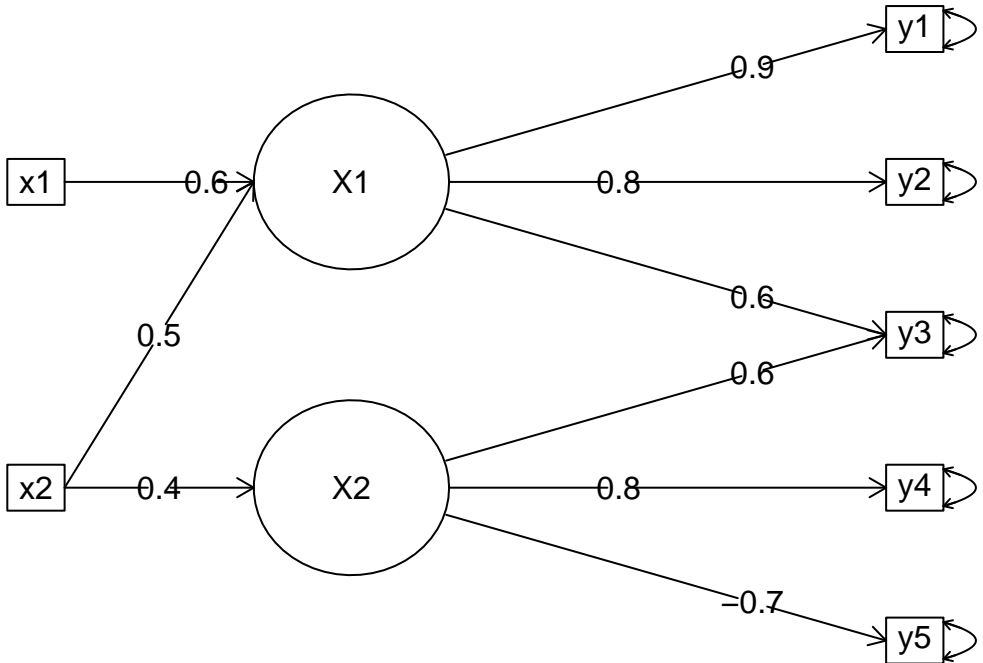

Structural model

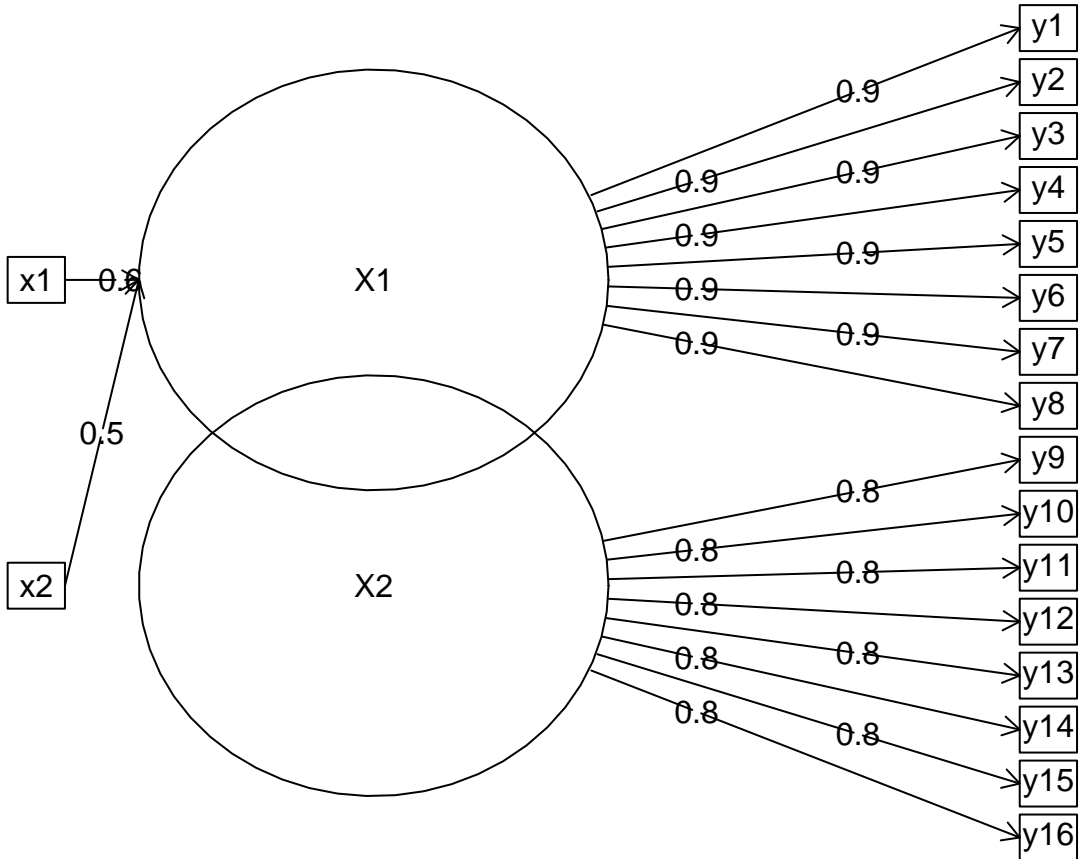

A symbolic model

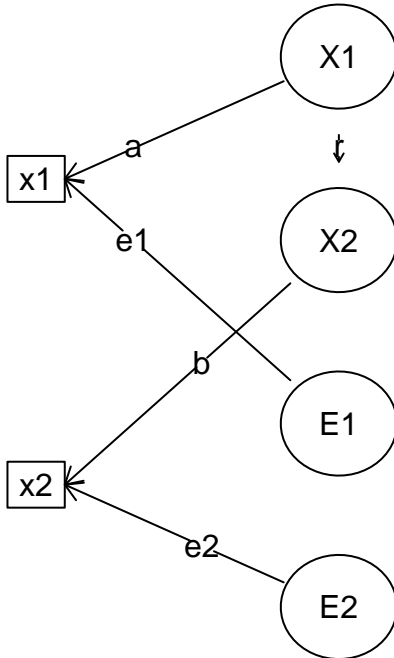

an alternative representation

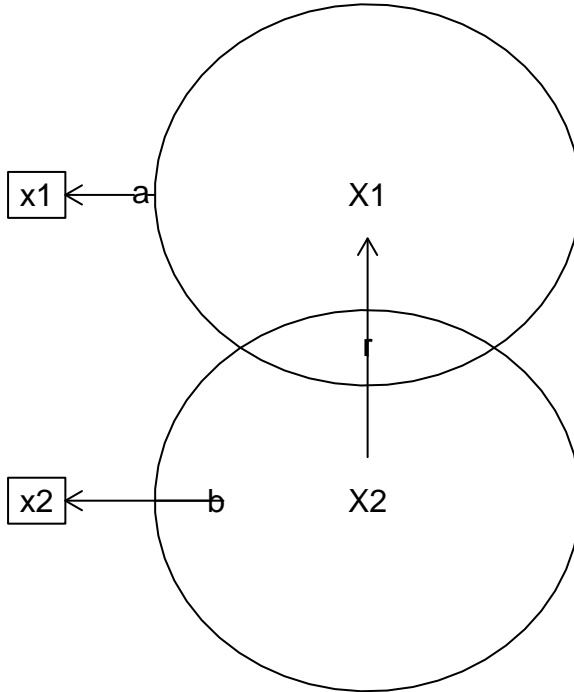

Structural model

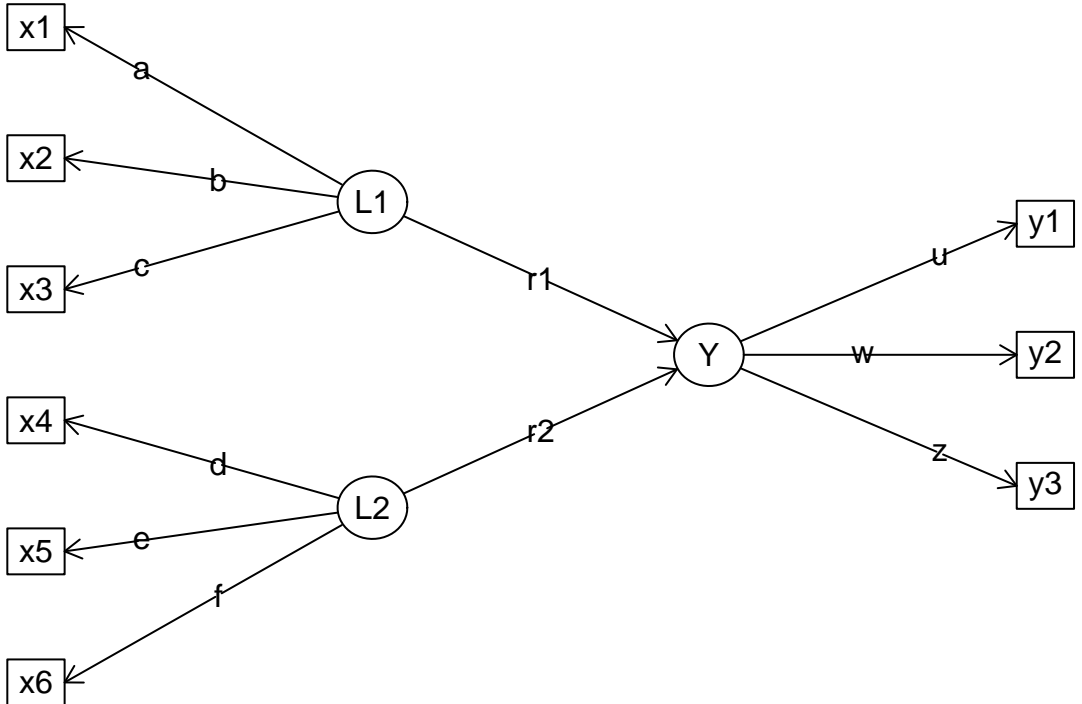

Regression model

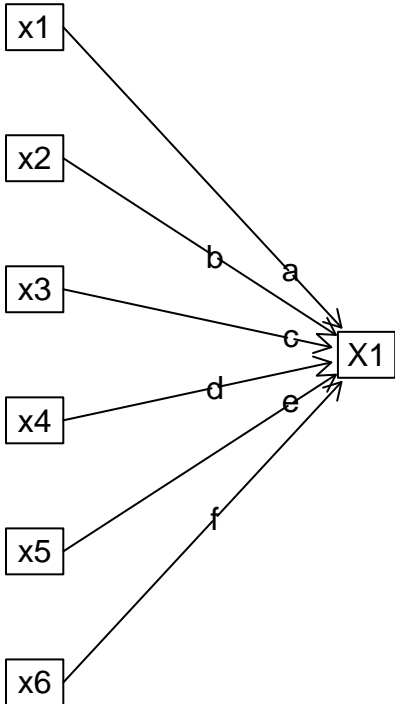

Regression model

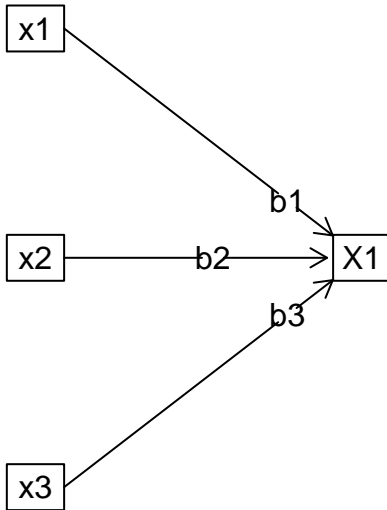

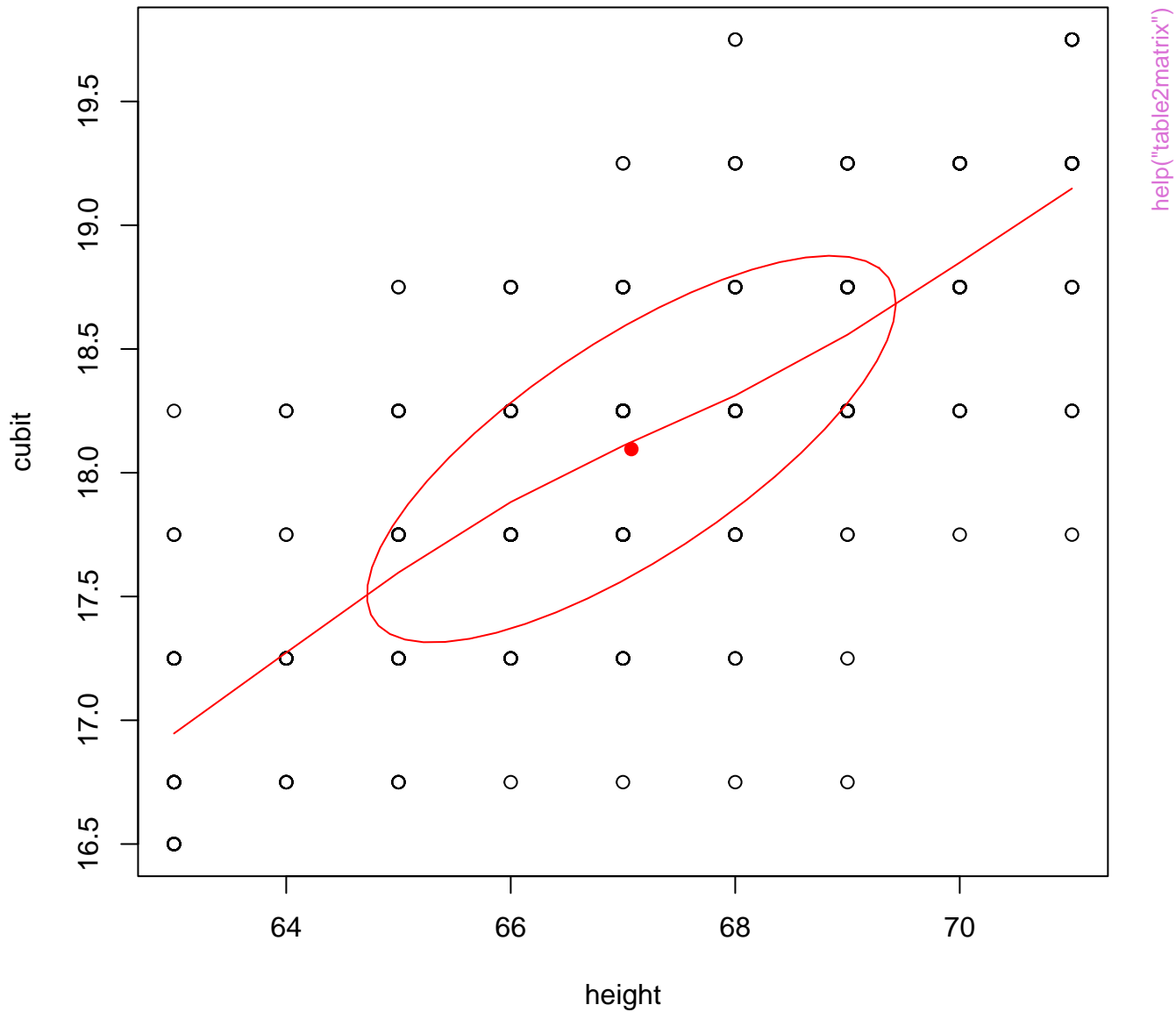

Mediation

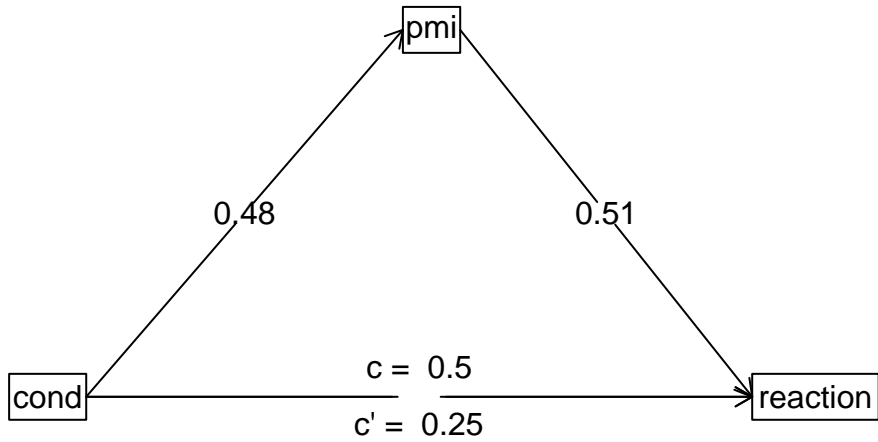

$r = 0.9$ rpb = 0.71 rbis = 0.89

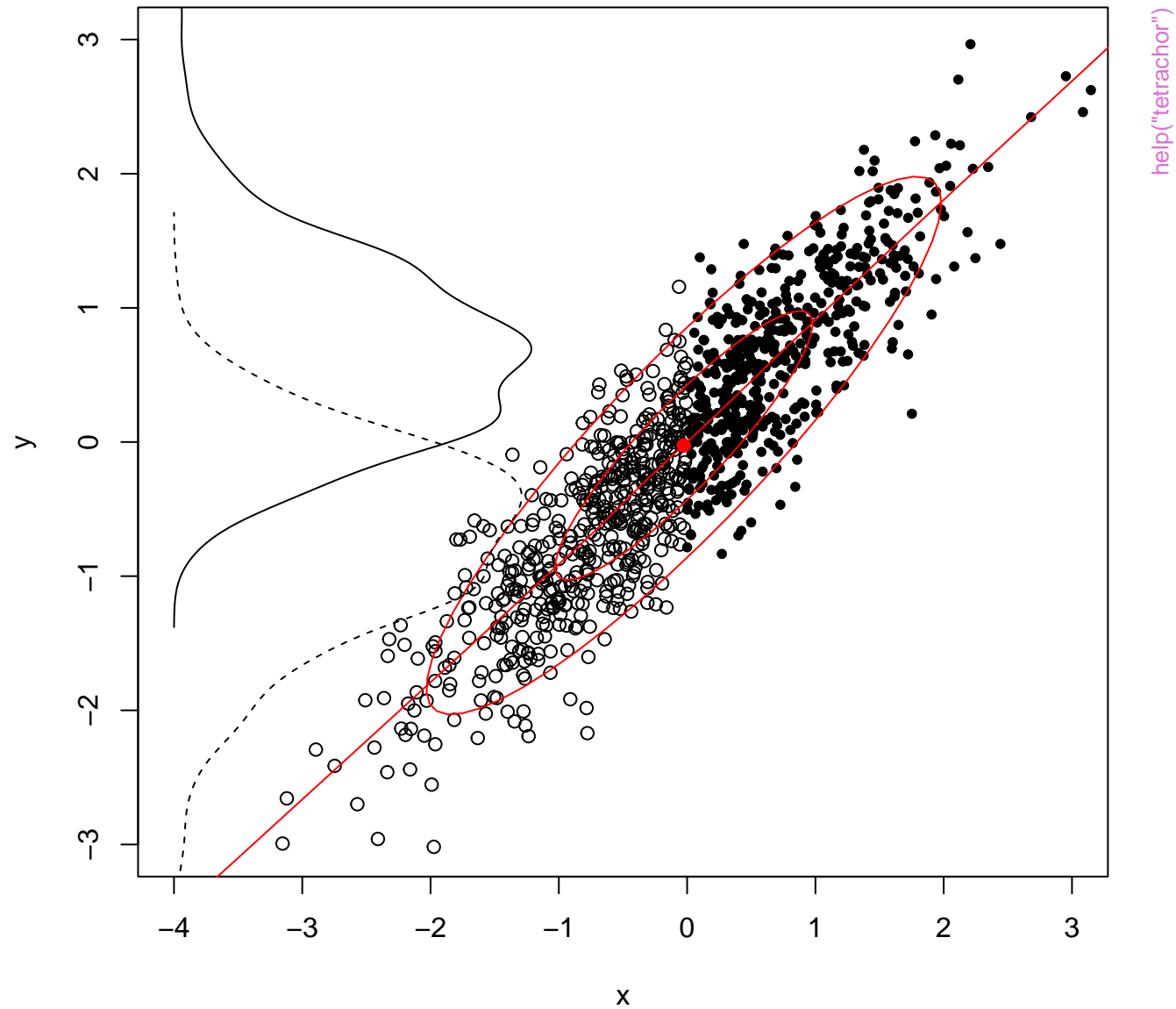

$r = 0.6$ rpb = 0.48 rbis = 0.6

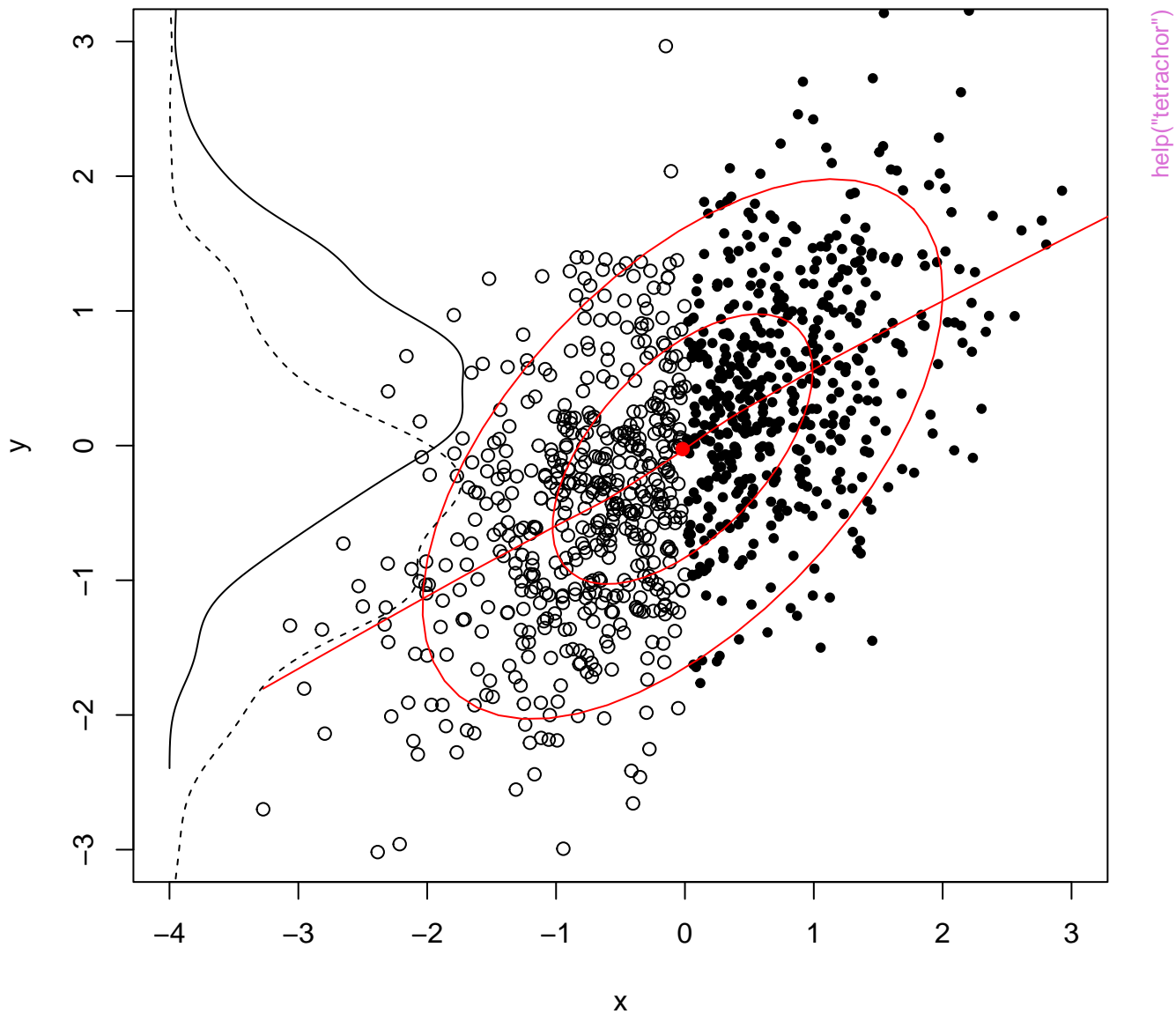

$r = 0.3 \text{ rpb} = 0.23 \text{ rbis} = 0.28$

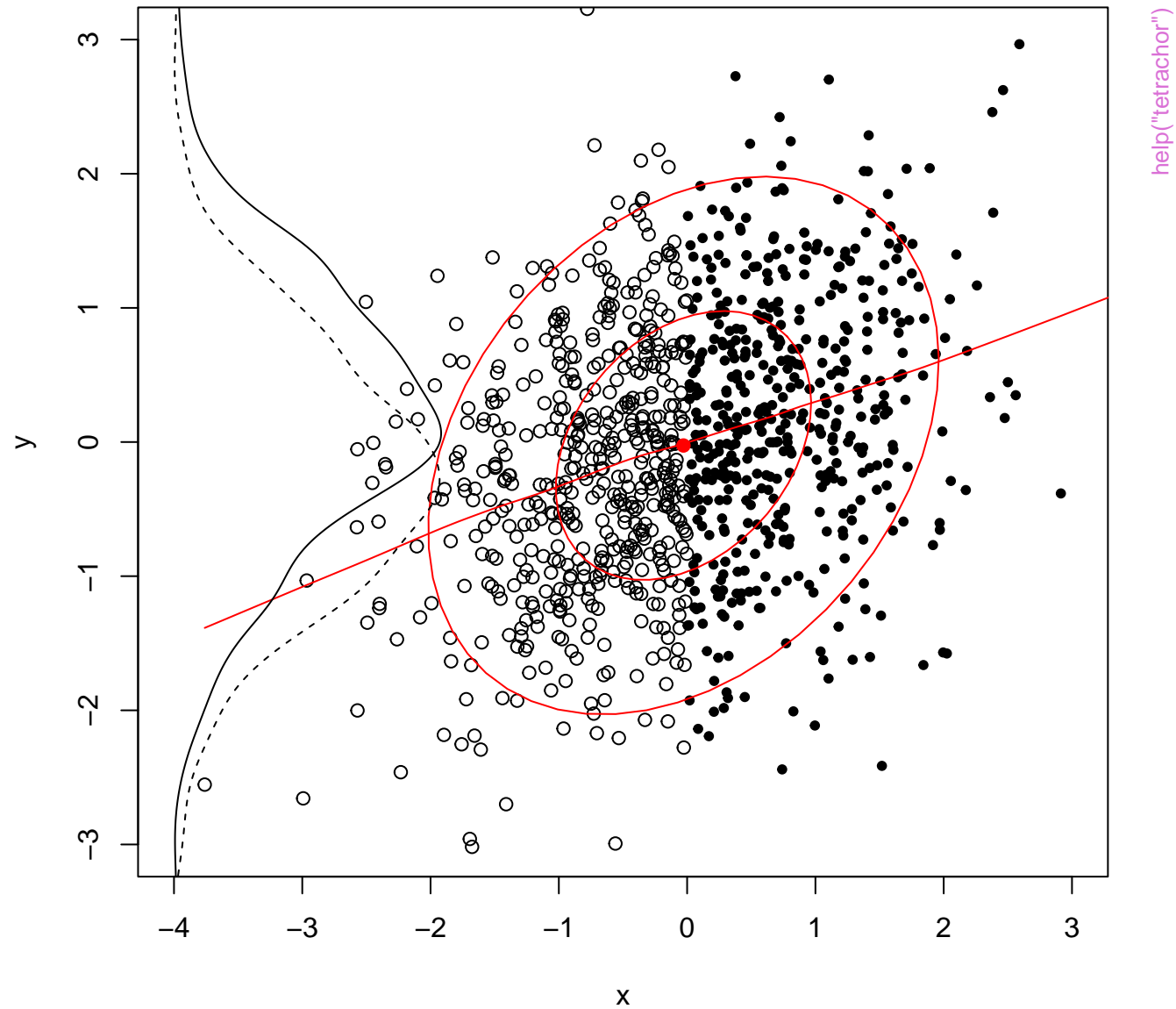

$r = 0 \text{ rpb} = 0.02 \text{ rbis} = 0.02$

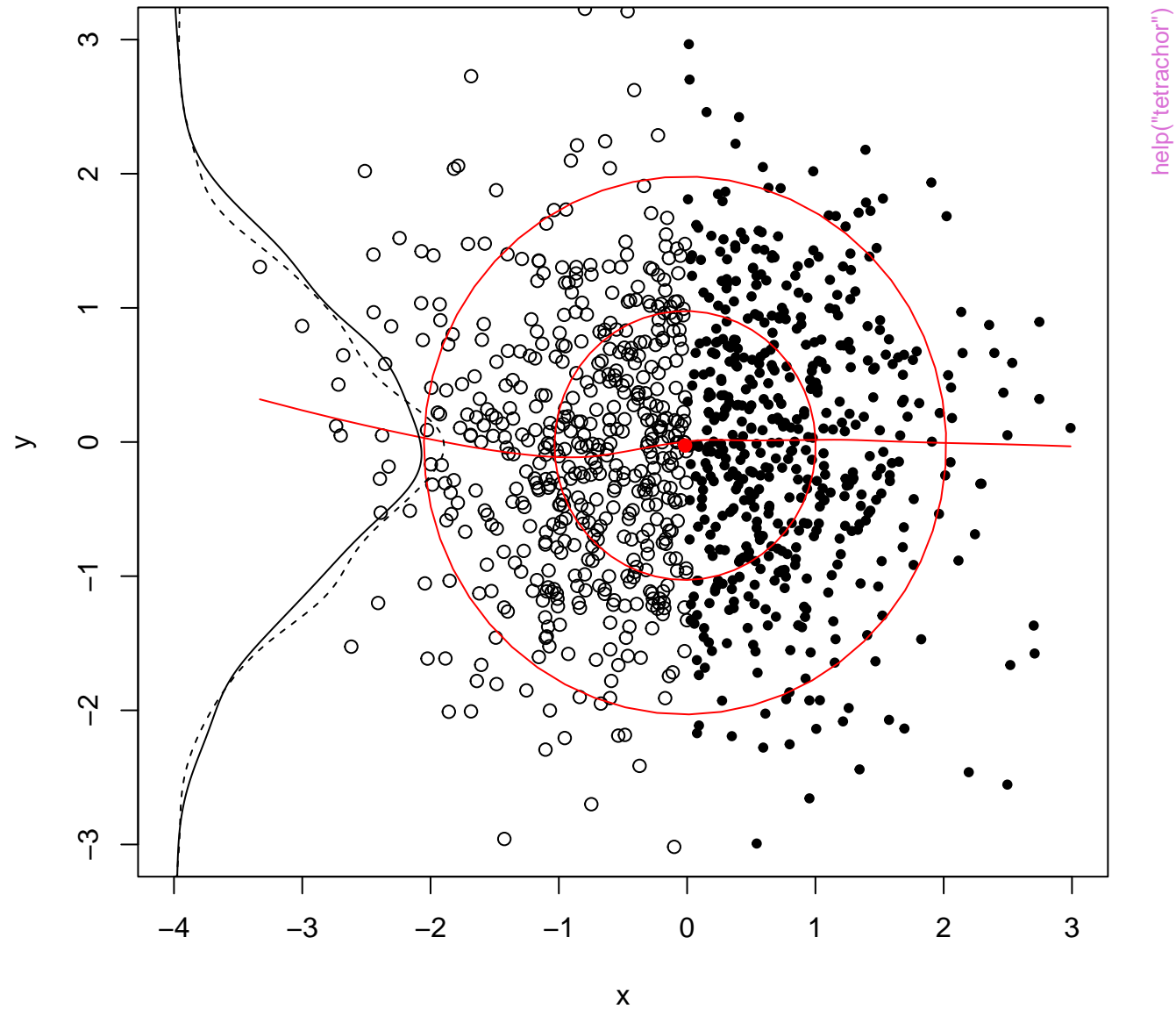

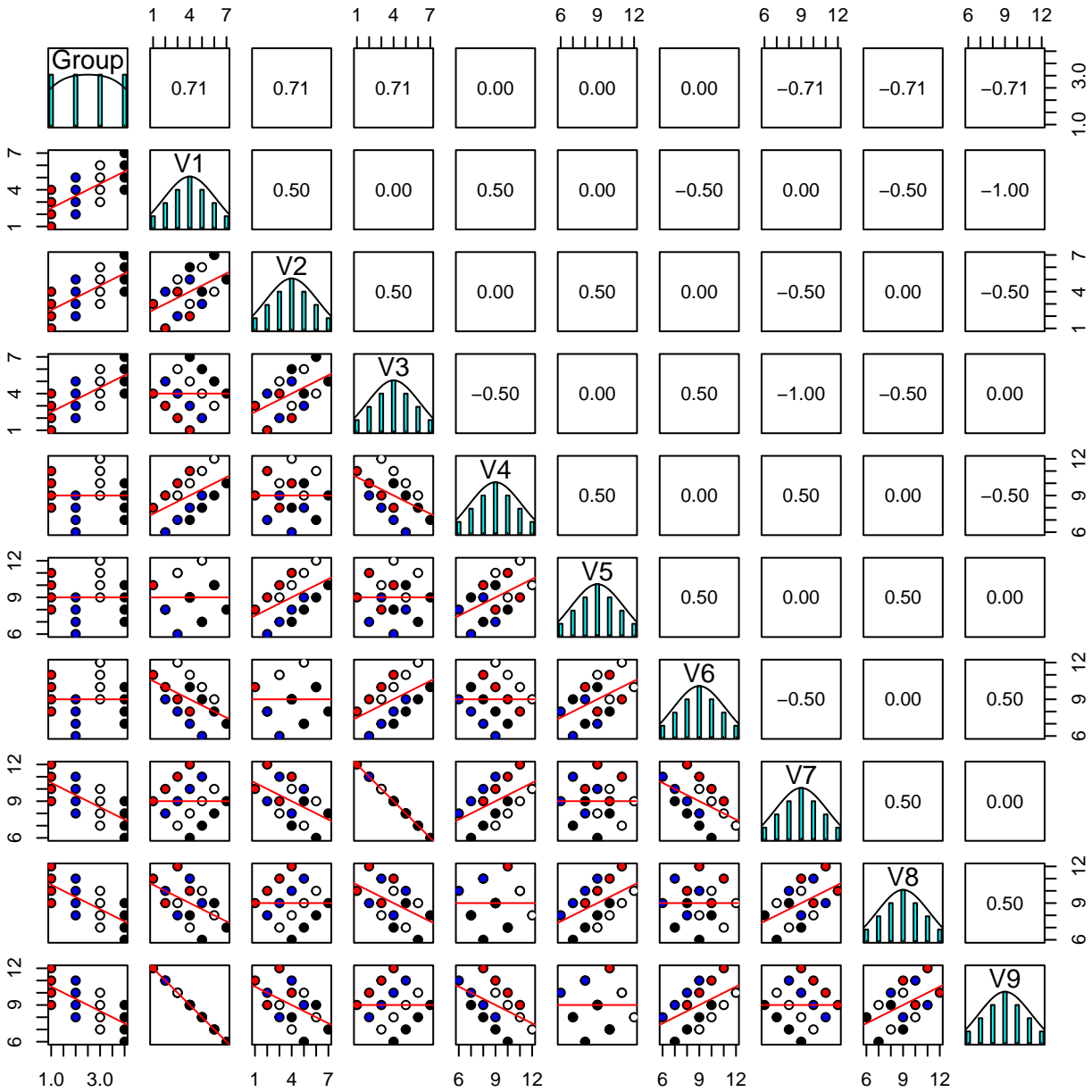

help("withinBetween")